

**ATMOSPHERIC VENTED WATER HEATER****⚠ WARNING:**

Improper installation, adjustment, alteration, service, or maintenance can cause injury or property damage. Refer to this manual. For assistance or additional information, consult a qualified installer, service agency, or the gas utility.

**⚠ FOR YOUR SAFETY**

- Do not store or use gasoline or other flammable vapours and liquids in the vicinity of this or any other appliance.
- Installation and service must be performed by a qualified installer, service agency or the gas utility.

**⚠ WARNING:**

If the information in these instructions is not followed exactly, a fire or explosion may result causing property damage, personal injury or death.

**WHAT TO DO IF YOU SMELL GAS**

- Do not try to light any appliance.
- Do not touch any electrical switch; do not use any phone in your building.
- Immediately call your gas supplier from a neighbor's phone. Follow the gas supplier's instructions.
- If you cannot reach your gas supplier, call the fire department.



TABLE OF CONTENTS

<b>I) INTRODUCTION</b> .....	<b>3</b>	<b>IV) OPERATING INSTRUCTIONS</b> .....	<b>14</b>
User Responsibilities	3	Water Temperature Regulation	14
<b>II) SAFETY</b> .....	<b>3</b>	Temperature Adjustment	
For Installations in Canada	3	Lighting Instructions (White-Rodgers 37C)	16
For Installations in the United States	3	Lighting Instructions (Honeywell 24 Volt)	17
Safety Warning (Flammable Vapours)	4	<b>V) OPERATION</b> .....	<b>18</b>
Safety Warning (Scalding)	4	Burner Flames	18
Safety Warning (Carbon Monoxide)	4	Emergency Shut Down	18
Relief Valves (T&P)	4	Checking the Draft	18
Backflow Prevention	4	Operating Conditions	18
<b>III) INSTALLATION</b> .....	<b>5</b>	Condensation	
Unpacking the Water Heater	5	Water Heater Sounds	
Location Requirements	5	Safety Shut-off	
In Earthquake Zones		Anode/Water Odour	
Clearances and Accessibility	5	Water Heater Operation (24 Volt only)	19
Gas Supply	6	System Error Codes for 24 Volt Controls	
Gas Pressure		<b>VI) MAINTENANCE</b> .....	<b>21</b>
Gas line purging		Periodic Cleaning of the Wrap-around Filter	21
Gas Leak Testing		Draining and Flushing	21
Air Requirements	8	Periodic Inspection	21
Confined Space Air Requirements for Canadian		External Cleaning of the Flame-arrestor	21
Installations	8	Temperature and Pressure Relief Valve	22
Confined Space Air Requirements for U.S.		Resetting and Replacing the Safety (TCO)	
Installations	9	Switch (NG models)	22
Exhaust Venting	10	Replacing the Thermocouple (TCO)	
Vent Pipe System		Assembly (LP models)	22
Check for proper vent size		24 Volt Honeywell Control Service	23
Draffhood Installation		Electronic Control Module Replacement	
Water Supply	10	Valve Module Replacement	
Piping Installation		Temperature Sensor and Cable Replacement	
Union Connections		<b>VII) COMBO HEATING</b> .....	<b>25</b>
Mixing Valves	11	System Requirements	25
Closed System/Thermal Expansion		<b>VIII) TROUBLESHOOTING GUIDE</b> .....	<b>26</b>
Temperature and Pressure (T&P) Relief Valve	12	<b>IX) REPAIR PARTS ILLUSTRATION</b> .....	<b>28</b>
The Temperature And Pressure Relief Valve:		<b>LIMITED WARRANTY</b> .....	<b>31</b>
The Discharge Line:			
Electrical Supply	13		
24 Volt Control precautions			
Installations Check	14		

RETAIN THESE INSTRUCTIONS IN A SAFE LOCATION FOR FUTURE REFERENCE

## Your safety and the safety of others is very important.

We have provided many important safety messages in this manual and on your appliance. Always read and obey all safety messages.



This is the safety alert symbol.

This symbol alerts you to potential hazards that can kill or hurt you and others. All safety messages will follow the safety alert symbol and either the word "DANGER" or "WARNING".



**DANGER**

You can be killed or seriously injured if you don't immediately follow instructions.



**WARNING**

You can be killed or seriously injured if you don't follow instructions.

All safety messages will tell you what the potential hazard is, tell you how to reduce the chance of injury, and tell you what can happen if the instructions are not followed.

## I) INTRODUCTION

We thank you for choosing a **Flammable Vapour Resistant Water Heater**. Your satisfaction with this product is very important to us. This gas-fired water heater has been developed to produce domestic hot water and may also be used in combination with space heating applications but not space heating only. The Flame Guard™ safety system is designed to reduce the risk of flammable vapour related fires by trapping the burning vapours within the water heater combustion chamber using the special flame arrestor. The burning vapours literally "burn themselves out" without escaping back into the room.

### User Responsibilities

These instructions have been written for the proper installation, safe operation and maintenance of this water heater. It is your responsibility to ensure that your water heater is properly installed and cared for.

**FAILURE TO FOLLOW THE INSTRUCTIONS IN THIS MANUAL MAY RESULT IN SERIOUS BODILY INJURY AND/OR PROPERTY DAMAGE. THOROUGHLY READ ALL INSTRUCTIONS BEFORE YOU ATTEMPT TO INSTALL, OPERATE OR MAINTAIN THIS HEATER.**

Installation and service requires trade knowledge in the area of plumbing, electricity, venting, air supply and gas supply. If you lack these skills or do not understand these instructions, enlist the help of a qualified professional.

The manufacturer of this water heater cannot be held liable for those damages caused by improper installation, sizing or failure to comply with these instructions.

**Protect your warranty:** Regularly maintain your water heater and venting system as detailed in the "Maintenance" section of this manual.



### WARNING

**Service to the Flame Guard™ safety system should only be performed by a qualified service technician.**

## II) SAFETY

This water heater is design-certified by CSA International as a Category I, non-direct vented water heater which takes its combustion air either from the installation area or from air ducted to the unit from the outside.

In addition to the installation instructions found in this manual, the heater shall be installed according to all local and provincial or state codes and with the latest edition of the following specifications.

### For Installations in Canada

"Natural Gas and Propane Installation Code" CSA-B149.1 and "Canadian Electrical Code (CAN/CSA C22.1), Part I" available from:

Canadian Standards Association,  
5060 Spectrum Way,  
Mississauga, Ontario, Canada  
L4W 5N6

### For Installations in the United States

"National Fuel Gas Code" ANSI Z223.1 (NFPA 54) and "National Electrical Code" (NFPA 70)" available from:

American National Standards Institute,  
25 West 43rd Street,  
New York, NY 10036

**Massachusetts code** requires this water heater to be installed in accordance with Massachusetts Plumbing and Fuel Gas Code 248 CMR Section 2.00 and 5.00.

Check your phone listings for the local authorities having jurisdiction over your installation.

**Important:** All supply equipment, installation, approvals, permits, inspections, etc. are the responsibility of the owner of this water heater. Consult your local authorities for regulations specific to your area.

## Safety Warning (Flammable Vapours)



There is a risk in using fuel-burning appliances such as water heaters. Areas that may not be suitable for water heater installation include those where flammable liquids, gasoline, solvents, adhesives, etc., or engine-driven equipment or vehicles are stored, operated or repaired. Due to the nature of air movement, flammable vapours can be carried some distance from the point of storage. The gas-fired water heater igniter or main burner flame can ignite these vapours causing a flashback, fire or explosion which may result in serious personal injury or death, as well as severe property damage.

## Safety Warning (Scalding)

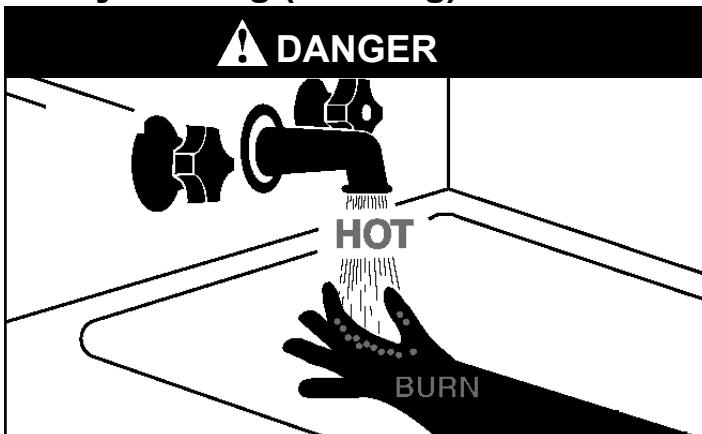

Hot water produced by this appliance can cause severe burns due to scalding. The hazard is increased for young children, the aged or the disabled where water temperatures exceed 52°C (125°F). Use tempering valves (see Figure 11), in the hot water system to reduce the risk of scalding at point-of-use such as lavatories, sinks and bathing facilities. Such precautions must be followed when this heater is operated in combination with dishwashing or space heating applications.

## Safety Warning (Carbon Monoxide)

As with all fuel burning equipment, this heater requires an adequate supply of air for combustion and ventilation. An insufficient air supply can result in poor combustion or the re-circulation of the exhaust flue gases. Such a condition can cause soot build-up or present a fire hazard, and may

result in serious bodily harm or death from asphyxiation. **MAKE SURE THE FLOW OF COMBUSTION AND VENTILATION AIR IS NOT RESTRICTED.**

**⚠ DANGER**

**Carbon Monoxide Warning**

- Follow all vent system requirements by the local authorities having jurisdiction over your installation.
- Failure to do so can result in death, explosion or carbon monoxide poisoning.

## Relief Valves (T&P)

All water heaters must be installed with a proper temperature and pressure relief valve. These valves must be certified as meeting the requirements of the “**Standard for Temperature, Pressure, Temperature and Pressure Relief and Vacuum Relief**” CSA 4.4 in Canada. In the United States “**Relief Valves and Automatic Gas Shut-Off Devices for Hot Water Supply Systems**”, ANSI Z21.22 is applicable.

If this water heater has been exposed to flooding, freezing, fire or any unusual condition, do not put it into operation until it has been inspected and approved by a qualified professional. **THESE CONDITIONS CAN RESULT IN UNSEEN INTERNAL DAMAGE** which is not subject to warranty coverage.

## Backflow Prevention

Certain jurisdictions may require the installation of a backflow device (e.g., check valve) in the water supply line. Such a device will require the use of a system expansion tank of adequate size to control the thermal expansion generated during the heating cycle. Consult your water supplier or local plumbing authority.

**Important:** The supply water meter may have a built-in check valve device. Contact your local water authority.

**CAUTION**

Hydrogen gas can be produced in a hot water system served by this heater that has not been used for a long period of time (generally two (2) weeks or more). **Hydrogen gas is extremely flammable and can ignite when exposed to a spark or flame.** To reduce the risk of injury under these conditions, it is recommended that the hot water faucet be opened for several minutes at the kitchen sink before using any electrical appliance connected to the hot water system. Use caution in opening faucets. If hydrogen is present, there will probably be an unusual sound such as air escaping through the pipe as the water begins to flow. There should be no smoking or open flame near the faucet at the time it is open.

### III) INSTALLATION

#### Unpacking the Water Heater



#### WARNING

#### Excessive Weight Hazard

Use two or more people to move and install water heater. Failure to do so can result in back or other injury.

**Important:** Do not remove any permanent instructions, labels or the rating plate from the outside of the water heater or on the inside of panels.

1. Move the water heater to the location of installation before removing the exterior packaging.
2. Remove exterior packaging and place installation components aside.
3. Inspect all parts for damage prior to installation and start-up.
4. Completely read and understand all instructions before attempting to assemble and install this product.

If you observe damage to the water heater or any of its components, DO NOT ASSEMBLE OR INSTALL IT OR MAKE ANY ATTEMPT TO FIX THE DAMAGED PART(S). Contact the place of purchase for further instructions.

5. After installation, dispose of packaging material in the proper manner.

#### Location Requirements

#### IMPORTANT:

This water heater must be installed strictly in accordance with the instructions enclosed, and local electrical, fuel and building codes. It is possible that connections to the water heater, or the water heater itself, may develop leaks. IT IS THEREFORE IMPERATIVE that the water heater be installed so that any leakage of the tank or related water piping is directed to an adequate drain in such a manner that it cannot damage the building, furniture, floor covering, adjacent areas, lower floors of the structure or other property subject to water damage. This is particularly important if the water heater is installed in a multi-story building, on finished flooring or carpeted surfaces. THE MANUFACTURER WILL NOT ASSUME ANY LIABILITY for damage caused by water leaking from the water heater, pressure relief valve, or related fittings. Select a location as centralized within the piping system as possible. In any location selected, it is recommended that a suitable drain pan be installed under the water heater. This pan must limit the water level to a MAXIMUM depth of 45mm (1 3/4 in.) and have a diameter that is a minimum of 50mm (2 in.) greater than the diameter of the water heater. Suitable piping shall connect the drain pan to a properly operating floor drain. When used with a fuel-fired heater, this drain pan must not restrict combustion air flow.

**Note:** Before installing this water heater, consideration and planning must be given to the following details:

- Location and Clearances.
- Access for gas supply; See “Gas Supply”.

- How and where to obtain combustion and ventilation air supply; See “Air Requirements”.
- Routing and support of the vent piping.
- Position of water supply and placement of water piping for hot and cold water; See “Water Supply”.
- Floor drain and service.

#### In Earthquake Zones

**Note:** The water heater must be braced, anchored, or strapped to avoid moving during an earthquake. Contact local utilities for code requirements in your area.

**Note:** REVIEW SAFETY WARNINGS FOUND IN THE FRONT OF THIS MANUAL BEFORE PROCEEDING

#### Clearances and Accessibility

Specific clearance locations are shown in Figure 3. A minimum of 600mm (24 in.) of front clearance shall be provided for inspection and service. We recommend that 0.9m (36 in.) above be maintained for serviceability.

Locate the water heater such that all controls are easily accessible, and the rating plate is visible.

Clearance to combustibles varies by model. Refer to rating plate to confirm clearances.

Heaters with a volume of 19 gallons through 50 gallons and 60 gallon (standard input) must have the following minimum clearances to combustibles:

Front	102mm (4 in.)
Sides and Rear	25mm (1 in.)
Top	203mm (8 in.)
Flue	152mm (6 in.)

JW6058 and G6058 (high input) series heaters must have the following minimum clearances to combustibles:

Front	127mm (5 in.)
Sides and Rear	25mm (1 in.)
Top	203mm (8 in.)
Flue	152mm (6 in.)

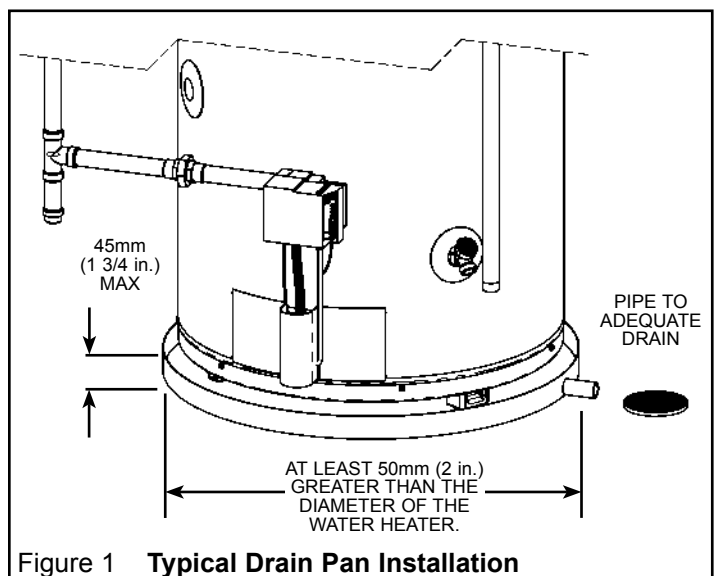

The 60 gallon heater is equipped with a Heat Reflector Shield (see Figure 2). This Shield reflects heat from the High-input heaters to prevent damage to combustible floors. The Shield is held in place by three (3) tabs that rest on the inside of the legs of the water heater. Ensure the Shield is positioned horizontally (parallel to the bottom of the heater) and in the designated position of 38mm (1.5 in.) below the flame-arrestor.

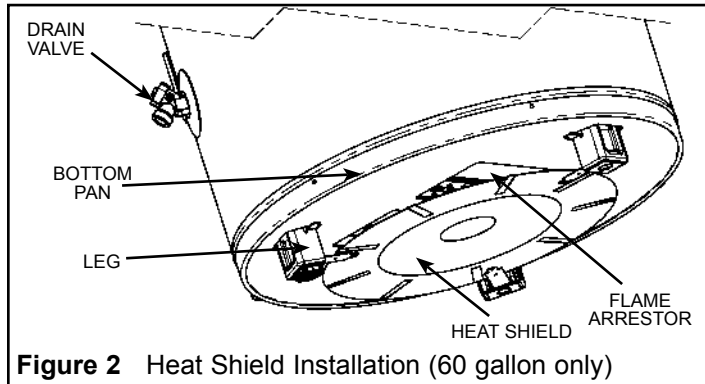

**Figure 2** Heat Shield Installation (60 gallon only)

**WARNING**

Do not install directly on carpet. Instead, place the water heater on a metal or wood panel extending a minimum of 75mm (3 in.) from all sides. In alcoves or closets, cover the carpet completely. Ensure this panel is capable of supporting the weight of this heater when filled with water.

**FAILURE TO PROPERLY INSTALL THIS HEATER MAY RESULT IN A FIRE HAZARD.**

The water heater shall be located in an area not subject to freezing temperatures. Water heaters located in unconditioned spaces (e.g., attics, basements, etc.) may require insulation of the water and drain piping to protect against freezing. Proper ventilation needs to be provided for water heaters installed in unconditioned spaces (e.g., attics, basements, etc.) in order to avoid an event where air temperature exceeds 42°C (108°F). The drain and controls must be easily accessible for operation and service. Maintain proper clearances as specified on the data plate.

Ensure that the water heater is level. This heater may be installed in a closet or alcove and is certified for operation on a combustible floor.

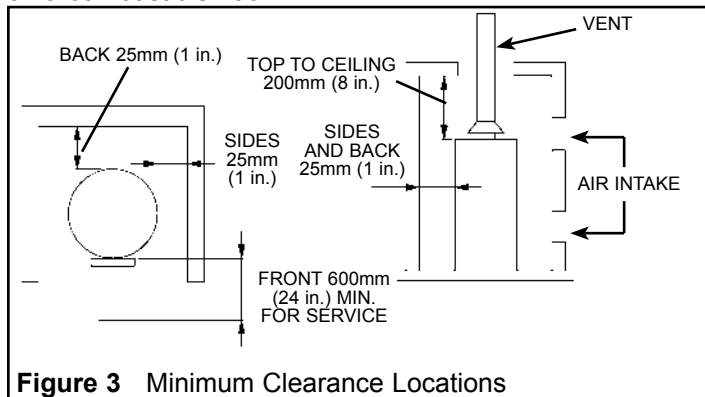

**Figure 3** Minimum Clearance Locations

Do not locate the water heater near an air-moving device. The operation of air-moving devices such as exhaust fans, ventilation systems, clothes dryers, fireplaces, etc., can

affect the proper operation of the water heater. Special attention must be given to conditions these devices may create. Flow reversal of flue gases may cause an increase of carbon monoxide inside of the dwelling, as shown in Figure 7.

If the water heater is located in an area that is subject to an excessive amount of lint, dirt or oil, it may be necessary to clean the flame arrestor periodically (see "Maintenance" section).

**Important:** It is always recommended that a suitable drain pan be installed under the water heater to protect the area from water damage resulting from normal condensation, a leaking tank or piping connections. Refer to Figure 1. Under no circumstances is the manufacturer to be held responsible for any water damage in connection with this water heater.

**Gas Supply**

Install the gas piping as shown in Figure 4. Use only new pipe and fittings with clean-cut threads. Sealing compounds used on the pipe threads shall be approved for use with natural and propane gas.

Use gas piping of adequate sizing to ensure gas input. Gas piping material must be approved for use with natural gas and propane fuels. All piping must comply with all local codes and with the latest edition of "Natural Gas and Propane Installation Code" CSA-B149.1 in Canada, "National Fuel Gas Code" ANSI Z223.1 (NFPA 54) in the U.S.A. The final connection to the water heater is made using 1/2" NPT.

Before connecting to the gas service, check that a properly sized gas meter and regulator are available to service the water heater. If other appliances are using the same meter and regulator, ensure that the capacity of the meter and regulator matches that of the combined input of all appliances connected to it.

**DO NOT** tamper with the gas control/thermostat, igniter, thermocouple, or temperature and pressure relief valve. Tampering voids all warranties. Only a qualified service technician should service these components.

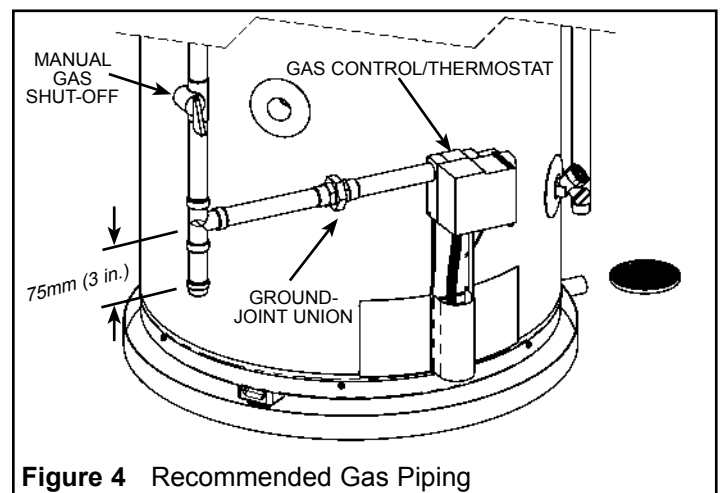

**Figure 4** Recommended Gas Piping

## Gas Pressure

### **WARNING**

**Exposure to a higher gas supply pressure may cause damage to the control, resulting in explosion or fire. Consult your local gas supplier and gas authorities. DO NOT PUT INTO SERVICE IF OVER-PRESSURIZATION HAS OCCURRED.**

The Manufacturer recommends that the gas supply pressure, as measured on the inlet side of the water heater control, be set at 7.0 in. w.c. (1.7 kPa) for natural gas and 11.0 in. w.c. (2.7 kPa) for propane gas. The above pressures must be measured during water heater operation.

The gas control supplied with this water heater is designed for a maximum inlet pressure of 0.5 psi (14 in. w.c.). Do not exceed this limit. The Flame Guard™ safety system is designed to operate within the pressure ranges shown in Table 1. Rated manifold pressures are indicated on the rating plate of the water heater.

Rated Manifold Pressure. in. w.c. (kPa)	Min. Manifold Pressure. in. w.c. (kPa)	Max. Manifold Pressure. in. w.c. (kPa)
10 (2.48)	9.2 (2.28)	10.2 (2.53)
5 (1.24)	4.5 (1.11)	5.1 (1.26)
4 (0.99)	3.6 (0.89)	4.4 (1.09)

**Table 1** Manifold Pressure

## Gas line purging

Gas line purging is required to eliminate air from the piping system. Purging should be performed by persons experienced in this type of gas service in compliance with the code having jurisdiction. Do not purge in confined areas or space where ignition may occur. To avoid risk of fire or explosion ensure the area is well ventilated and all sources of ignition are de-activated. Contact your local gas authority for local requirements.

## Gas Leak Testing

**Important:** This water heater and its gas connection must be tested for leaks before placing the appliance in operation. Perform a leak test at normal gas pressure. If the applicable code(s) require the gas lines to be tested at a pressure of 14 in. w.c. (3.5 kPa) or greater, the water heater and its manual shut-off valve must be disconnected from the gas supply piping system and the line capped. Test all connections of the gas system with a chloride-free soap and water solution or equivalent leak test liquid. Bubbles will indicate leaks. Never use a match or open flame to test for gas leaks. A fire or explosion could result. If leaks exist repair as required and retest.

DO NOT light the burner before the tank is filled with water and you have confirmed that there are no leaks in the piping and connections.

## Air Requirements

**Important:** Air for combustion and ventilation must not come from a corrosive atmosphere. Any failure due to corrosive elements in the atmosphere is excluded from warranty coverage.

Installations in or for certain places including, but not limited to, those listed below will require outdoor air for combustion due to chemical exposure:

- Beauty shops
- Photo processing labs
- Buildings with indoor pools
- Water heaters installed in laundry, hobby or craft rooms
- Water heaters installed near chemical storage areas

In such circumstances, outdoor combustion air may reduce, but will not eliminate, the presence of corrosive chemicals in the air. Combustion air must be free of acid-forming chemicals such as sulfur, fluorine and chlorine. These elements are found in aerosol sprays, detergents, bleaches, cleaning solvents, air fresheners, paint and varnish removers, refrigerants and many other commercial and household products. When burned, vapours from these products form highly corrosive acid compounds. These products should not be stored or used near the water heater or air inlet.

The area in which the heater is located is classified as either “**an unconfined space**” or “**a confined space**”.

An **unconfined space** is defined as a space having a volume not less than 50 cubic feet per 1000 BTU/hour (4.8 cubic metres per kilowatt) of combined input rating of all appliances using the space. Adjacent open rooms may be included as part of the unconfined space, provided there are no closeable doors between these rooms. An example of this is an open basement.

A **confined space** is one smaller than described above.

For buildings using tight construction (newer and renovated structures), the air supply shall be introduced from the outdoors, regardless of whether the space is confined or unconfined.

## Confined Space Air Requirements for Canadian Installations

Refer to Figure 5 (a), or (b), and Table 2 for proper sizing and location of combustion air ducts and openings. **CHECK LOCAL CODES.**

(a). Two permanent openings shall be provided connecting the confined space (e.g., closet, small room) with the unconfined space. Each opening shall have a free area of one square inch per 1,000 BTU/hour input (22 cm<sup>2</sup>/kW) of all appliances in the confined space. The top opening shall be located as close to the ceiling as practical but never lower than the top of the heater (see Figure 5 (a)). The bottom opening shall be located neither more than 450mm (18 in.), nor less than 150mm (6 in.), above floor level.

(b). When using a single air supply, the duct shall terminate within 300mm (12 in.) above and within 600mm (24 in.) horizontally of the burner level of the appliance having the largest input. For example: if the water heaters' burners are 150mm (6 in.) from the floor, plus 300mm

(12 in.) equals 450mm (18 in.) as shown in Figure 5 (b). All exterior vent openings are to be at least 300mm (12 in.) above the ground and clear of snow levels.

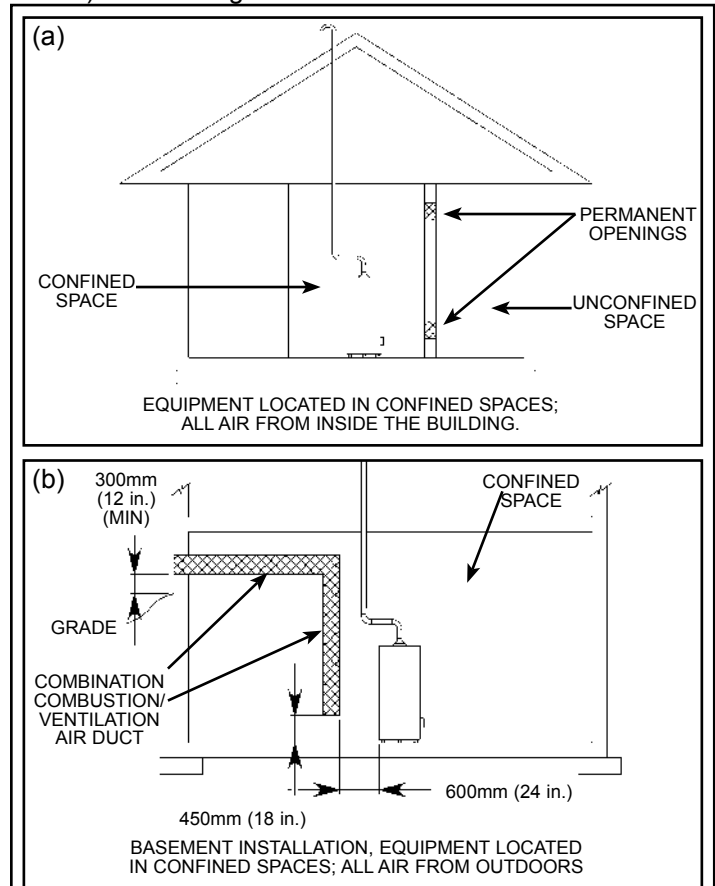

**Figure 5** Combustion Air Supply Openings And Ducts (Can.)

Combined Input of All Appliances in Confined Space*		Required Free Area		Acceptable Round Duct Size Diameter			
				A**		B***	
BTU/h	(kW/hr)	cm <sup>2</sup>	in. <sup>2</sup>	mm	in.	mm	in.
25,000	8	45	7	76	3	100	4
50,000	15	45	7	76	3	100	4
75,000	23	70	11	100	4	125	5
100,000	30	90	14	100	4	125	5
125,000	37	120	18	125	5	150	6
150,000	45	140	22	125	5	150	6

\* All appliances refers to, and includes, those appliances using the same air source (e.g. water heater, furnace, boiler, clothes dryer etc.).

\*\* Maximum allowable length of ductwork listed in column A is 6.1 equivalent metres (20 ft.).

\*\*\* Maximum allowable length of ductwork listed in column B is 15.2 equivalent metres (50 ft.).

**Table 2** Air Supply Sizing (Can.)



## Confined Space Air Requirements for U.S. Installations

Refer to Figure 6 (a), (b), (c) or (d) for proper sizing and location of combustion air ducts and openings. **CHECK LOCAL CODES.**

### (a) Equipment located in confined spaces; all air from inside the building.

Two permanent openings shall be provided connecting the confined space (e.g., closet, small room) with the unconfined space. Each opening shall have a free area of one square inch per 1,000 BTU/hour input ( $22 \text{ cm}^2/\text{kW}$ ) of all appliances in the confined space, but not less than 100 square inches ( $645 \text{ cm}^2$ ). The top opening shall commence within 300mm (12 in.) of the top of space and the bottom opening shall commence within 300mm (12 in.) of the bottom of the enclosure.

### (b) Basement installation, equipment located in confined spaces; all air from outdoors.

When supplying air directly from the outdoors, each opening shall have a minimum free area of one square inch per 4,000 BTU/hour input ( $5.5 \text{ cm}^2/\text{kW}$ ) of total input rating of all appliances in the confined space. The inlets shall be a minimum of 300mm (12 in.) above the grade (snow) line. The top opening shall commence within 300mm (12 in.) of the top of the confined space.

### (c) Equipment located in confined spaces; all air from outdoors.

When supplying air directly from the outdoors using horizontal ducting, each opening shall have a free minimum area of one square inch per 2,000 BTU/hour ( $11 \text{ cm}^2/\text{kW}$ ) of total input rating of all appliances in the confined space.

### (d) Equipment located in confined spaces; all air from outdoors through ventilated attic.

When supplying air directly through vertical ducting, each opening shall have a free minimum area of one square inch per 4,000 BTU/hour ( $5.5 \text{ cm}^2/\text{kW}$ ) of total input rating of all appliances in the confined space.

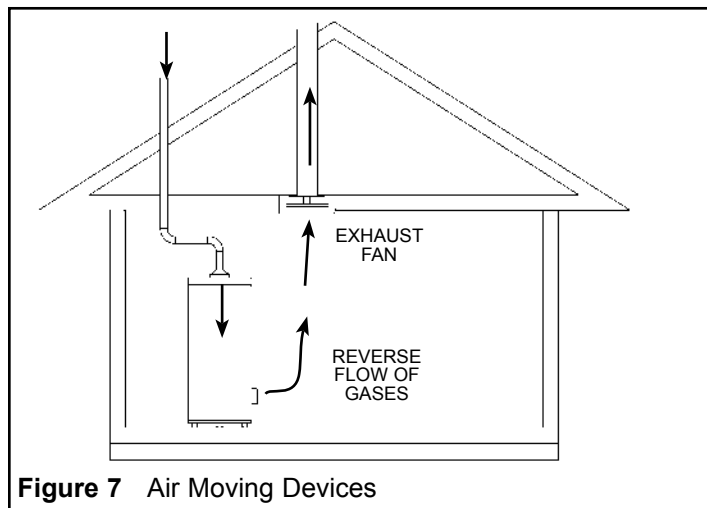

**Figure 7** Air Moving Devices

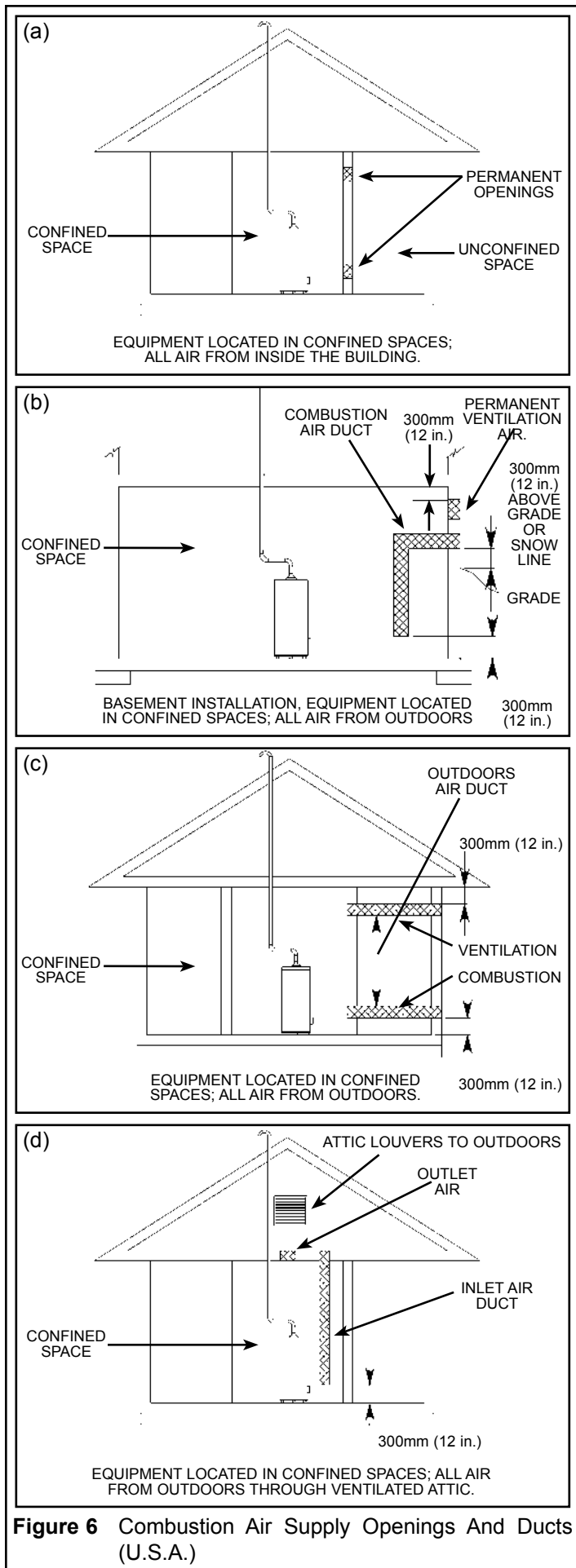

**Figure 6** Combustion Air Supply Openings And Ducts (U.S.A.)

## Exhaust Venting

### Vent Pipe System

This water heater is a Category 1, non-direct vented appliance. The vent pipe must be sized and installed in accordance with all local and provincial or state codes and with the latest edition of “**Natural Gas and Propane Installation Code**” CSA-B149.1 in Canada, “**National Fuel Gas Code**” ANSI Z223.1 (NFPA 54) in the U.S.A.

### Check for proper vent size

It is possible that the existing venting system was sized, for a previous installation, through a common vent. Such an arrangement is appropriate for venting two appliances such as the original water heater and a standard vent furnace. If this is true and the second appliance has been removed from the existing venting system (such as when the furnace has been upgraded to a power vent type), the venting system is now supplying only one appliance. This condition is commonly referred to as “orphaning” the water heater and the venting system must be properly resized for a single appliance. Improper sizing can cause a number of undesirable and potentially unsafe results including spillage of the products of combustion into the room, poor combustion, excessive condensation, pilot outage or delayed ignition. The vent pipe must not be obstructed so as to prevent the removal of exhaust gases to the outside atmosphere.

**Note:** The horizontal section of the vent must slope up 21mm per metre (1/4 in. per foot), (see Figure 8).

CSA/U.L. recognized fuel gas and carbon monoxide (CO) detectors are recommended in all applications and should be installed using the manufacturer’s instructions and local codes, rules or regulations.

**Important:** If you lack the necessary skills required to properly install this venting system, you should not proceed, but enlist the help of a qualified service technician.

### Drafthood Installation

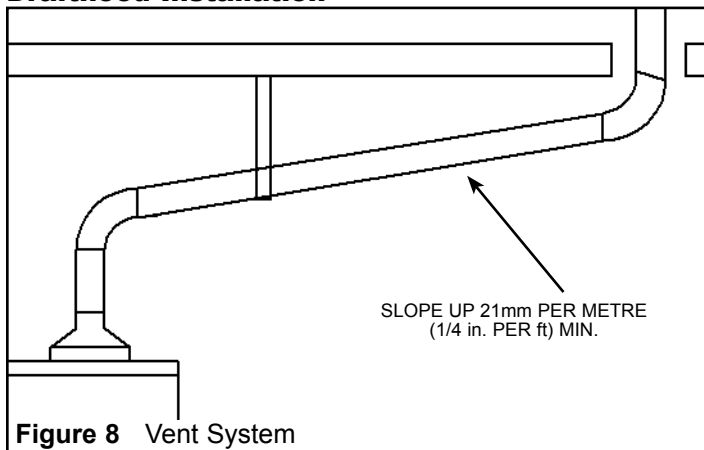

Figure 8 Vent System

## ⚠ WARNING



**Burn Hazard**  
Do not touch vent.  
Doing so can result in burns.

Hook the tab leg of the drafthood into the slot in the heater’s top or the flue damper if the heater is equipped with a flue damper. Align the remaining legs with the hole/dimples and secure the drafthood to the top with three screws as shown in Figure 9. Do not alter the drafthood in any way. If you are replacing an existing water heater be sure to use the new drafthood supplied with the water heater.

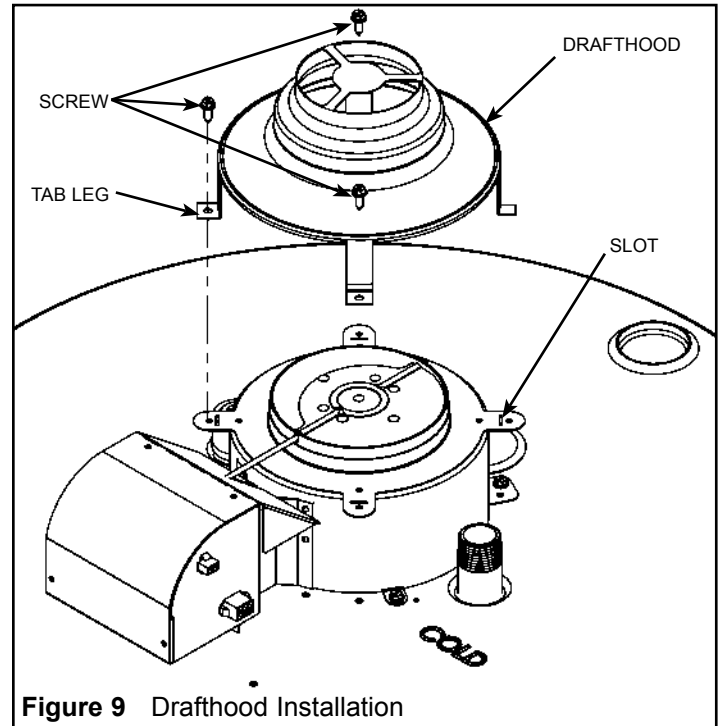

Figure 9 Drafthood Installation

## Water Supply

### Piping Installation

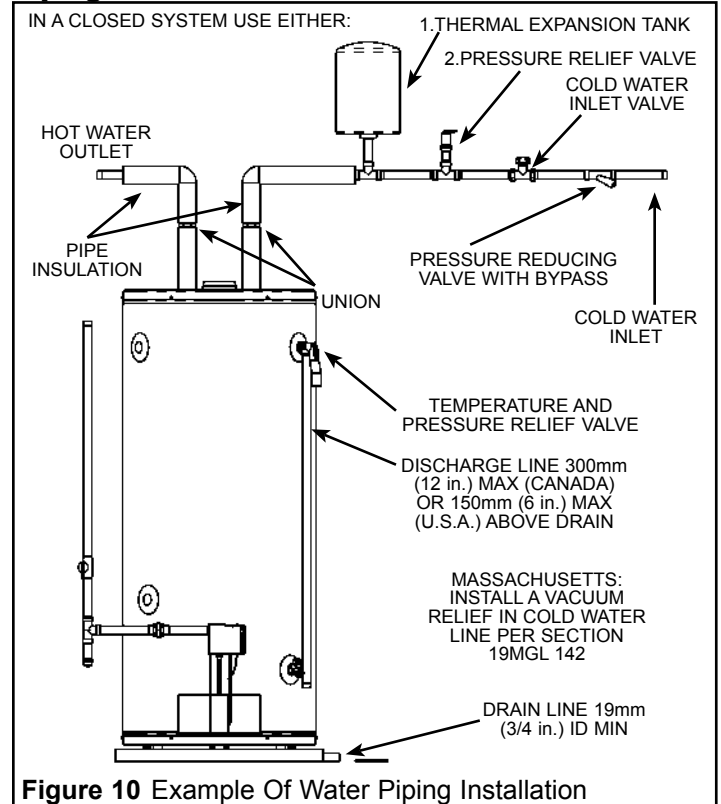

Figure 10 Example Of Water Piping Installation

Piping, fittings, and valves should be installed according to the installation drawing (Figure 10). If the indoor installation area is subject to freezing temperatures, the water piping must be protected by insulation. Water supply pressure should not exceed 550 kPa (80psi). If this occurs a pressure reducing valve and/or an expansion tank may be required. The pressure reducing valve should be placed on the supply to the entire house in order to maintain equal hot and cold water pressures.

**Important:** Heat must not be applied to the water fittings on the heater as they may contain nonmetallic parts. If solder connections are used, solder the pipe to the adapter before attaching the adapter to the hot and cold water fittings.

Install the water piping and fittings as shown in Figure 10. Connect the cold water supply to the fitting (3/4" NPT) marked "COLD" (or "C"). Connect the hot water supply to the fitting (3/4" NPT) marked "HOT" (or "H").

**Important:** Always use a good grade of joint compound, approved for use with potable water systems, and be certain that all fittings are drawn up tight.

**Important:** Some models may contain energy saving heat traps to prevent the circulation of hot water within the pipes. Do not remove, modify or tamper with the heat traps or any inserts within the heat traps.

### Union Connections

If a union connection is required we recommend raising the union above the draft-hood as illustrated in Figure 10. If galvanized piping is used, we recommend a galvanized nipple extension or a galvanized coupler with a pipe nipple to raise the union above the draft-hood. Same procedure applies if using copper.

Please note the following:

**DO NOT** install this water heater with iron piping. The system should be installed only with new piping that is suitable for potable (drinkable) water such as copper, CPVC or polybutylene. **DO NOT** use PVC water piping.

**DO NOT** use any pumps, valves or fittings that are not compatible with potable water.

**DO NOT** use valves that may cause excessive restriction to water flow. Use full flow ball or gate valves only.

**DO NOT** use any lead based solder in potable water lines. Use appropriate tin-antimony or other equivalent material.

**DO NOT** use with piping that has been treated with chromates, boiler seal or other chemicals.

**DO NOT** add any chemicals to the system piping that will contaminate the potable water supply.

## Mixing Valves

### WARNING

**Never allow small children to use a hot-water faucet, or to draw their own bath water. Never leave a child or impaired person unattended in a bathtub or shower. Scald burns can result.**

**Hot water can scald:** Water heaters are intended to produce hot water. Water heated to a temperature that will satisfy space heating, clothes washing, dish washing, and other sanitizing needs can scald and permanently injure you upon contact. Some people are more likely to be permanently injured by hot water than others. These include the elderly, children, the infirm, and physically/mentally handicapped.

If any one using the hot water fits into one of these groups or if there is a provincial, state or local code requiring a certain temperature water at the hot water faucet, then you must take special precautions. In addition to using the lowest possible temperature setting that will satisfy your hot-water needs, a means such as a mixing valve, should be used at the hot-water faucets or at the water heater. Mixing valves are available at plumbing supply or hardware stores. Follow manufacturer's instructions for installation of these valves. Before changing the factory settings on the thermostat, read the "Temperature Regulation" section in this manual.

## Closed System/Thermal Expansion

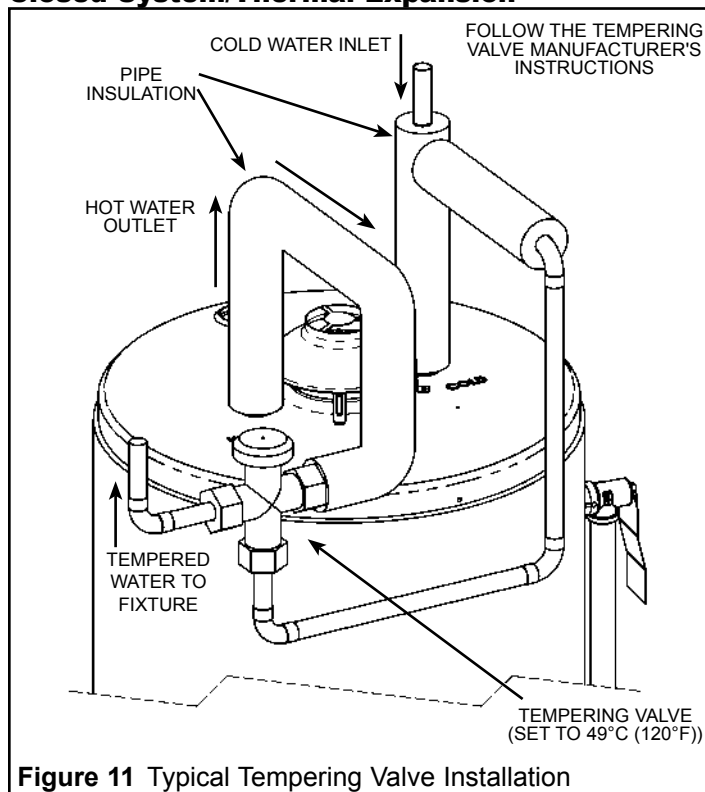

Periodic discharge from the temperature and pressure relief valve may be due to thermal expansion in a closed water supply system. The water utility supply meter may contain a check valve. This will create a closed water system. During the heating cycle of the water heater, the water expands

causing pressure inside the water heater to increase. This may cause the temperature and pressure relief valve to discharge small quantities of hot water. To prevent this from happening, there are two recommendations:

1. Install a diaphragm-type expansion tank that is suitable for potable water on the cold water supply line. The expansion tank must have a minimum capacity of 5.7 litres (1.5 US gallons) for every 190 litres (50 US gallons) of stored water and be rated for 150 psi or the working pressure of the water heater.
2. Install a pressure relief valve rated at max 125 psi in the cold water supply line. Make sure the discharge of this valve is directed to an open drain and protected from freezing. Contact the local water supplier or plumbing inspector for information on how to control this situation.

**Important:** Do not plug the temperature and pressure relief valve.

### Temperature and Pressure (T&P) Relief Valve

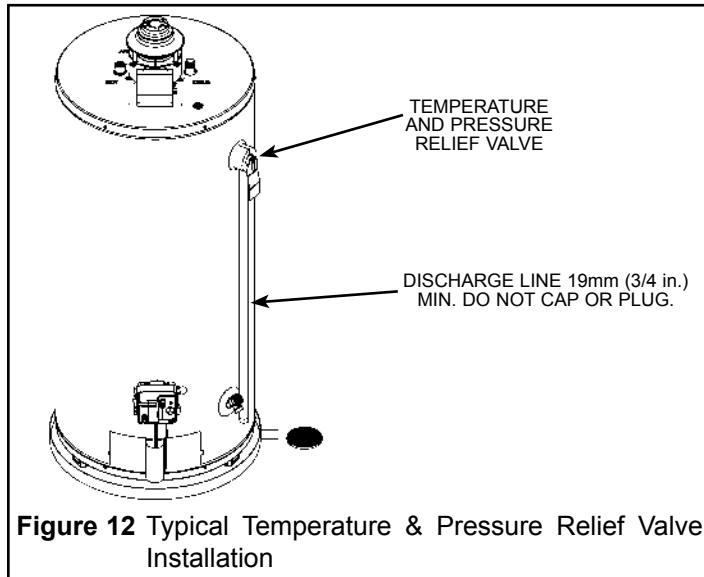

Refer to Figure 12 for a typical T&P valve installation. Important: Only a new temperature and pressure relief valve should be used with your water heater. Do not use an old or existing valve as it may be damaged or not adequate for the working pressure of the new water heater. Do not place any valve between the relief valve and the tank.

### The Temperature And Pressure Relief Valve:

- Must be connected to an adequate discharge line.
- Must not be rated higher than the working pressure shown on the data plate of the water heater.

### The Discharge Line:

- Must not be smaller than the pipe size of the relief valve or have any reducing coupling installed in the discharge line.
- Must not be capped, blocked, plugged or contain any valve between the relief valve and the end of the discharge line.
- Must terminate a maximum of 300mm (12 in.) max (Canada) or 150mm (6 in.) max (U.S.A.) above a floor drain or external to the building.
- Must be capable of withstanding 121°C (250°F) without distortion.
- Must be installed to allow complete drainage of both the valve and discharge line.
- Must not discharge so as to come in contact with any electrical part or wiring.

<b>WARNING</b> 
<b>Explosion Hazard</b>
<ul style="list-style-type: none"><li>• If the temperature and pressure relief valve is dripping or leaking, have a licensed plumber repair it.</li><li>• Do not plug valve.</li><li>• Do not remove valve.</li><li>• Failure to follow these instructions can result in death or an explosion.</li></ul>

## Electrical Supply

### **⚠ WARNING**

#### **Electrical Shock Hazard**



- Disconnect power before servicing.
- Replace all parts and panels before operating.
- Failure to do so can result in electrical shock.

### **24 Volt Control precautions**

(Applies to Honeywell control equipped heaters only).

**Important:** The electrical controls used inside the gas control/thermostat of this water heater are **polarity sensitive**. Ensure the electrical supply is connected correctly in the receptacle box. Failure to connect correctly will prevent the unit from functioning properly (see Figure 13). Before performing any electrical service work, label all wires to avoid connection errors. If wiring has to be replaced, use only **TYPE SPT-1** wire, (except igniter wires). If there is a problem with igniter wires, replace igniter assembly in its entirety. In locations where a sump pump failure, flooding or exposure to water may be present, a ground fault receptacle is recommended.

**Important:** Do not use an extension cord to connect the water heater to an electrical outlet.

- Ensure that the water heater and the outlet are properly grounded. Failure to properly ground the heater can prevent the unit from operating.
- Ensure that the water heater is installed in accordance with prevailing provisions of local codes and the latest edition of "Canadian Electrical Code (CAN/CSA C22.1), Part I" (Canada) or "National Electrical Code" (NFPA 70) (U.S.A.).

Before applying power to the water heater, always make sure:

- The voltage and frequency correspond to that specified on the water heater wiring diagram.
- The electrical circuit has the proper overload fuse or breaker protection.
- Fill the tank with water and check all connections for leaks. Open the nearest hot-water faucet and let it run for 3 minutes to purge the water lines of air and sediment and to ensure complete filling of the tank. The electrical power may then be turned on. Verify proper operation after servicing.

**Note:** Always reference the wiring diagram for the correct electrical connections.

The maximum wire length from transformer to the water heater is 15.2m (50 ft.) of **Type SPT-1** or equivalent.

### **⚠ WARNING**

When the unit is plugged in, 24VAC is present at the electric connections of the gas control/thermostat.

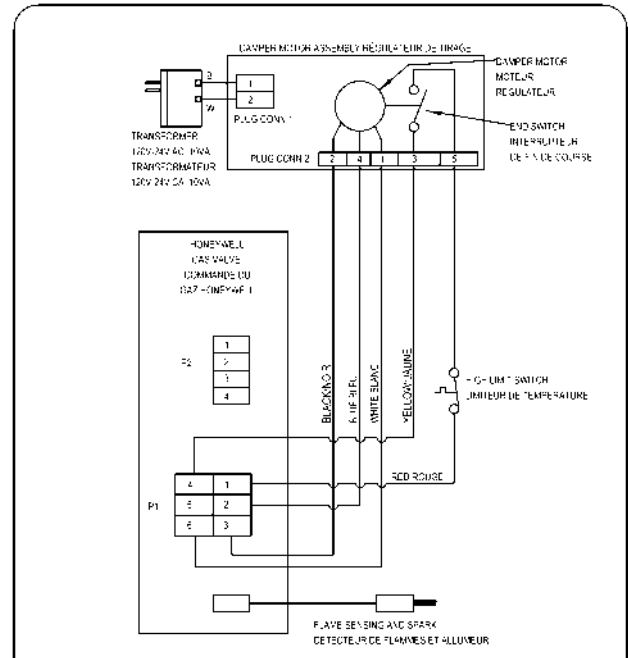

IF WIRING HAS TO BE REPLACED IN THE FIELD, USE ONLY TYPE TEW 105 C WIRE.  
 POUR LE REMPLACEMENT D'UN FIL ELECTRIQUE,  
 UTILISEZ QUE DU FIL DE TYPE TEW 105 C  
 ELECTRICAL RATING 24V 3A OR LESS 60 HZ  
 CAPACITE ELECTRIQUE 24V 3A OU MOINS, 60 HZ

320424-000

**Figure 13** Wiring Diagram - Honeywell (24 Volt)

## Installations Check

Check Here

- Have the safety precautions described in the manual been implemented?
- Does the gas piping conform to the recommendations of your Gas Utility Company?
- Has the gas piping been tested?
- Is the supply pressure correct?
- Is the water heater connected to the correct gas supply as shown on the rating plate (Natural Gas/Propane)?
- Is the clearance between the water heater and combustible construction as per specifications?
- Is the water piping correctly connected? Are you certain that there are no leaks?
- Is the water heater filled with water?
- Is the cold water supply valve open?
- Is the vent pipe installed properly and are the vertical and horizontal runs properly supported?
- Is the vent hood air intake opening unobstructed?
- Is the T&P valve installed? Are the drain pipe and T&P valve unobstructed?
- Is a drain pan installed with a proper overflow pipe, directed to a drain?
- Have you taken steps to prevent water damage in case of leaks?
- Does the area around the water heater have adequate ventilation?
- Air moving device does not create negative pressure?
- Flammable vapours are not placed in the proximity of the water heater?
- Manifold gasket properly sealed?
- Viewport not damaged or cracked?
- Flame-arrestor free of debris and undamaged?
- Two piece grommet on manifold door properly installed?
- No leaks at pilot and manifold connection?
- Manifold door screws securely tightened?
- Extra care for proper ventilation for attic or unconditioned space installation (max. air temperature 42°C (108°F))?

## IV) OPERATING INSTRUCTIONS

### Water Temperature Regulation

**HOT WATER CAN SCALD:** Water heaters are intended to produce hot water. Water heated to a temperature that will satisfy space heating, clothes washing, dish washing, and other sanitizing needs can scald and permanently injure you upon contact. Some people are more likely to be permanently injured by hot water than others. These include the elderly, children, the infirm, or physically/mentally handicapped. If anyone using hot water in your home fits into one of these groups or if there is a provincial, state law or local code requiring a specific hot water temperature at the tap, then you must take special precautions. Never allow small children to use a hot water tap, or to draw their own bath water. Never leave a child or handicapped person unattended in a bathtub or shower.

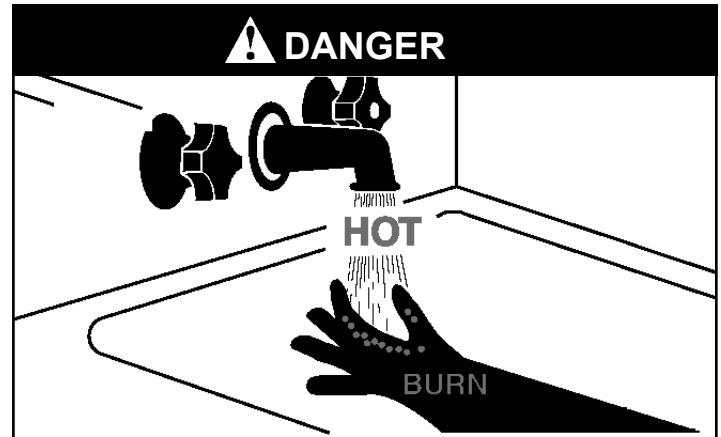

Water temperature over 52°C (125°F) can cause severe burns instantly or death from scalds.

Children, disabled and elderly are at highest risk of being scalded.

Feel water before bathing or showering.

Temperature limiting valves are available.

It is recommended that lower water temperatures be used to avoid the risk of scalding. It is further recommended, in all cases, that the water temperature be set for the lowest temperature that satisfies your hot water needs. This will also provide the most energy efficient operation of the water heater.

### **WARNING**

#### **Risk of scalding**

**There is a hot water scald potential if the thermostat is set too high.**

**Adjusting the thermostat past the 49°C (120°F) bar on the temperature dial will increase the risk of scald injury**



**Hot water can produce third degree burns**

**in 6 seconds at 60°C (140°F)**

**in 30 seconds at 54°C (130°F)**

**in 5 minutes at 49°C (120°F)**

## Temperature Adjustment

The thermostat of this water heater has been factory set at its lowest position. It is adjustable and must be set to the desired temperature setting. The preferred starting point is 49°C (120°F). Turn the water temperature dial clockwise  to decrease the temperature, or counterclockwise  to increase the temperature.

Figures 14 & 15 show the various thermostat settings. Short repeated heating cycles caused by small hot water uses can cause temperatures at the point-of-use to exceed the thermostat setting by up to 17°C (30°F). If you experience this type of use you should consider adding a mixing valve or using lower temperature settings to reduce scald hazards. Should overheating occur or the gas supply fail to shut off, turn off the manual gas control valve to the appliance and call for service.

Valves for reducing the point-of-use temperature by mixing cold and hot water are available (see Figure 11). Also available are inexpensive devices that attach to faucets to limit hot water temperatures. Contact a licensed plumber or the local plumbing authority.

**Note:** During low demand periods, a lower thermostat setting will reduce energy losses and may satisfy your normal hot water needs. If hot water use is expected to be more than normal, a higher thermostat setting may be required to meet the increased demand. When leaving your home for extended periods (e.g., vacations etc.) turn the temperature dial to its lowest setting. This will maintain the water at low temperatures with minimum energy losses and prevent the tank from freezing during cold weather.

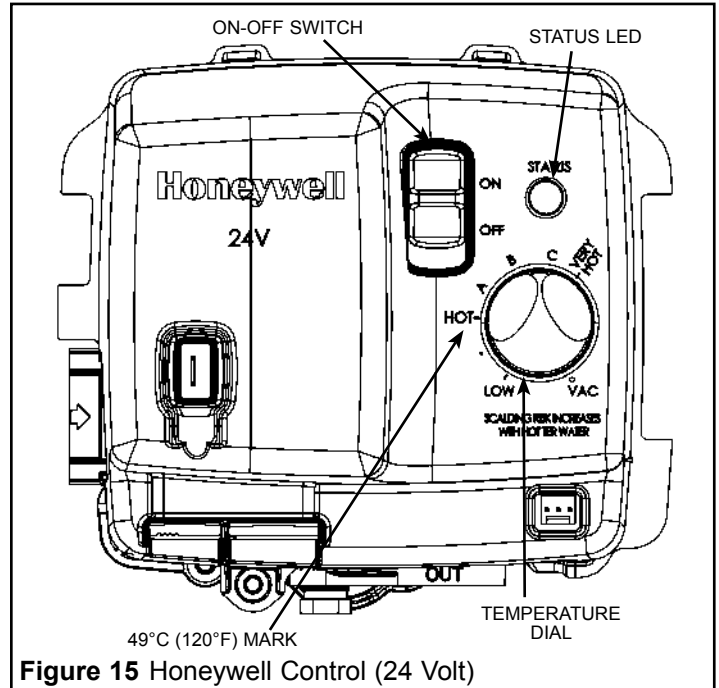
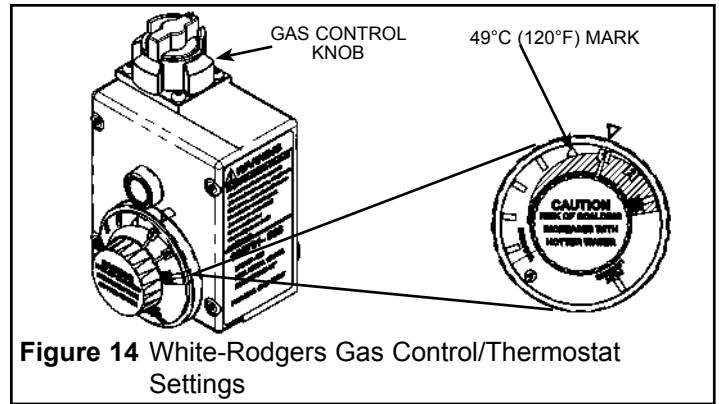

# Lighting Instructions (White-Rodgers 37C)

## FOR YOUR SAFETY READ BEFORE OPERATING

**WARNING:** If you do not follow these instructions exactly, a fire or explosion may result causing property damage, personal injury or loss of life.

- This appliance has a pilot that is lit by a piezo-electric spark gas ignition system. Do not open the inner door of the appliance and try to light the pilot by hand.
- BEFORE OPERATING** smell all around the appliance area for gas. Be sure to smell next to the floor because some gases are heavier than air and will settle on the floor.

### WHAT TO DO IF YOU SMELL GAS

- Do not try to light any appliance.
  - Do not touch any electric switch; do not use any phone in your building.
  - Immediately call your gas supplier from a neighbour's phone. Follow the gas supplier's instructions.
  - If you cannot reach your gas supplier, call fire department.
- Use only your hand to push in or turn the gas control knob. Never use tools. If the knob will not push in or turn by hand, don't try to repair it, call a qualified service technician. Force or attempted repair may result in a fire or explosion.
  - Do not use this appliance if any part has been under water. Immediately call a qualified service technician to inspect the appliance and to replace any part of the control system and any gas control which has been under water.

## POUR VOTRE SÉCURITÉ LISEZ AVANT DE METTRE EN MARCHÉ

**AVERTISSEMENT:** Quiconque ne respecte pas à la lettre les instructions dans la présente notice risque de déclencher un incendie ou une explosion entraînant des dommages, des blessures ou la mort.

- L'allumage de la veilleuse de cet appareil est assuré par un système d'allumage piézoélectrique à étincelles. Ne tentez pas d'ouvrir la porte d'accès interne et d'allumer la veilleuse manuellement.
- AVANT DE FAIRE FONCTIONNER**, renifllez tout autour de l'appareil pour détecter une odeur de gaz. Renifllez près du plancher, car certains gaz sont plus lourds que l'air et peuvent s'accumuler au niveau du sol.

### QUE FAIRE SI VOUS SENTEZ UNE ODEUR DE GAZ:

- Ne pas tenter d'allumer d'appareil.
  - Ne touchez à aucun interrupteur; ne pas vous servir des téléphones se trouvant dans le bâtiment.
  - Appelez immédiatement votre fournisseur de gaz depuis un voisin. Suivez les instructions du fournisseur.
  - Si vous ne pouvez rejoindre le fournisseur, appelez le service des incendies.
- Ne poussez ou tournez la manette d'admission du gaz qu'à la main; ne jamais utiliser d'outils. Si la manette reste coincée, ne tentez pas de la réparer; appelez un technicien qualifié. Le fait de forcer la manette ou de la réparer peut déclencher une explosion ou un incendie.
  - N'utilisez pas cet appareil s'il a été plongé dans l'eau, même partiellement. Faites inspecter l'appareil par un technicien qualifié et remplacez toute partie du système de contrôle et toute commande qui ont été plongés dans l'eau.

## LIGHTING AND OPERATING INSTRUCTIONS

- STOP!** Read the safety information above on this label.
- Set the thermostat to lowest setting.
- This appliance has a pilot that is lit by a spark gas ignition system. Do not try to light the pilot by hand.
- Remove the outer burner door.
- Push the gas control knob down slightly and turn clockwise ↻ to "OFF" (see Figure "A").

**NOTE:** Knob CANNOT be turned from "PILOT" to "OFF" unless it is pushed down slightly. Do not force.

- Wait ten (10) minutes to clear out any gas. Then smell for gas, including near the floor. If you smell gas, STOP! Follow "B" in the safety information above on this label. If you don't smell gas, go to the next step.
- Make sure the water heater is filled with water.
- Turn gas control knob counterclockwise ↻ to "PILOT" (see Figure "A").
- Depress the gas control knob all the way in and IMMEDIATELY depress the igniter button until you hear a loud click. Observe the pilot through the view port. Do not release the gas control knob. Repeat immediately if pilot does not light on the first try. If the pilot does not light by the fourth attempt with the igniter, repeat steps 5-9. Continue to hold the button for about one (1) minute after the pilot is lit. Release the gas control knob and it will pop back up. Pilot should remain lit. If the pilot light goes out, repeat steps 5-9.

**IMPORTANT:** If the pilot will not stay lit after several tries, turn gas control knob to "OFF" and call your service technician or gas supplier.

**IMPORTANT:** If the gas control knob does not pop up to its original position when released, stop and immediately shut off the gas at the line valve or tank. Call your service technician or gas supplier.

- Turn gas control knob counter-clockwise ↻ to "ON" (see Figure "A").
- Once the pilot flame is established replace the outer burner door.
- Set thermostat to desired setting.
- If the pilot will not stay lit after several tries, turn the gas control knob clockwise ↻ to "OFF" (see Figure "A"). If the appliance will not operate, follow the instructions "To Turn Off Gas To Appliance" and call a qualified service technician or gas supplier.

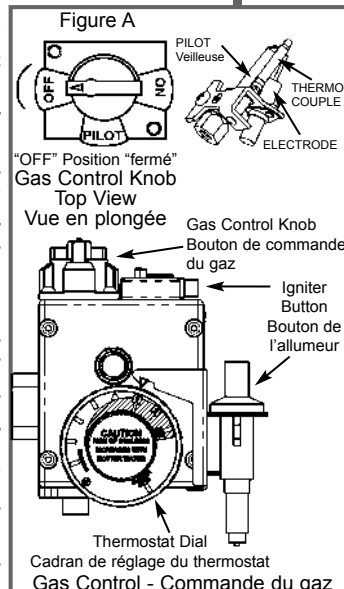

## DIRECTIVES D'ALLUMAGE ET DE MISE EN MARCHÉ

- ARRÊTEZ!** Lisez les instructions de sécurité sur la portion supérieure de cette étiquette.
- Réglez le thermostat à la température la plus basse.
- L'allumage de la veilleuse de cet appareil est assuré par un système d'allumage à étincelles. Ne tentez pas d'allumer la veilleuse manuellement.
- Enlevez la porte d'accès externe.
- Appuyez sur le bouton de commande du gaz et faites-le tourner dans le sens horaire ↻ jusqu'à "OFF" (Figure A).

**NOTE:** Il n'est PAS POSSIBLE de faire passer le bouton de "PILOT" à "OFF" à moins d'appuyer dessus. Ne le forcez pas.

- Attendre dix (10) minutes pour laisser échapper tout le gaz. Renifllez tout autour de l'appareil, y compris près du plancher, pour détecter une odeur de gaz. Si vous sentez une odeur de gaz, ARRÊTEZ! Passez à l'étape "B" des instructions de sécurité sur la portion supérieure de cette étiquette. S'il n'y a pas d'odeur de gaz, passez à l'étape suivante.
- Assurez-vous que le chauffe-eau est complètement rempli d'eau.
- Faites tourner le bouton de commande du gaz dans le sens antihoraire ↻ jusqu'à "PILOT" (Figure A).
- Enfoncez complètement le bouton de commande du gaz et appuyez IMMÉDIATEMENT sur le bouton de l'allumeur jusqu'à ce que vous entendiez un bon déclic. Observez la veilleuse par le regard de la chambre de combustion. Ne relâchez pas le bouton de commande du gaz. Répétez immédiatement la manœuvre si la veilleuse ne s'allume pas dès la première tentative. Si la veilleuse refuse toujours de s'allumer à la quatrième tentative avec l'allumeur, répétez les étapes 5 à 9 inclusivement. Continuez d'appuyer sur le bouton de commande du gaz pendant environ une (1) minute après l'allumage de la veilleuse. Relâchez le bouton de commande du gaz et il retournera à sa position initiale. La veilleuse devrait rester allumée. Si la veilleuse s'éteint, répétez les étapes 5 à 9 inclusivement.

**IMPORTANT:** Si la veilleuse ne reste pas allumée après plusieurs tentatives, tournez le bouton de commande du gaz jusqu'à "OFF" et appelez un technicien qualifié ou votre fournisseur de gaz.

**IMPORTANT:** Si le bouton de commande du gaz ne retourne pas à sa position initiale lorsque vous le relâchez, arrêtez et fermez immédiatement le gaz au régulateur principal ou au réservoir. Appelez un technicien qualifié ou votre fournisseur de gaz.

- Faites tourner le bouton de commande du gaz dans le sens antihoraire ↻ jusqu'à "ON" (Figure A).
- Une fois la veilleuse allumée, remettez en place la porte d'accès externe.
- Réglez le thermostat à la température désignée.
- Si la veilleuse ne reste pas allumée après plusieurs tentatives, faites tourner le bouton de commande du gaz dans le sens horaire ↻ jusqu'à "OFF" (Figure A). Si l'appareil ne se met pas en marche, suivez les instructions intitulées "Comment couper l'admission des gaz de l'appareil" et appelez un technicien qualifié ou le fournisseur de gaz.

## TO TURN OFF GAS TO APPLIANCE

- Set thermostat to the lowest setting (PILOT LIGHTING).
- Push the gas control knob down slightly and clockwise ↻ to the "OFF" position. Do not force.

## COMMENT COUPER L'ADMISSION DES GAZ DE L'APPAREIL

- Réglez le thermostat à la température la plus basse (ALLUMAGE DE LA VEILLEUSE).
- Appuyez sur le bouton de commande du gaz et faites-le tourner dans le sens horaire ↻ jusqu'à "OFF". Ne le forcez pas.

71731



# Lighting Instructions (Honeywell 24 Volt)

## FOR YOUR SAFETY READ BEFORE LIGHTING

**WARNING:** If you do not follow these instructions exactly, a fire or explosion may result causing property damage, personal injury or loss of life.

**BEFORE LIGHTING: ENTIRE SYSTEM MUST BE FILLED WITH WATER AND AIR PURGED FROM ALL LINES**

- A. This appliance is equipped with an ignition device which automatically lights the pilot. Do NOT try to light the pilot by hand.
- B. BEFORE OPERATING smell all around the appliance area for gas. Be sure to smell next to the floor because some gas is heavier than air and will settle on the floor.

### WHAT TO DO IF YOU SMELL GAS

- Do not try to light any appliance.
  - Do not touch any electric switch; do not use any phone in your building.
  - Immediately call your gas supplier from a neighbor's phone. Follow the gas supplier's instructions.
  - If you cannot reach your gas supplier, call the fire department.
- C. Use only your hand to turn the control knob. Never use tools. If the knob will not turn by hand, don't try to repair it, call a qualified service technician. Force or attempted repair may result in a fire or explosion.
- D. Do not use this appliance if any part has been under water. Immediately call a qualified service technician to inspect the appliance and to replace any part of the control system and any gas control which has been under water.

## POUR VOTRE SÉCURITÉ, LISEZ ATTENTIVEMENT AVANT L'ALLUMAGE

**AVERTISSEMENT:** Tout manquement aux présentes directives peut causer un incendie ou une explosion résultant en des dommages matériels, des blessures ou la mort.



**AVANT L'ALLUMAGE: LE RÉSEAU D'ALIMENTATION EN EAU DOIT ÊTRE ENTIÈREMENT REMPLI D'EAU ET L'AIR ENTIÈREMENT PURGÉ**

- A. Cet appareil est muni d'un dispositif d'allumage automatique de la veilleuse. NE tentez PAS d'allumer le brûleur manuellement.
- B. AVANT LA MISE EN MARCHÉ, humez tout autour de l'appareil afin de détecter une éventuelle odeur de gaz. Sentez aussi près du sol, car certains gaz sont plus lourds que l'air et s'y accumulent.

### SI VOUS DÉTECTEZ UNE ODEUR DE GAZ



- Ne mettez aucun appareil en marche.
  - N'actionnez aucun interrupteur électrique; n'utilisez aucun téléphone de votre bâtiment.
  - Appelez immédiatement votre fournisseur de gaz depuis un voisin et suivez les instructions du fournisseur.
  - Si vous ne pouvez joindre votre fournisseur de gaz, appelez le Service des incendies.
- C. Utilisez uniquement vos mains pour faire tourner le bouton de réglage du gaz, n'utilisez jamais d'outils. Si vous n'arrivez pas à le faire tourner à la main, ne tentez pas de le réparer; appelez un technicien d'entretien qualifié. Si vous forcez ou tentez de réparer le bouton, il a risque d'explosion ou d'incendie.
- D. N'utilisez pas cet appareil même s'il n'a été que partiellement submergé par de l'eau. Appelez immédiatement un technicien d'entretien qualifié afin qu'il inspecte l'appareil et remplace toute partie du système de contrôle et de commande ayant été plongée dans l'eau.

## OPERATING INSTRUCTIONS

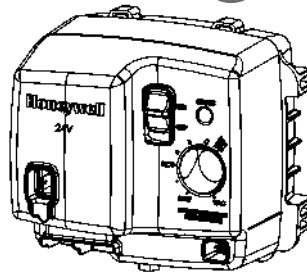
1.  STOP! Read the safety information above on this label.
2. Turn off all electric power to the appliance.
3. Turn the thermostat counter-clockwise to the lowest setting.
4. Do not attempt to light manually.
5. Set the switch on the control to the "OFF" position.
6. Wait five (5) minutes to clear out any gas. If you then smell gas, STOP!  Follow "B" in the safety information above on this label. If you don't smell gas, go the next step.
7. Set the switch on the control to the "ON" position.
8. Turn thermostat to desired setting.
9. Turn on all electric power to the appliance.
10. If the appliance will not operate, follow the instructions "To Turn Off Gas To Appliance" and call your service technician or gas supplier.



## DIRECTIVES D'UTILISATION

1.  ARRÊTEZ! Lisez les directives de sécurité au haut de cette étiquette.
2. Coupez toutes les sources d'alimentation électrique de l'appareil.
3. Réglez le thermostat à sa plus basse valeur (sens antihoraire).
4. Ne tentez pas d'allumer le brûleur manuellement.
5. Réglez le sélecteur du régulateur du gaz à la position "OFF".
6. Attendez cinq minutes afin de laisser se dissiper tout gaz ayant pu s'accumuler. Si vous détectez une odeur de gaz, ARRÊTEZ!  Suivez la directive de sécurité "B" au haut de cette étiquette. Si vous ne détectez pas d'odeur de gaz, passez à la prochaine étape.
7. Réglez le sélecteur du régulateur du gaz à la position "ON".
8. Réglez le thermostat à la température désirée.
9. Réalimentez l'appareil en électricité.
10. Si l'appareil ne se met pas en marche, suivez la directive "Couper l'alimentation en gaz de l'appareil" et appelez un technicien d'entretien qualifié ou votre fournisseur de gaz.

## TO TURN OFF GAS TO APPLIANCE

1. Turn the thermostat counter-clockwise to the lowest setting.
2. Set the gas control switch "OFF".

## COUPER L'ALIMENTATION EN GAZ DE L'APPAREIL

1. Réglez le thermostat à sa plus basse valeur (sens antihoraire).
2. Réglez le sélecteur du régulateur du gaz à la position "OFF".

318132-000

## V) OPERATION

### Burner Flames

Inspect the burner flames through the viewport and compare them to the drawings in Figure 16. A properly operating burner should produce a soft blue flame. Blue tips with yellow inner cones are satisfactory. The tips of the flame may have a slight yellow tint. The flame should not be all yellow or have a sharp blue-orange color. Contaminated air may cause an orange colored flame. Contact a qualified service technician if the flame is not satisfactory.

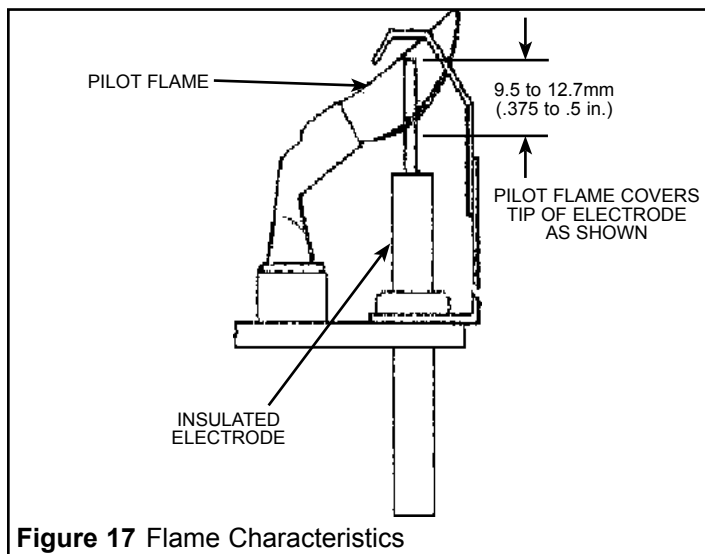
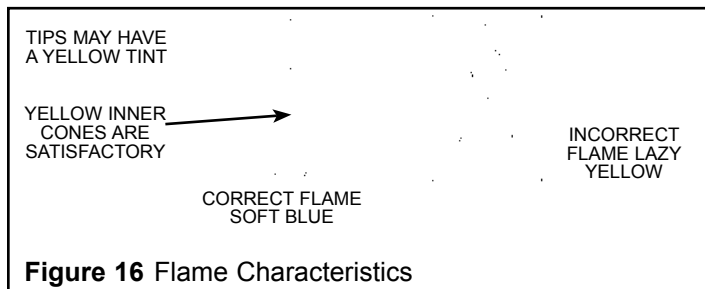

For models with a 24 Volt control and flue damper, the recommended spark gap between the igniter sensor and grounding strap is 3.2mm (.125 in.). The pilot flame should envelop 9.5 to 12.7mm (.375 to .5 in.) of the tip of the insulated rod or the igniter.

### Emergency Shut Down

**Important:** Should overheating occur or the gas supply fail to shut off, turn off the water heater's manual gas shut-off valve and call a qualified service technician (see Figure 4).

### Checking the Draft

After successfully lighting the water heater, allow the unit to operate for 15 minutes and check the drafthood relief opening for proper draft. Pass a match flame around the relief opening of the drafthood as shown in Figure 18 & 19. A steady flame drawn into the opening indicates proper draft. If the flame flutters or is blown out, combustion products are escaping from the relief opening. If this occurs, do not operate the water heater until proper adjustments or repairs are made to the vent pipe system.

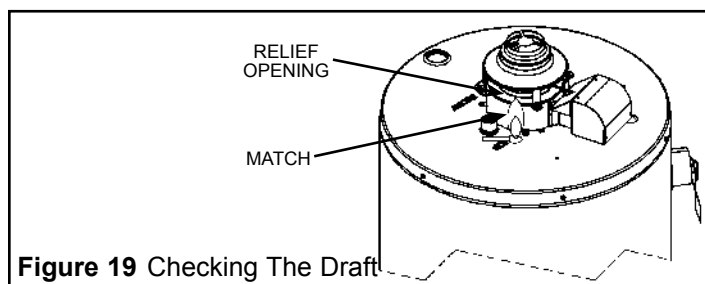
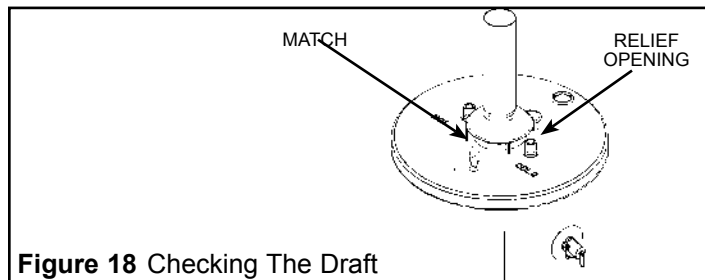

### Operating Conditions

#### Condensation

Moisture from the products of combustion condenses on the tank surface and forms drops of water which may fall onto the burner or other hot surfaces. This will produce a "sizzling" or "frying" noise. This condensation is normal and should not be confused with a leaking tank. Condensation may increase or decrease at different times of the year. Highly efficient energy saver water heaters will produce larger amounts of condensation on initial start up or when a large amount of hot water is being used. Once the water reaches a temperature of 49°C (120°F) and the tank warms up (usually about 1 hour), the condensation will stop.

**Note:** At initial start-up, in certain extremely cold conditions and if the water heater is not allowed enough time to reach the room temperature, the pilot burner might be extinguished in the first 20 minutes from start-up due to heavy condensation. In this situation if the unit is relit, it will follow its normal heating cycle without further incidents. After installation always allow the water heater to reach the room temperature before the initial start-up is initiated. Supervise the flame inside the water heater at least 20 minutes at initial start-up to ensure that heavy condensation is not turning off the water heater.

## Water Heater Sounds

During the normal operation of the water heater, sounds or noises may be heard. These noises are common and may result from the following:

- Normal expansion and contraction of metal parts during the periods of heat-up and cool-down.
- Condensation causing sizzling and popping within the burner area.
- Sediment build up in the tank bottom creating varying amounts of noise. Build up may cause premature tank failure. Drain and flush the tank as directed under "Draining and Flushing".

## Safety Shut-off

This water heater is designed to automatically shut-off in the event of the following:

- The pilot flame is extinguished for any reason.
- The water temperature exceeds 93°C (200°F).
- Excessive combustion chamber temperatures.
- The ignition of flammable vapours.
- Excessive lint and or dust build-up

A dual safety switch is part of the water heater safety system. The gas control is connected to a door-mount, manually resettable safety switch which is designed to disable the gas control/thermostat in the event of excessive combustion chamber temperatures or a flammable vapour incident. If the thermal switch opens, the water heater cannot be used unless this thermal switch is reset by a qualified service technician.

### Milli-volt Models:

A thermocouple is used to determine if a pilot flame is present and will shut off the gas supply to the main burner and the pilot burner if the flame is absent.

### 24 Volt/Damper Models:

The 24 Volt control valve is in constant communications with the different components that are connected to it, ensuring all components are in the proper positions and in working order.

The gas control has a high temperature limit switch or ECO (Energy Cut Off) which is used to shut off the unit if the water temperature exceeds 93°C (200°F). The ECO is resettable. If the ECO has shutdown the water heater, the water heater cannot be used until the gas control has been inspected by a qualified service technician. Contact your local dealer or a qualified service technician for service information.

## Anode/Water Odour

Each water heater contains at least one anode, which will slowly deplete while protecting the glass-lined tank prolonging the life of the water heater. Certain water conditions may cause a reaction between the anode and the water. The most common complaint associated with the anode is a "rotten egg smell" produced by the presence of sulfur. Do not remove this anode permanently as it will void any warranties, stated or implied. An aluminum anode may reduce if not eliminate water odour problems. The water supply system may require special filtration equipment from a water conditioning company to successfully eliminate all water odour problems.

Artificially softened water is exceedingly corrosive because the process substitutes sodium ions for magnesium and calcium ions. The use of a water softener may decrease the life of the water heater tank. The anode should be inspected periodically. If the anode is more than 50% depleted, the anode should be replaced.

## Water Heater Operation (24 Volt only)

Thermostat calls for heat

Within 15 seconds:

- Vent damper rotates to open position
- Vent damper opening is confirmed and an electrical signal is sent to the ignition system in the controller

Within 30 seconds:

- Ignition system is powered and
- Lights the pilot
- Confirms pilot ignition
- Allows the main valve to open
- Burner ignites

At the end of the "On Cycle":

- The thermostat contacts open
- The ignition system closes the gas valve
- Burner shuts "off"
- The vent damper starts to close

Within 30 seconds:

- The vent damper is fully closed

### System Error Codes for 24 Volt Controls

The micro-controller inside the gas control monitors the TCO safety feature, the ignition sequence, temperature settings and overall operation of the heater. If any of these parameters does not operate properly the controller will shut down the water heater, diagnose the failure and flash an error code. Table 3 lists the system status Codes for the 24 Volt Honeywell control.

**Note:** If a random power outage is experienced, your water heater may experience a soft lockout for approximately 2 minutes. This lockout is required to allow the control to reset itself.

If the gas control valve is submerged under water for any length of time, the gas control valve assembly should be replaced.

LED FLASH SEQUENCE	CONTROL STATUS
Short flash once every four seconds	IDLE (no call for heat, no fault conditions)
"Heartbeat", alternates bright/dim	Call For Heat (no fault conditions)
One Flash, three second pause	Low Flame Signal (control continues to operate)
Two Flash, three second pause	End Switch Failed Closed
Three Flash, three second pause	TCO or End Switch Failed Open
Four Flash, three second pause	ECO Limit Lockout
Five Flash, three second pause	Flame Out Of Sequence
Six-One Flash, three second pause	Soft Lockout - Retry Limit - Failed TFI
Six-Two Flash, three second pause	Soft Lockout - Recycle Limit - PS/Limit opened
Six-Three Flash, three second pause	Soft Lockout - Recycle Limit - Flame Lost
Six-Four Flash, three second pause	Soft Lockout - Flame out of Sequence Sensed
Seven Flash, three second pause	Flammable Vapor Sensor Lockout
Eight-One Flash, three second pause	FVS Fault Detected
Eight-Two Flash, three second pause	Temperature Sensor Fault Detected
Eight-Three Flash, three second pause	Electronics Fault Detected
Eight-Four Flash, three second pause	Valve Fault Detected
<b>Table 3</b> Status Codes (Honeywell)	

## VI) MAINTENANCE

The installation and maintenance of the water heater must comply with all of the instructions described in sections I to IX of this manual. Water heater failure that is a result of the heating system is not covered by warranty.

### Periodic Cleaning of the Wrap-around Filter

1. If inspection of the filter shows a build-up on the filter, it should be cleaned.
2. The filter can be vacuumed to remove the build-up.
3. A visual inspection of the flame-arrestor is also recommended. Refer to “External Cleaning of the Flame-arrestor”.

**Note:** Visually inspect the flame arrestor by placing a mirror underneath the water heater. A flashlight can be used to illuminate the slots in the flame arrestor if necessary. Routine cleaning of the flame arrestor is recommended if inspection shows accumulation of debris on the flame arrestor. See section titled “External Cleaning of the Flame-arrestor” for cleaning instructions.

### Draining and Flushing

It is recommended that the tank be drained and flushed every 6 months to remove sediment which may buildup during operation. The water heater should be drained if being shut down for extended periods of time. To drain the tank, perform the following steps:

1. Turn off the gas to the water heater with the manual gas shut-off valve.
2. Close the cold water inlet valve.
3. Open a nearby hot water faucet.
4. Connect a hose to the drain valve and terminate it to an adequate drain.

**Note:** The drain hose should be rated for at least 94°C (200°F). If the drain hose does not have this rating, open the cold water inlet valve and nearby hot faucet until the water is no longer hot.

5. Open the water heater drain valve and allow all the water to drain from the tank. Flush the tank with water as needed to remove sediment.
6. Close the drain valve, refill the tank, and restart the heater as directed under “Operating Instructions”. If the water heater is going to be shut down for an extended period, the drain valve should be left open.

**Important:** Condensation may occur when refilling tank and should not be confused with a tank leak.

The following maintenance procedures are for the Flame Guard™ safety system components and should be performed by a qualified service technician.

Replacement parts (see Figures 29-33) may be ordered through your local distributor. When ordering replacement parts, always have the following information ready:

1. Model, serial and product number.
2. Type of gas.
3. Item number.
4. Parts description.

### Periodic Inspection

Periodically a visual inspection should be made of the venting and air supply system, piping systems, main burner, pilot burner and flame arrestor.

Check the water heater for the following:

1. Obstructions, damage or deterioration in the venting system. Make sure the ventilation and combustion air supplies are not obstructed.
2. Build-up of soot and carbon on the main burner and pilot burner. Check for a soft blue flame.
3. Leaking or damaged water and gas piping.
4. Presence of flammable or corrosive materials in the installation area.
5. Presence of combustible materials near the water heater.
6. Presence of debris on the outside of the flame arrestor. See note below.

**Important:** Verify proper operation after servicing this water heater. If you are unsure of this inspection procedure or the proper operation of the water heater and its special safety features, enlist the services of a qualified service technician.

### External Cleaning of the Flame-arrestor

**Important:** It is recommended that the flame arrestor be visually inspected periodically for accumulation of dust, lint and other debris, especially if the heater is installed in areas having a high dust and/or lint content. Any such accumulation should be cleaned as outlined below.

1. Use a vacuum cleaner to remove all loose debris in the flame arrestor.
2. If necessary, a soft bristle brush can be used to dislodge any remaining debris.
3. Repeat step 1 as necessary to completion.

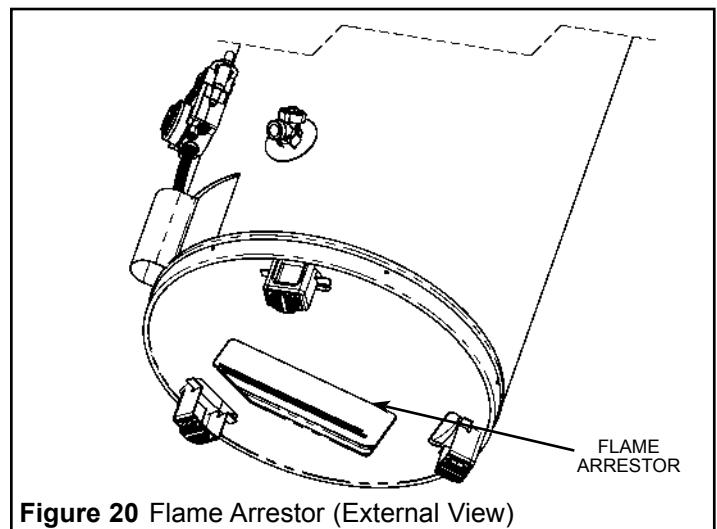

Figure 20 Flame Arrestor (External View)

## Temperature and Pressure Relief Valve

Manually operate the temperature and pressure relief valve at least once a year to make sure it is working properly. To prevent water damage, the valve must be properly connected to a discharge line which terminates at an adequate drain. Standing clear of the outlet (discharged water may be hot), slowly lift and release the lever handle on the temperature and pressure relief valve (see Figure 21) to allow the valve to operate freely and return to its closed position. If the valve fails to completely reset and continues to release water, immediately shut off the manual gas shut-off valve and the cold water inlet and call a qualified service technician.

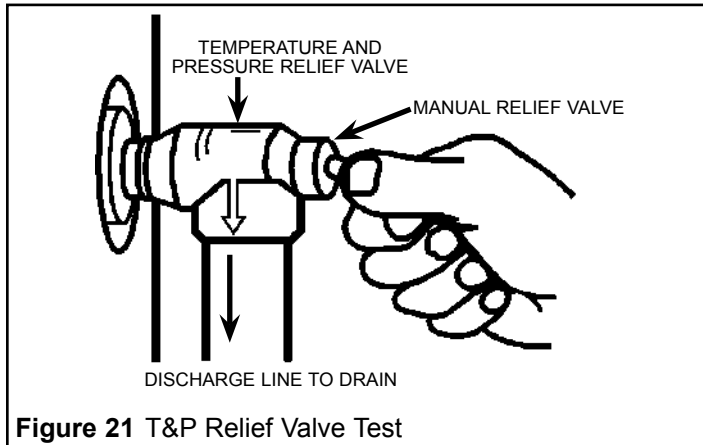

Figure 21 T&P Relief Valve Test

## Resetting and Replacing the Safety (TCO) Switch (NG models)

The (NG) water heater safety system includes a door-mount, manual resettable, safety switch which is designed to disable the gas control/thermostat in the event of excessive combustion chamber temperatures. The excessive combustion chamber temperatures may be generated by accumulation of lint and dust on the flame-arrestor (located underneath the combustion chamber).

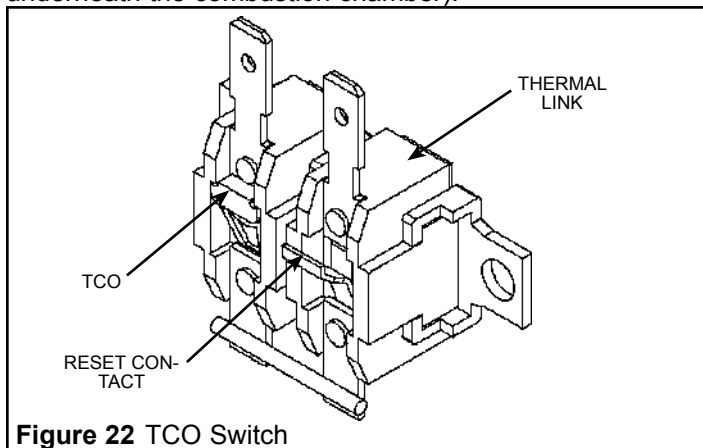

Figure 22 TCO Switch

1. Follow first the procedure outlined in "External Cleaning of the Flame-arrestor".
2. Remove the outer door and locate the TCO switch on the right side of the combustion chamber door.
3. Manually press the contact located on the front-right side of the TCO switch (Figure 22) until a click sound is generated. Do not use a metal tool or a screwdriver to press the TCO switch contact.

4. Verify if the quick connects are firmly inserted in the TCO switch contacts.
5. Replace the outer door.
6. Restart the water heater following the "Operating Instructions".
7. If the pilot burner does not stay lit after several attempts it is possible that the TCO embedded in the safety switch opened due to a flammable vapour incident or the TCO switch was severely damaged. Do not attempt to further operate the water heater. Call a qualified service technician.

## Replacing the Thermocouple (TCO) Assembly (LP models)

In LP water heaters a high temperature limit switch or TCO (Temperature Cut Off) in the manifold assembly is used to shut off the unit if the temperature in the combustion chamber exceeds 238°C (460°F). The TCO is a single use switch and requires replacement of the entire thermocouple. If the TCO should operate, the water heater cannot be used until the thermocouple is replaced by a qualified service agency. Contact your local dealer for service information.

1. Refer to Figure 31 to locate and identify the major components of the manifold assembly. The LP configuration is shown.
2. The thermocouple routing and TCO location is important for the proper operation of this water heater. A kit with a replacement thermocouple, complete with bending and installation instructions, is available from authorized distributors.
3. Make note of the path of the faulty thermocouple before removing it. Then follow the bending and routing instructions, included with new thermocouple, to match the path of the original thermocouple in your water heater.

**Important:** Do not bend the thermocouple assembly in the section where the TCO is located.

**Note:** All maintenance and service work must be performed by a qualified service technician.

## 24 Volt Honeywell Control Service

Some heaters covered by this manual come equipped with a 24 volt vent damper and a Modular Honeywell Gas Control. Both the Electronic Control Module and the Valve Module of this control may be changed without the need to disconnect the threaded control fitting from the body of the water heater. Almost all gas valve failures will be corrected by replacing the Electronic Control Module (ECM). If replacing the ECM does not correct the problem, contact technical service at 1-888-479-8324 or online at techsupport@gsw-wh.com.

### Electronic Control Module Replacement

Do not remove the entire gas control assembly from the water heater. To remove the Electronic Control Module:

1. Remove the front Torx screw and the 2 molex connectors from the bottom of the gas control as illustrated in Figure 23.
2. Use a flat-blade screwdriver to release the two tabs at the top of the gas control and lift the electronic control straight up (see Figures 24 & 25).
3. Disconnect the temperature sensor cable.

**Note:** When removing the control module from the gas control assembly, care is required to disengage the pins on the valve module.

4. Re-assemble in the reverse order.

**Note:** Care is required to align the pins on the valve module to their proper location in the control module during re-assembly.

### Valve Module Replacement

Do not remove the entire gas control assembly from the water heater. To remove the Valve Module:

1. Remove the Electronic Control Module as outlined above.

**Note:** When removing the control module from the gas control assembly, care is required to disengage the pins on the valve module.

2. Remove the screw and the ground tab with a Torx screwdriver (see Figure 26).
3. Insert a flat-blade screwdriver between the casting and the locking tabs at the bottom of the valve.
4. Carefully pry against the casting until it barely slides past the locking tab edge.
5. Repeat on the opposite side.
6. Replace the valve module.

**Note:** Use caution when replacing the valve to not apply pressure with the hand on the valve pins.

7. Re-assemble in the reverse order.

**Note:** Care is required to align the pins on the valve module to their proper location in the control module during re-assembly.

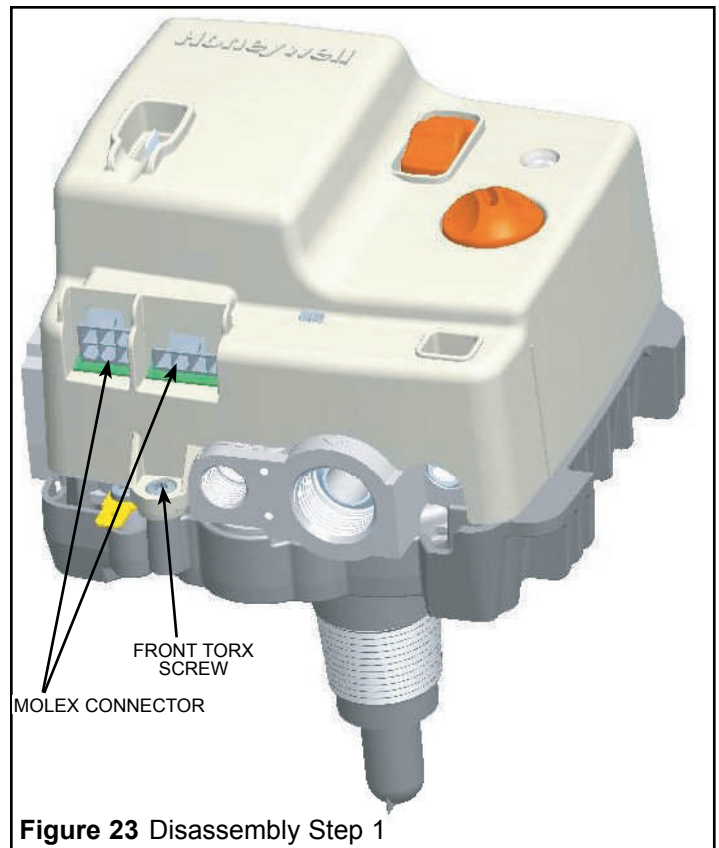

Figure 23 Disassembly Step 1

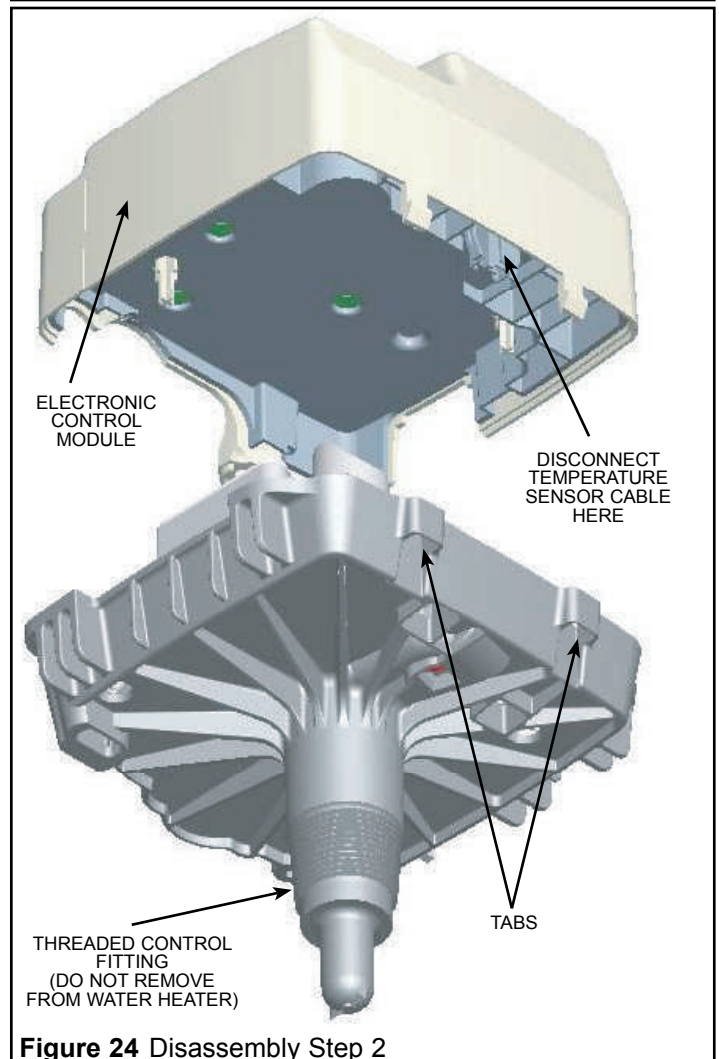

Figure 24 Disassembly Step 2



## Temperature Sensor and Cable Replacement

Do not remove the entire gas control assembly from the water heater. To remove the Temperature Sensor and Cable:

1. Remove the Electronic Control Module as outlined above.
2. Remove the Valve Module as outlined above.
3. Use a screwdriver to pry under the sensor retainer finger to remove the temperature sensor and cable (see Figure 27).
4. Re-assemble in the reverse order.

**Note:** When removing the control module from the gas control assembly, care is required to disengage the pins on the valve module.

**Note:** Use caution when replacing the valve to not apply pressure with the hand on the valve pins.

**Note:** Care is required to align the pins on the valve module to their proper location in the control module during re-assembly.

When re-installing the gas control assembly, we recommend using Teflon tape on the threaded control fitting.

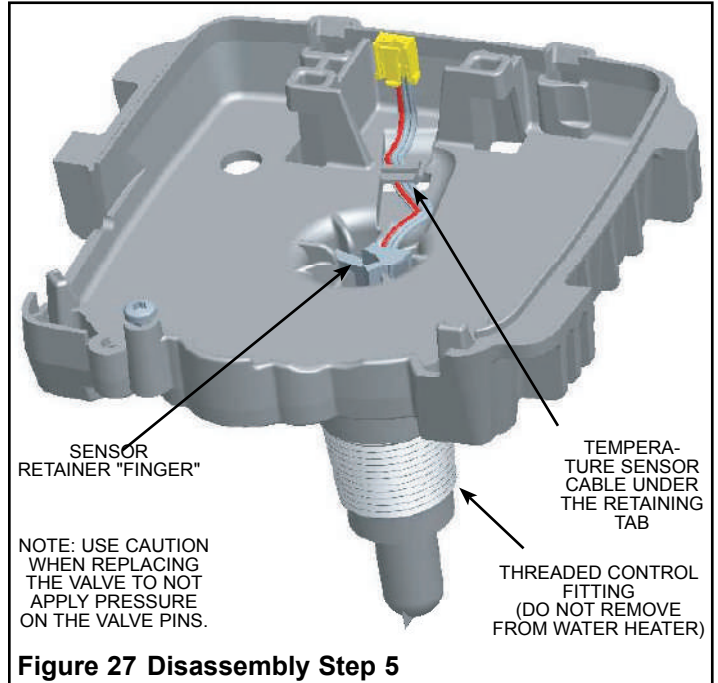

Figure 27 Disassembly Step 5

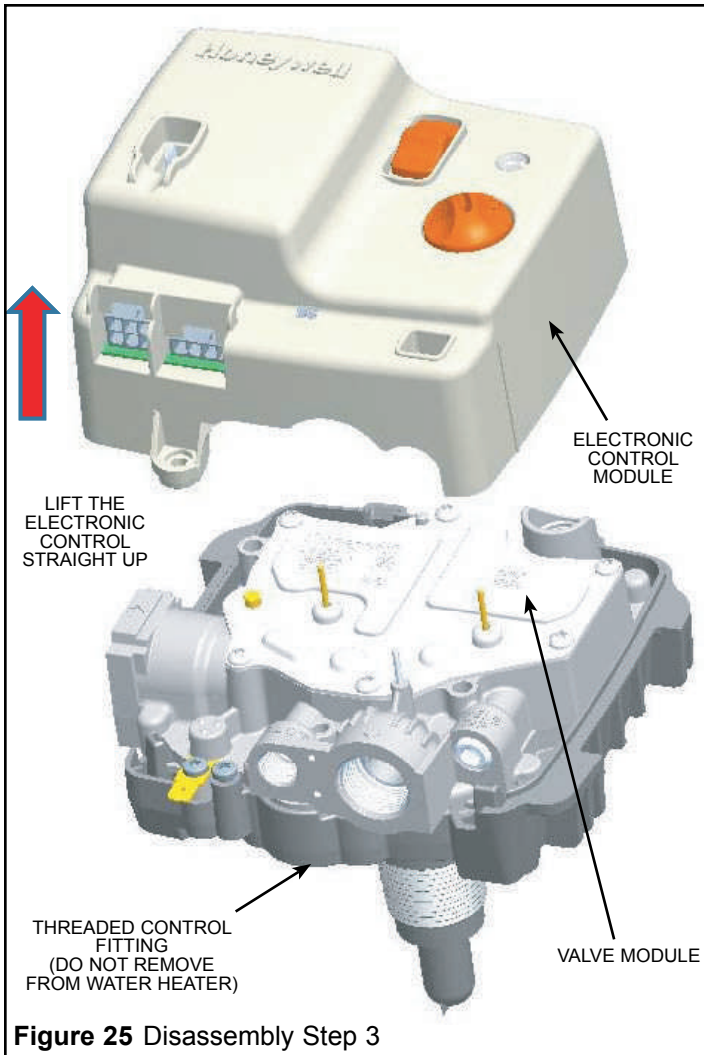

Figure 25 Disassembly Step 3

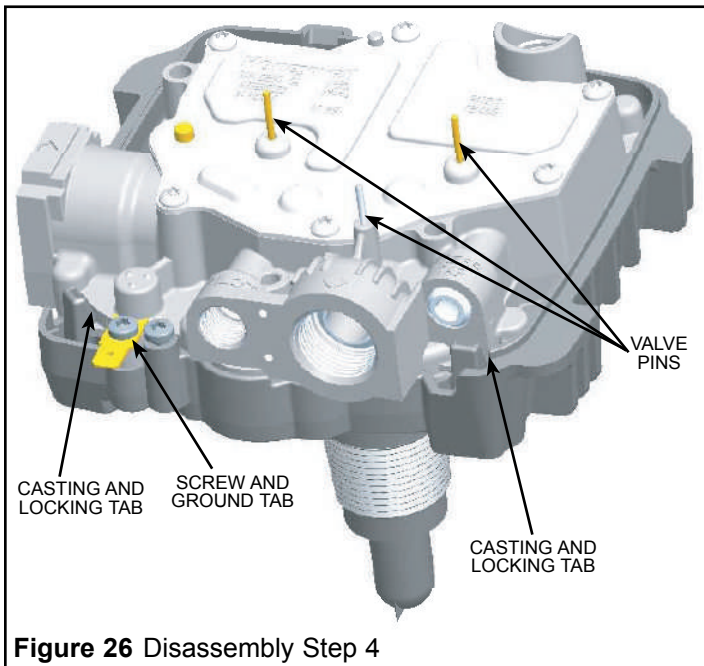

Figure 26 Disassembly Step 4



## VII) COMBO HEATING

This section serves as a guide for the installation and use of “Combo” heating systems utilizing a domestic water heater which has been specifically approved for such use (see Figure 28). It is written for those knowledgeable in the required trades and professionals involved in the design and installation of Combo Heating Systems.

It is the responsibility of the installer/designer to follow all applicable codes to ensure the effectiveness and safety of the installation.

### System Requirements

The following requirements must be met for the installation of Combo Heating Systems:

1. The piping and components connected to the water heater for the space heating applications shall be suitable for use with potable water. The system should be installed with new, non-ferrous piping. Do not use pumps, valves, fittings, solder, gluing and pipe sealant that are not completely compatible with potable water piping.
2. A water heater which will be used to supply potable water must not be connected to any heating system or components previously used with a non-potable water heating appliance. Do not use piping that has been treated with chromates, broiler seal or other chemicals and do not add chemicals to the water heating piping. Do not introduce toxic chemicals, such as those used for boiler treatment, into the potable water used for space heating.
3. Do not use this heater as a replacement for an existing boiler installation.
4. If the space heating water system requires water with temperatures in excess of 60°C (140°F), a mixing valve, or other means to temper the water and reduce scald hazard potential, must be installed in the potable hot water supply.
5. If the heater is installed with a back-flow preventer on the incoming water line or in a closed system, a diaphragm-type expansion tank must always be installed in the system to prevent the T&P from relieving due to thermal expansion.
6. Proper sizing of the water heater for the given space and potable heating application is essential to ensure adequate heating capacity. The sizing and installation of such combination system must be performed by qualified personnel and be in accordance with public utility requirements and/or codes having jurisdiction.

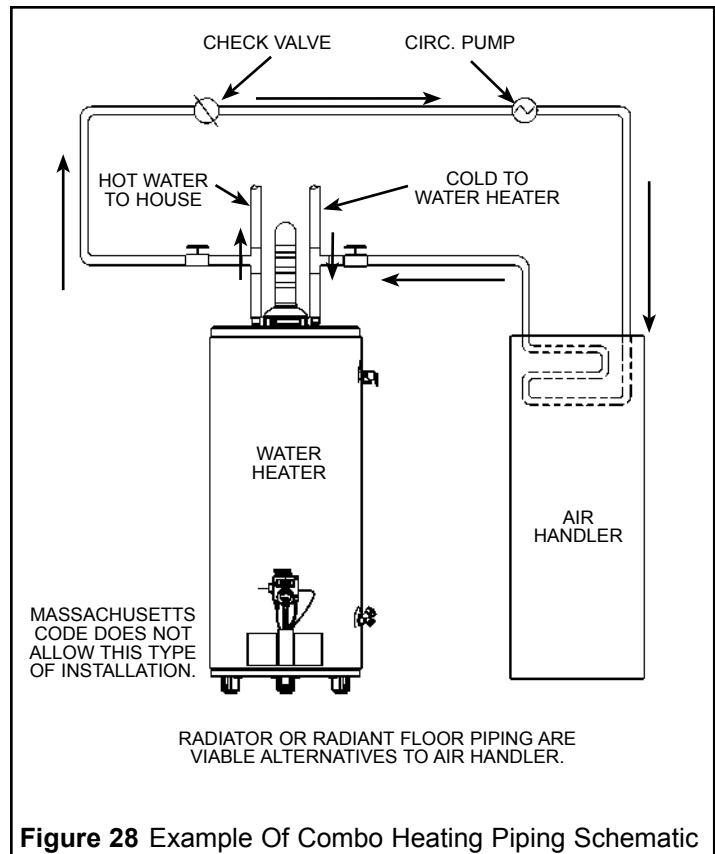

**Figure 28** Example Of Combo Heating Piping Schematic

The sizing of the water heater should be based on the design heat loss of the structure to be heated plus the potable water requirements.

**IT IS IMPORTANT THAT THE WATER HEATER USED BE SIZED PROPERLY TO ALLOW ADEQUATE HEATING AND POTABLE WATER HEATING CAPACITY.**

## VIII) TROUBLESHOOTING GUIDE

**Note:** Troubleshooting must be done by qualified service personnel familiar with the start up and check out procedure.

**Note:** The latest version of the installation and operating instructions manual can be found at [www.johnwoodwaterheaters.com](http://www.johnwoodwaterheaters.com)

PROBLEM	POSSIBLE CAUSE(S)	CORRECTION
BURNER WILL NOT IGNITE (FOR 24V CONTROLS ONLY)	<ol style="list-style-type: none"> <li>1. No Power to Unit</li> <li>2. Thermostat setting too low</li> <li>3. Defective flue damper</li> <li>4. Disconnected or loose wire</li> <li>5. Control lock-out</li> <li>6. Door-mount temperature cut-off (TCO) switch was activated.</li> <li>7. No gas</li> <li>8. Dirt in the pilot or gas line</li> <li>9. Plugged pilot or burner orifice</li> <li>10. Defective gas control valve</li> <li>11. Defective igniter</li> <li>12. Heater installed in a confined area</li> </ol>	<ol style="list-style-type: none"> <li>1. Plug in power cord, check fuses/supply voltage</li> <li>2. Increase thermostat temperature setting</li> <li>3. Replace flue damper</li> <li>4. Repair or reconnect wires</li> <li>5. Reset-determine cause of lockout.</li> <li>6. Call a qualified service technician</li> <li>7. Check with the gas utility company</li> <li>8. Notify gas utility. (Note: It is highly recommended that a trap is installed in the gas line.)</li> <li>9. Clean, locate source and correct</li> <li>10. Refer to "24 Volt Honeywell Control Service" section</li> <li>11. Replace igniter</li> <li>12. Provide more air ventilation</li> </ol>
BURNER FLAME YELLOW-LAZY	<ol style="list-style-type: none"> <li>1. Insufficient secondary air</li> <li>2. Low gas pressure</li> <li>3. Flue clogged</li> <li>4. Main burner line clogged</li> <li>5. Heater installed in a confined area</li> <li>6. Obstruction in main burner orifice</li> </ol>	<ol style="list-style-type: none"> <li>1. Provide ventilation to water heater</li> <li>2. Check with gas utility company</li> <li>3. Clean, locate source and correct</li> <li>4. Clean, locate source and correct</li> <li>5. Proper fresh air ventilation</li> <li>6. Clean or replace orifice</li> </ol>
PILOT FLAME TOO SMALL	<ol style="list-style-type: none"> <li>1. Pilot line or orifice clogged</li> <li>2. Low gas pressure</li> <li>3. Defective pilot</li> </ol>	<ol style="list-style-type: none"> <li>1. Clean, locate source and correct</li> <li>2. Check with gas utility company</li> <li>3. Replace pilot</li> </ol>
INSUFFICIENT HOT WATER	<ol style="list-style-type: none"> <li>1. Thermostat set too low</li> <li>2. Sediment or lime in tank</li> <li>3. Water heater too small</li> <li>4. Wrong piping connections</li> <li>5. Leaking faucets</li> <li>6. Wasted hot water</li> <li>7. Long runs of exposed piping</li> <li>8. Hot water piping in outside wall</li> <li>9. Low gas pressure</li> </ol>	<ol style="list-style-type: none"> <li>1. Turn temperature dial to desired setting</li> <li>2. Drain/flush-provide water treatment if needed</li> <li>3. Install adequate size heater</li> <li>4. Correct piping-dip tube must be in cold inlet</li> <li>5. Repair faucets</li> <li>6. Advise customer</li> <li>7. Insulate piping</li> <li>8. Insulate piping</li> <li>9. Check with gas utility company</li> </ol>
SLOW HOT WATER RECOVERY	<ol style="list-style-type: none"> <li>1. Insufficient secondary air</li> <li>2. Flue clogged</li> <li>3. Low gas pressure</li> <li>4. Improper calibration</li> <li>5. Gas control/thermostat set too low</li> <li>6. Water heater too small</li> <li>7. Wrong piping connections</li> <li>8. Wasted hot water</li> </ol>	<ol style="list-style-type: none"> <li>1. Provide ventilation to water heater. Check flue way, flue baffle and burner</li> <li>2. Clean flue, locate source and correct</li> <li>3. Check with gas utility company</li> <li>4. Refer to "24 Volt Honeywell Control Service" section</li> <li>5. Turn temperature dial to desired setting</li> <li>6. Install adequate size heater</li> <li>7. Correct piping-dip tube must be in cold inlet</li> <li>8. Advise customer</li> </ol>
BURNER FLAME LIFTS OFF PORTS	<ol style="list-style-type: none"> <li>1. High gas pressure</li> <li>2. Air contamination</li> </ol>	<ol style="list-style-type: none"> <li>1. Check the input rate with orifice size</li> <li>2. Check the combustion air quality</li> </ol>
BURNER FLAME TOO HIGH	<ol style="list-style-type: none"> <li>1. Orifice too large</li> </ol>	<ol style="list-style-type: none"> <li>1. Replace with correct orifice</li> </ol>
FLAME BURNS AT ORIFICE	<ol style="list-style-type: none"> <li>1. Defective gas control/thermostat</li> <li>2. Low gas pressure</li> <li>3. Orifice not properly installed</li> </ol>	<ol style="list-style-type: none"> <li>1. Replace gas control/thermostat</li> <li>2. Check with gas utility company</li> <li>3. Reinstall the orifice</li> </ol>

<b>PROBLEM</b>	<b>POSSIBLE CAUSE(S)</b>	<b>CORRECTION</b>
DRIP FROM RELIEF VALVE	<ol style="list-style-type: none"> <li>1. Excessive water pressure</li> <li>2. Heater stacking</li> <li>3. Closed water system</li> <li>4. Temperature setting too high</li> </ol>	<ol style="list-style-type: none"> <li>1. Use a pressure reducing valve and expansion tank</li> <li>2. Lower the thermostat setting</li> <li>3. See "Closed System/Thermal Expansion"</li> <li>4. Decrease the temperature setting</li> </ol>
INSUFFICIENT HOT WATER	<ol style="list-style-type: none"> <li>1. Thermostat set too low</li> <li>2. Hot water piping in outside wall</li> <li>3. Long runs of exposed piping</li> <li>4. Mixing valve set too low</li> </ol>	<ol style="list-style-type: none"> <li>1. Turn temperature dial to desired setting</li> <li>2. Insulate piping</li> <li>3. Insulate piping</li> <li>4. Set mixing valve to desired setting.</li> </ol>
COMBUSTION ODOURS	<ol style="list-style-type: none"> <li>1. Insufficient secondary air</li> <li>2. Flue clogged</li> <li>3. Heater installed in a confined area</li> </ol>	<ol style="list-style-type: none"> <li>1. Provide ventilation to water heater. Check flue way, flue baffle, burner</li> <li>2. Clean, locate source and correct</li> <li>3. Provide fresh air ventilation</li> </ol>
SMOKING AND CARBON FORMATION (SOOTING)	<ol style="list-style-type: none"> <li>1. Insufficient secondary air</li> <li>2. Low gas pressure</li> <li>3. Flue clogged</li> <li>4. Defective gas control/thermostat</li> <li>5. Heater installed in a confined area</li> <li>6. Burner flame yellow-lazy</li> <li>7. Finish oils on steel parts</li> </ol>	<ol style="list-style-type: none"> <li>1. Provide ventilation to water heater. Check flue way, flue baffle, burner</li> <li>2. Check with gas utility company</li> <li>3. Clean, locate source and correct</li> <li>4. Replace gas control/thermostat (37C control) Refer to "24 Volt Honeywell Control Service" section (24V control)</li> <li>5. Provide fresh air ventilation</li> <li>6. See "Burner Flame Yellow-Lazy"</li> <li>7. Smoking or smells will burn off within an hour. Open the window on start-up</li> </ol>
BURNER FLAME FLOATS	<ol style="list-style-type: none"> <li>1. Orifice too large</li> <li>2. Flue too large</li> <li>3. Flue clogged</li> <li>4. Cold drafts or cold start-ups</li> </ol>	<ol style="list-style-type: none"> <li>1. Replace with correct orifice</li> <li>2. Refer to our installation codes and size vent to the size of draft-hood</li> <li>3. Check flue and burner and clean if required</li> <li>4. Locate draft source and correct</li> </ol>
SMELLY WATER	<ol style="list-style-type: none"> <li>1. Sulfur in the water</li> </ol>	<ol style="list-style-type: none"> <li>1. Replace the anode with a special anode</li> </ol>
PILOT WILL NOT REMAIN LIT	<ol style="list-style-type: none"> <li>1. Air in gas line</li> <li>2. Defective pilot electrode</li> <li>3. Cold drafts</li> <li>4. Gas control valve ECO switch open</li> <li>5. Door mounted temperature cut-off (TCO) activated</li> <li>6. Flue damper end switch open</li> <li>7. Flammable vapours switch activated</li> <li>8. Low gas pressure</li> <li>9. Defective electrode cable/connection</li> <li>10. Improper or loose connections at the TCO switch</li> </ol>	<ol style="list-style-type: none"> <li>1. Bleed the air from the gas line</li> <li>2. Replace pilot assembly</li> <li>3. Locate source and correct</li> <li>4. Replace gas control/thermostat (37C control) Refer to "24 Volt Honeywell Control Service" section (24V control)</li> <li>5. Call a qualified service technician</li> <li>6. Replace the flue damper (24V control)</li> <li>7. Eliminate flammable vapour source. Call a qualified service technician.</li> <li>8. Check with the gas utility company.</li> <li>9. Replace or fix the cable and or connection</li> <li>10. Check the connections at the TCO switch</li> </ol>
HIGH OPERATION COSTS	<ol style="list-style-type: none"> <li>1. Thermostat set too high</li> <li>2. Sediment or lime in tank</li> <li>3. Water heater too small for job</li> <li>4. Wrong piping connections</li> <li>5. Leaking faucets</li> <li>6. Gas leaks</li> <li>7. Wasted hot water</li> <li>8. Long runs of exposed piping</li> <li>9. Hot water piping in exposed wall</li> <li>10. Leaks or cracks in dip tube</li> </ol>	<ol style="list-style-type: none"> <li>1. Set temperature dial to lower setting</li> <li>2. Drain/Flush-Provide water treatment if needed</li> <li>3. Install adequate size heater</li> <li>4. Correct piping-dip tube must be in cold inlet</li> <li>5. Repair faucets/Install thermal expansion tank</li> <li>6. Check with utility-repair at once</li> <li>7. Advise customer</li> <li>8. Insulate piping</li> <li>9. Insulate piping</li> <li>10. Check dip tube. Replace if faulty</li> </ol>

## IX) REPAIR PARTS ILLUSTRATION

1. NIPPLE-HOT OUTLET
2. NIPPLE-COLD INLET
3. DRAFTHOOD
4. TEMPERATURE & PRESSURE RELIEF VALVE
5. REDUCER RING
6. ANODE
7. DIP TUBE
8. FLUE BAFFLE
9. DRAIN VALVE
10. BURNER/MANIFOLD ASSEMBLY
11. GAS CONTROL/THERMOSTAT
12. OUTER DOOR
13. IGNITER
14. TCO SWITCH
15. FLEXIBLE MANIFOLD TUBE
16. HEAT SHIELD (60 GALLON ONLY)

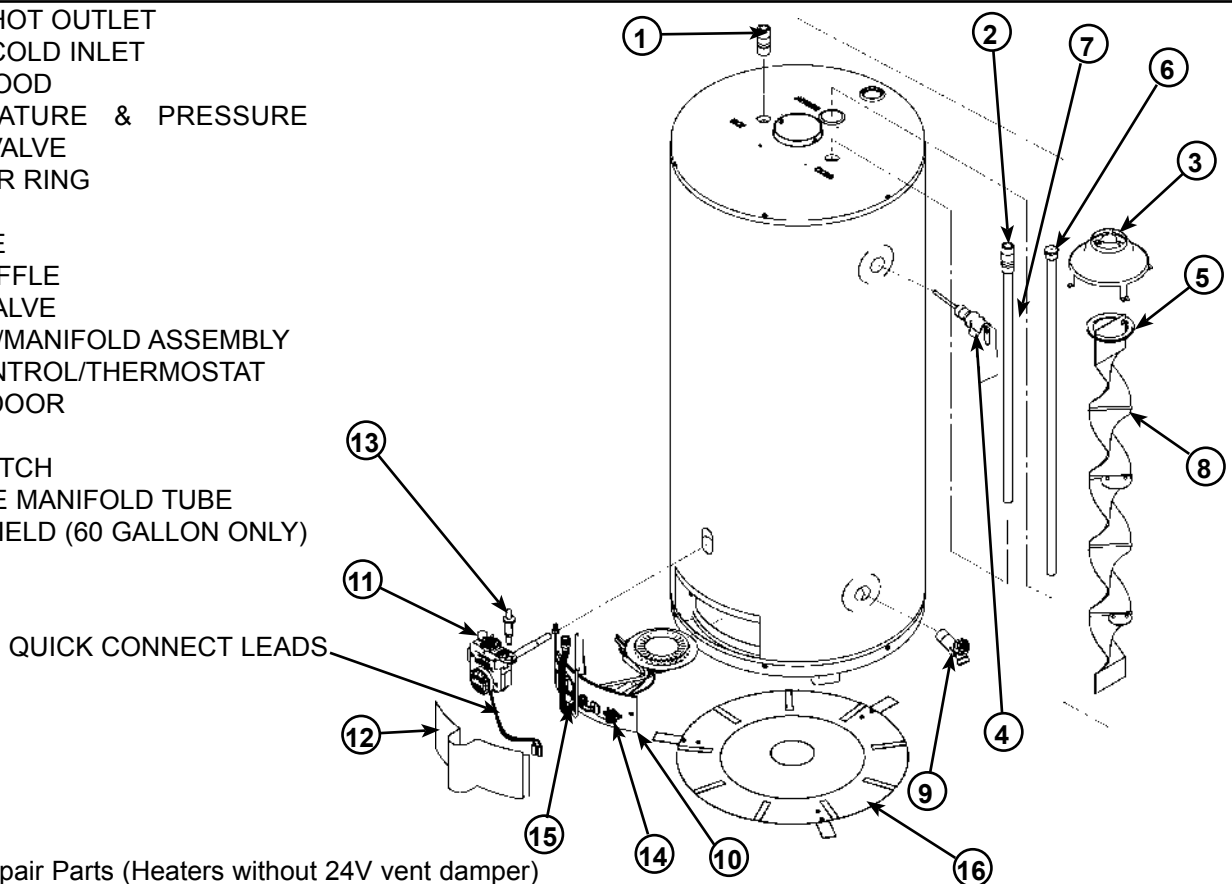

**Figure 29** Repair Parts (Heaters without 24V vent damper)

1. NIPPLE-HOT OUTLET
2. NIPPLE-COLD INLET
3. DRAFTHOOD
4. TEMPERATURE & PRESSURE RELIEF VALVE
5. REDUCER RING
6. ANODE
7. DIP TUBE
8. FLUE BAFFLE
9. DRAIN VALVE
10. BURNER/MANIFOLD ASSEMBLY
11. GAS CONTROL/THERMOSTAT
12. OUTER DOOR
14. TCO SWITCH
15. FLEXIBLE MANIFOLD TUBE
17. DAMPER

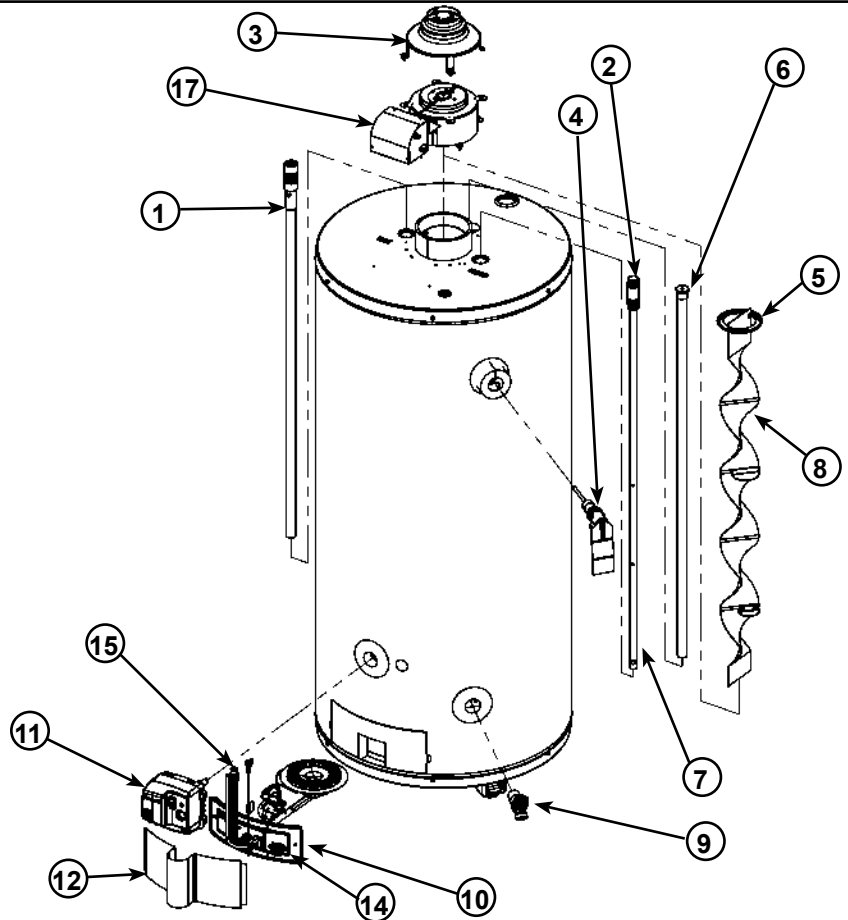

**Figure 30** Repair Parts (Heaters with 24V vent damper)

- 14. TCO SWITCH
- 17. PILOT/THERMOCOUPLE ASSEMBLY
- 18. VIEWPORT
- 19. TWO PIECE GROMMET WITH CLIP
- 20. MANIFOLD DOOR
- 21. GAS MANIFOLD
- 22. PILOT TUBE
- 23. GAS ORIFICE
- 24. MANIFOLD DOOR GASKET
- 25. BURNER

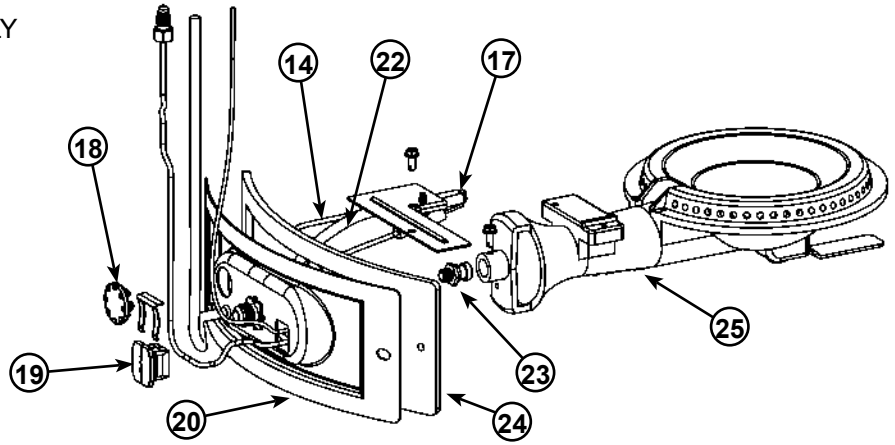

**Figure 31** Manifold/Door Assembly (LP)

- 14. TCO SWITCH
- 15. FLEXIBLE MANIFOLD TUBE
- 17. PILOT/THERMOCOUPLE ASSEMBLY
- 18. VIEWPORT
- 19. TWO PIECE GROMMET WITH CLIP
- 20. MANIFOLD DOOR
- 21. GAS MANIFOLD
- 22. PILOT TUBE
- 23. GAS ORIFICE
- 24. MANIFOLD DOOR GASKET
- 25. BURNER

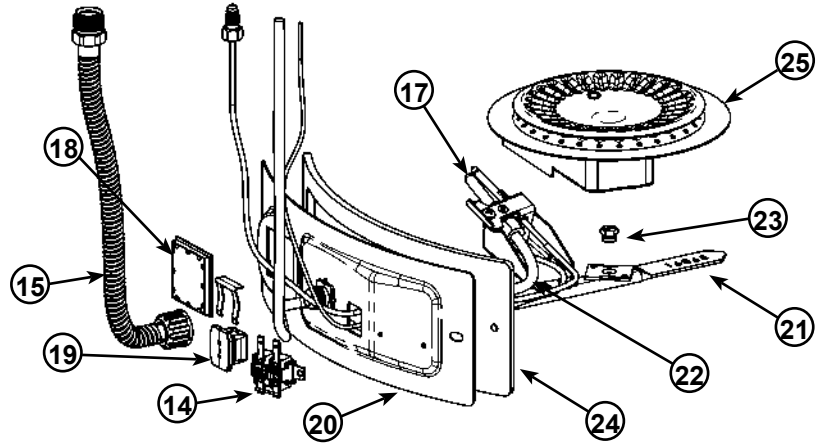

**Figure 32** Manifold/Door Assembly (NG)

- 14. TCO SWITCH
- 15. FLEXIBLE MANIFOLD TUBE
- 17. PILOT ASSEMBLY
- 18. VIEWPORT
- 19. TWO PIECE GROMMET WITH CLIP
- 20. MANIFOLD DOOR
- 21. GAS MANIFOLD
- 22. PILOT TUBE
- 23. GAS ORIFICE
- 24. MANIFOLD DOOR GASKET
- 25. BURNER

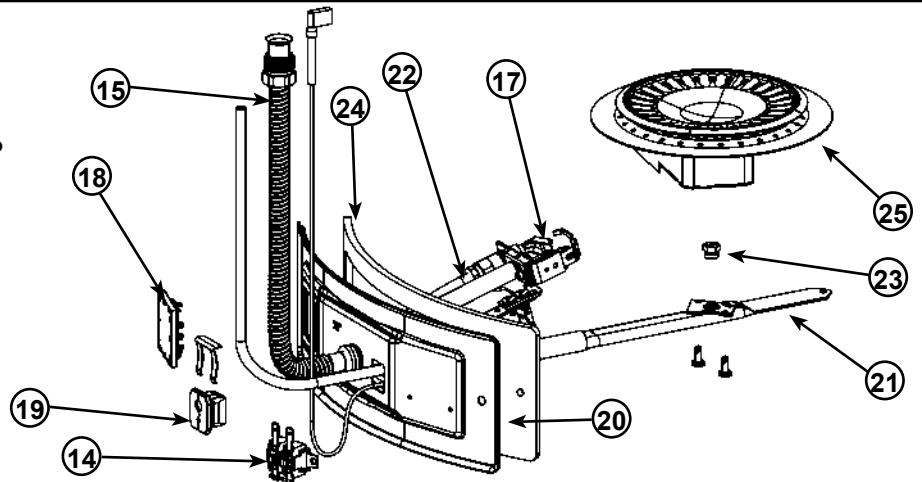

**Figure 33** Manifold/Door Assembly (24V)

This page intentionally left blank. May be used for notes or to record other installation information.

When referencing the water heater for service or warranty, please refer to the rating plate affixed to the unit for the following information:

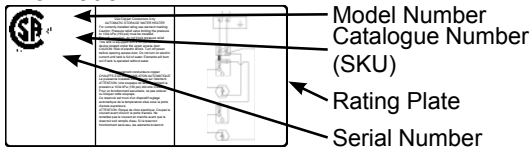

Warranty Code:	P	R	S	U	V	W	Y
Inner Tank Warranty Years:	3	5	6	8	9	10	12
Component Part Warranty Years:	1	1	1	6	1	1	1

The Serial Number contains the warranty and manufacture date information for the unit as follows:

U9999 F999999

Example: U1005 F001234

Warranty code \_\_\_\_\_  
 Year of manufacture \_\_\_\_\_  
 Week of manufacture \_\_\_\_\_

Manufactured in week 5  
 Manufactured in 2010  
 8 year tank, 6 year parts warranty

The Warranty Code indicates the inner tank and component part warranties as shown in the table above.

**LIMITED WARRANTY**

**RESIDENTIAL STORAGE TANK TYPE WATER HEATER FOR INSTALLATION IN A SINGLE FAMILY DWELLING**

**A. WHO IS COVERED.**

GSW WATER HEATING AND ITS SUPPLIERS, (herein collectively referred to as “Manufacturer”) warrants only to the original consumer purchaser (hereinafter “Owner”) of the water heater, within the boundaries of the continental United States or Canada, or their territories, so long as he or she continuously occupies the single family dwelling in which this water heater is initially installed for the period specified below. This Warranty is not transferable. This Warranty is reduced to one year if the water heater is used in a commercial or industrial application, or if the water heater is used to supply more than one dwelling unit. Consumers must retain point-of-sale proof of purchase to validate warranty entitlement.

**B. WHEN IT IS COVERED.**

The water heater is warranted only when it is installed, operated, and maintained in accordance with the printed instructions accompanying the water heater. The water heater shall/must be installed in such a manner that, if the tank or any connection thereto should leak, the resulting flow of water will not cause damage to the area in which it is installed. The water heater’s temperature and pressure relief valve must be piped to the nearest drain to avoid damage in the event the valve is actuated. For detailed instructions, read the manual accompanying the water heater and review drawings in the manual.

**C. WHAT THE MANUFACTURER WILL DO AND THE PERIOD OF COVERAGE.**

1. **The Inner Tank.** If the inner tank leaks within the warranty period shown in the table above after the original installation, the Manufacturer will furnish a new water heater of the Manufacturer’s then prevailing comparable model. If industry standards, regulatory changes, product improvements, or product obsolescence prohibits the Manufacturer from furnishing an identical model replacement water heater under this Warranty, the Owner will be furnished with a new water heater of comparable capacity; however, the Owner will be charged for the additional value of the item(s) which the Manufacturer has incorporated in the replacement water heater. A prior authorization number must be obtained from the Manufacturer before replacing the water heater. This Warranty is limited to one replacement water heater at the original installation site.
2. **Component Part.** If any component, part other than the inner tank, proves to the Manufacturer’s satisfaction to be defective in material or workmanship within the warranty period shown in the table above after the original installation, the Manufacturer will furnish the Owner with a replacement for the defective part(s). This Warranty is limited to one replacement component part for each original part.
3. **Return of Defective Water Heater and Component Parts.** The Manufacturer reserves the right to examine the alleged defect in the water heater or component part(s). As such, it will be the Owner’s obligation (see paragraph D. 3) to return the water heater and/or component part(s) to the Manufacturer.
  - a. When returning a water heater, it must include all component parts and the rating plate label.
  - b. When returning component part(s), they must be individually tagged and identified with the water heater’s Model Number, SKU, Serial Number, date of purchase, and date of installation.
  - c. THERE ARE NO WARRANTIES WHICH EXTEND BEYOND THE DESCRIPTION ON THE FACE HEREOF. THIS EXPRESS WARRANTY IS, WHERE PERMITTED BY LAW, IN LIEU OF AND EXCLUDES AND REPLACES ALL OTHER CONDITIONS, WARRANTIES, GUARANTEES, REPRESENTATIONS, OBLIGATIONS OR LIABILITIES OF THE MANUFACTURER OF ANY NATURE OR KIND, EXPRESS OR IMPLIED, HOWEVER ARISING (WHETHER BY CONTRACT, CONDUCT, STATEMENT, STATUTE, NEGLIGENCE, PRINCIPLES OF MANUFACTURER’S LIABILITY, OPERATION OF LAW, OR OTHERWISE) WITH RESPECT TO THE UNIT OR ITS FIRNESS FOR A PARTICULAR PURPOSE, METCHANTABILITY, INSTALLATION, OPERATION, REPAIR, OR REPLACEMENT. THE MANUFACTURER EXPRESSLY DISCLAIMS ANY AND ALL IMPLIED WARRANTIES. IN NO EVENT WILL THE MANUFACTURER’S LIABILITIES EXCEED THE COST OF THE DEFECTIVE PART(S) OR UNIT.

**D. WHAT THIS WARRANTY DOES NOT COVER.**

1. The Unit must not be installed where water damage can result from a leak, while provision(s) shall be made for directing any water escaping from the Unit to a properly operating drainpipe. As all units of this type may eventually leak, you must protect against any potential water damage. The Manufacturer accepts no responsibility for such damage, nor any incidental or consequential loss, nor damage(s) related thereto, suffered by the Owner of the Unit nor by any third party.
2. The Manufacturer shall not be liable under this Warranty and this Warranty shall be void and have no effect if the following events occur:
  - a. The water heater or any of its component parts have been subject to misuse, alteration, neglect, or accident; or

- b. The water heater has not been installed in accordance with the applicable local plumbing and/or building code(s) and/or regulations or, in their absence, with the latest edition of the Natural Gas and Propane Installation Code, and/or the Canadian Electrical Code; or
  - c. The water heater is not installed, operated, and maintained in accordance with the Manufacturer's instructions, including if the water heater has any additional aftermarket equipment introduced into the sealed system not approved by the Manufacturer; or
  - d. The water heater or any of its component parts are damaged or fails from operation with an empty or partially empty tank (such as, but not limited to elements burned out in a dry tank); or
  - e. The water heater or any part has been under water; or
  - f. The water heater is exposed to highly corrosive atmospheric conditions. No warranty extends, for example, and without limitation of the foregoing, to Units exposed to: salts, chemicals, exhausts, pollutants, or contaminants; or
  - g. The water heater is not continuously supplied with potable water; or
  - h. The water heater replacement is requested for reasons of noise, taste, odour, discolouration, and/or rust; or
  - i. The water heater is operated at temperatures exceeding the maximum setting of the thermostat and/or high limit control provided by the Manufacturer, or at water pressures exceeding the pressure reading stated on the Unit; or
  - j. The water heater is operated without an operating anode; or
  - k. The water heater is supplied or operated with deionized water; or
  - l. The water heater is removed from its original installation location; or
  - m. The water heater is installed outdoors (this water heater is intended only for indoor installation); or
  - n. The water heater is converted, or is attempted to be converted, from one voltage or wattage to another, if an electric water heater, or from one gas type to another, if a gas water heater; or
  - o. The water heater has not been fired at the factory rated input and fuel for which it was factory built; or
  - p. The water heater or any of its component parts fail due to sediment build-up; or
  - q. The water heater does not have installed a properly operating temperature and pressure relief valve, certified to ANSI Z21.22/CSA "Requirements for Relief Valves for Hot Water Supply Systems"; or
  - r. The water heater or any of its component parts fail because of fire, floods, lightning, or any other act of God, or any other contingency beyond the control of the Manufacturer; or
  - s. The water heater is installed in a closed system without adequate provision for thermal expansion.
3. Except when specifically prohibited by the applicable law, the Owner, and not the Manufacturer, shall be liable for and shall pay for all charges for labour or other expenses incurred in the removal, repair, or replacement of the water heater or any component part(s) claimed to be defective or any expense incurred to remedy any defect in the product. Such charges may include, but are not necessarily limited to:
- a. All freight, shipping, handling, and delivery costs of forwarding a new water heater or replacement part(s) to the Owner.
  - b. All costs necessary or incidental in removing the defective water heater or component part(s) and installing a new water heater or component part(s).
  - c. Any material required to complete and/or permits required for the installation of a new water heater or replacement part(s), and
  - d. All costs necessary or incidental in returning the defective water heater or component part(s) to a location designated by the Manufacturer.
4. The terms of this Limited Warranty cannot be modified by any person, whether or not he/she claims to represent or act on behalf of the Manufacturer.
- E. HOW THE ORIGINAL OWNER CAN MAKE A WARRANTY CLAIM.**
- 1. The Owner should submit the warranty claim direct to the Manufacturer's Service Department, at the address or phone number listed below, and the Manufacturer will arrange for the handling of the claim.
  - 2. Whenever any inquiry or request is made, be sure to include the water heater's Catalogue Number, Model Number, Serial Number, date of purchase, date of installation, and location of installation.

This Warranty and the Manufacturer's obligations shall be construed and determined in accordance with the laws of both the Province of Ontario, and of Canada in force therein. This Warranty does not affect specific legal rights of a consumer under applicable law, except to the extent that such rights may be waived or replaced, and the provisions hereof are deemed to be amended to the extent necessary. The unenforceability of any provision, in whole or in part, of this Certificate shall not affect the remaining provisions. Any and all repair and/or replacement of part(s) or Unit are the sole and exclusive remedy available against the Manufacturer.

John Wood Water Heaters  
 599 Hill Street West  
 Fergus, ON Canada N1M 2X1  
 Should you have any questions, please  
 Visit us online at [www.johnwoodwaterheaters.com](http://www.johnwoodwaterheaters.com), or  
 E-mail us at [techsupport@gsw-wh.com](mailto:techsupport@gsw-wh.com), or  
 Call our Technical Support line at 1 888 GSW TECH (479 8324)