



INSTALLATION AND OPERATING INSTRUCTIONS

Read these instructions thoroughly before starting

COMMERCIAL ELECTRIC WATER HEATER

TABLE OF CONTENTS

I) Introduction	2
II) Component Identification	3
III) Recovery Rates	4
IV) Installation	5-9
V) Electrical	10-14
VI) Operation	15
VII) Maintenance	16-18
VIII) Leakage Checkpoints	19
IX) Floor Sealing	20
Warranty	21

PLEASE RETAIN THESE INSTRUCTIONS IN A SAFE LOCATION FOR FUTURE REFERENCE



INSTALLATION RECORD

This water heater is protected by a three (3) year warranty against leaks plus a one (1) year warranty on parts. Record key data here for future reference and prompt service:

Installed By / Purchased From:		
Installation Date:	Location of Electrical Switch or Circuit Protector:	
Model Number	Serial Number	
Volts	Volume	
Watts/Element	Number of Elements	Watts-Total
Technical Support Line: 1-888-479-8324		

⚠ WARNING:

Improper installation, adjustment, alteration, service, or maintenance can cause injury or property damage. Refer to this manual. For assistance or additional information, consult a qualified installer, service agency, or the electric utility.

⚠ FOR YOUR SAFETY

- Do not store or use gasoline or other flammable vapors and liquids in the vicinity of this or any other appliance.
- Installation and service must be performed by a qualified installer, service agency or the electric utility.

⚠ WARNING:

If the information in these instructions is not followed exactly, a fire or explosion may result causing property damage, personal injury or death.



Your safety and the safety of others is very important.

We have provided many important safety messages in this manual and on your appliance. Always read and obey all safety messages.



This is the safety alert symbol.

This symbol alerts you to potential hazards that can kill or hurt you and others.

All safety messages will follow the safety alert symbol and either the word “DANGER” or “WARNING”.



DANGER You can be killed or seriously injured if you don't immediately follow instructions.



WARNING You can be killed or seriously injured if you don't follow instructions.

All safety messages will tell you what the potential hazard is, tell you how to reduce the chance of injury, and tell you what can happen if the instructions are not followed.

I) INTRODUCTION

Thank you for purchasing this water heater. Properly installed and maintained, it will provide years of trouble free service. This manual gives instructions for the proper installation, safe operation and maintenance of this water heater. It is your responsibility to ensure that your water heater is properly installed and cared for.

Important Consumer Notice

The warranty on this water heater is in effect only when the water heater is installed and operated in accordance with these instructions. The manufacturer of this water heater will not assume any liability for any injury or property damage resulting from failure to comply with these instructions.

Protect your warranty: Regularly maintain your water heater as detailed in the service and maintenance section of this manual.

Installation Code Requirements

In addition to the installation instructions found in this manual, the water heater must be installed in accordance with all local and provincial codes or, in the absence of local and provincial codes, with the latest edition of “**Canadian Electrical Code**” available from:

Canadian Standards Association
5060 Spectrum Way,
Mississauga, Ontario, Canada
L4W 5N6

The requirements of these documents must be carefully followed in all cases. Authorities having jurisdiction shall be consulted before installations are made. Check your phone listings for the local authorities having jurisdiction over your installation.

Important: All supply equipment, installation, approvals, permits, inspections, etc. are the responsibility of the owner of this water heater. Consult your local authorities for regulations specific to your area.



WARNING

THE ELECTRICAL SUPPLY TO THE WATER HEATER MUST BE TURNED OFF WHEN WORKING ON, OR NEAR, THE ELECTRICAL SYSTEM OF THE HEATER. NEVER TOUCH THE ELECTRICAL COMPONENTS WITH WET HANDS OR WHILE STANDING IN WATER. TO ENSURE CONTINUED SAFETY PROTECTION, REPLACE FUSES WITH SAME SIZE, TYPE AND RATING ONLY.

Refer to Figure 1 to identify the major components and the optional equipment installed on this water heater. Familiarize yourself with all the controls and components identified to help with checking the operation of this heater.

II) COMPONENT IDENTIFICATION

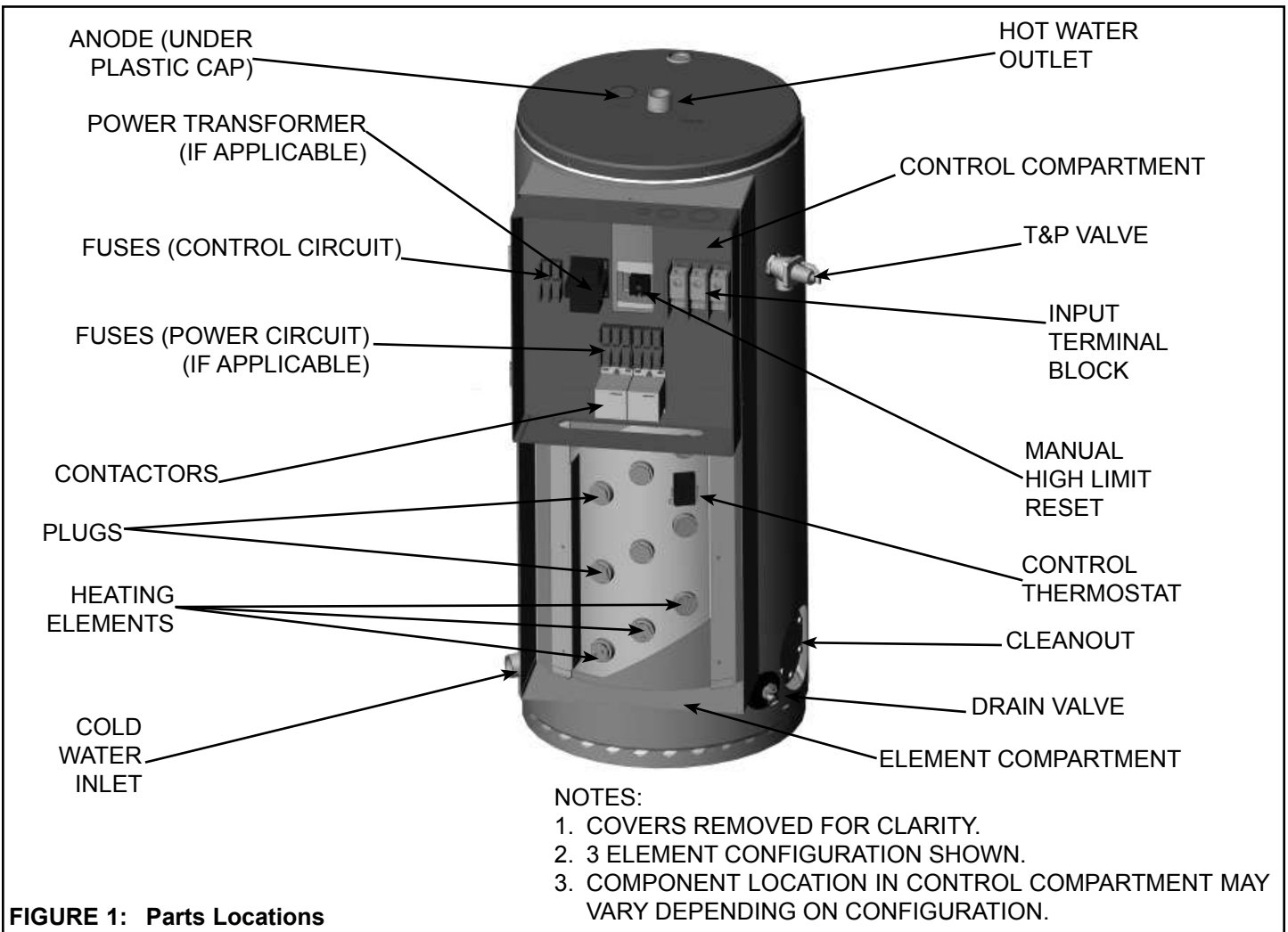

FIGURE 1: Parts Locations

III) RECOVERY RATES

RECOVERY RATE IN LITRES PER HOUR													
Standard KW Input	BTU/Hr	Temperature rise in °C											
		17°	22°	28°	33°	39°	44°	50°	56°	61°	67°	72°	78°
6	20,478	310	235	185	155	132	117	102	95	83	79	72	68
9	30,717	466	348	280	235	201	174	155	140	129	117	106	98
12	40,956	621	466	371	310	265	231	208	185	170	155	144	132
13.5	46,075	697	522	420	348	299	261	235	208	189	174	163	148
15	51,195	776	583	466	386	333	291	257	231	212	193	178	167
18	61,434	931	697	560	466	397	348	310	280	254	231	216	201
24	81,912	1242	931	746	621	530	466	413	371	337	310	288	265
27	92,151	1397	1045	837	697	598	522	466	420	382	348	322	299
30	102,390	1552	1162	931	776	666	583	519	466	424	386	360	333
36	122,868	1862	1397	1117	931	799	697	621	560	507	466	428	397
40.5	138,226	2097	1582	1257	1049	897	787	700	628	572	522	485	450
45	153,585	2328	1745	1397	1162	996	871	776	697	636	583	538	500
54	184,302	2794	2093	1677	1397	1196	1049	931	837	761	697	644	598
RECOVERY RATE IN GALLONS PER HOUR													
Standard KW Input	BTU/Hr	Temperature rise in °F											
		30°	40°	50°	60°	70°	80°	90°	100°	110°	120°	130°	140°
6	20,478	82	62	49	41	35	31	27	25	22	21	19	18
9	30,717	123	92	74	62	53	46	41	37	34	31	28	26
12	40,956	164	123	98	82	70	61	55	49	45	41	38	35
13.5	46,075	184	138	111	92	79	69	62	55	50	46	43	40
15	51,195	205	154	123	102	88	77	68	61	56	51	47	44
18	61,434	246	184	148	123	105	92	82	74	67	61	57	53
24	81,912	328	246	197	164	140	123	109	98	89	82	76	70
27	92,151	369	276	221	184	158	138	123	111	101	92	85	79
30	102,390	410	307	246	205	176	154	137	123	112	102	95	88
36	122,868	492	369	295	246	211	184	164	148	134	123	113	105
40.5	138,226	554	418	332	277	237	208	185	166	151	138	128	119
45	153,585	615	461	369	307	263	230	205	184	168	154	142	132
54	184,302	738	553	443	369	316	277	246	221	201	184	170	158

TABLE 1: Recovery Rates

IV) INSTALLATION

General

FAILURE TO FOLLOW THE INSTRUCTIONS IN THIS MANUAL MAY RESULT IN DEATH, SERIOUS BODILY INJURY AND/OR PROPERTY DAMAGE. THOROUGHLY READ ALL INSTRUCTIONS BEFORE YOU ATTEMPT TO INSTALL, OPERATE OR MAINTAIN THIS HEATER.

Location Requirements

Refer to Figure 2 to determine the size of the various models of the water heater.

1. A clear space of 457mm (18 in.) should be allowed in front of the heater to allow access to the controls and elements.
2. A clearance of 305mm (12 in.) is sufficient clearance from the top of the heater to adjacent surfaces.
3. It is suggested that the heater be located in the center of the water system or close to the point-of-use requiring the most hot water.
4. The water heater should be located in an area not subject to freezing temperatures.
5. Water heaters located in unconditioned spaces (i.e., attics, basements, etc.) may require insulation of the water piping and drain piping to protect against freezing.
6. The drain and controls must be easily accessible for operation and service.

This water heater is not intended for space heating applications.

Temperature and Pressure (T&P) Relief Valve

All water heaters must be installed with a proper temperature and pressure relief valve. This valve must be design certified by a nationally recognized testing laboratory that maintains periodic inspection of the production of listed equipment or materials as meeting the requirements for Relief Valves for Hot Water Supply Systems, CSA 4.4.

Important: Only a new temperature and pressure relief valve should be used with your water heater. Do not use an old or existing valve as it may be damaged or not adequate for the working pressure of the new water heater. Do not place any valve between the relief valve and the tank.

The T&P Valve:

- Must be connected to an adequate discharge line.
- Must not be rated higher than the working pressure shown on the data plate of the water heater.

The Discharge Line:

- Must not be smaller than the pipe size of the relief valve or have any reducing coupling installed in the discharge line.
- Must not be capped, blocked, plugged or contain any valve between the relief valve and the end of the discharge line.
- Must terminate a maximum of 300mm (12 in.) above a floor drain or external to the building.

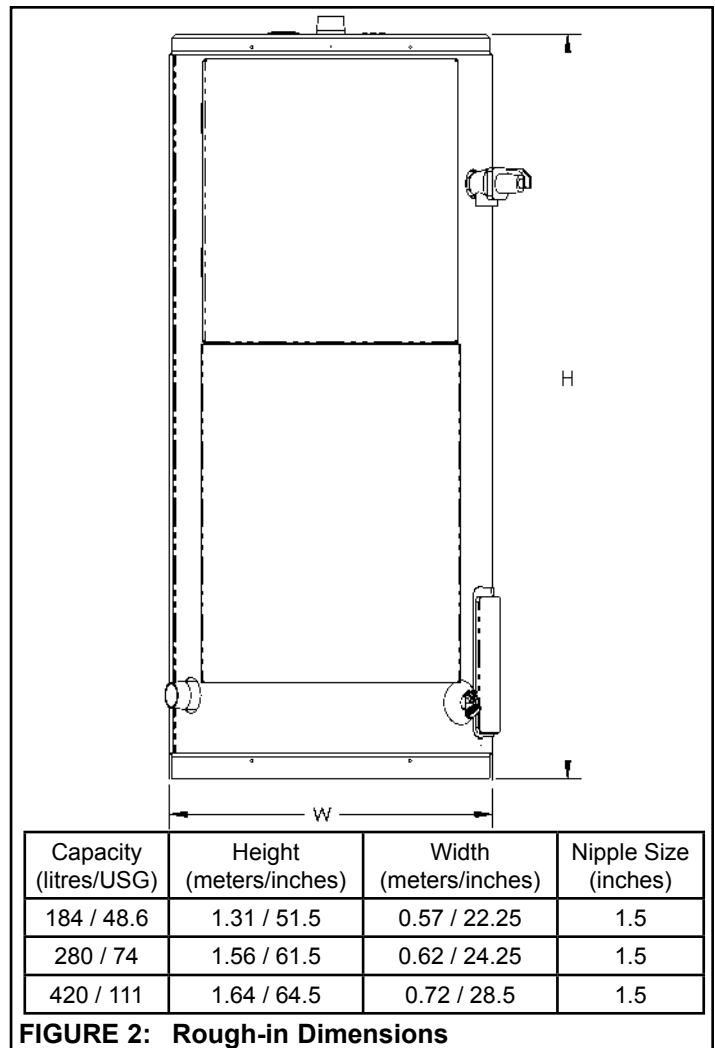

FIGURE 2: Rough-in Dimensions

- Must be capable of withstanding 121°C (250°F) without distortion.
- Must be installed to allow complete drainage of both the valve and discharge line.
- Must not discharge so as to come in contact with any electrical part or wiring.

Under no circumstances is the manufacturer to be held responsible for any water damage in connection with this water heater.

IMPORTANT:

This water heater must be installed strictly in accordance with the instructions enclosed, and local electrical, fuel and building codes. It is possible that connections to the water heater, or the water heater itself, may develop leaks. IT IS THEREFORE IMPERATIVE that the water heater be installed so that any leakage of the tank or related water piping is directed to an adequate drain in such a manner that it cannot damage the building, furniture, floor covering, adjacent areas, lower floors of the structure or other property subject to water damage. This is particularly important if the water heater is installed in a multi-story building, on finished flooring or carpeted surfaces. GSW WILL NOT ASSUME ANY LIABILITY for damage caused by water leaking from the water heater, pressure relief valve, or related fittings. Select a location as centralized within the piping system as possible. In any location selected, it is recommended that a suitable drain pan be installed under the water heater. This pan must limit the water level to a MAXIMUM depth of 45mm (1 3/4 in.) and have a diameter that is a minimum of 50mm (2 in.) greater than the diameter of the water heater. Suitable piping shall connect the drain pan to a properly operating floor drain.

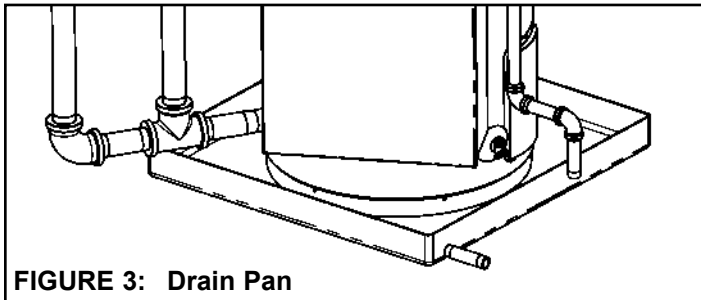

FIGURE 3: Drain Pan

WARNING!

Closets without drains and carpeted areas are examples of unsuitable locations for any water heater. Select a location as centralized within the piping system as possible. The heater should be located in an area not subject to freezing temperatures. If this heater is to be installed directly on carpeting, the carpeting must be protected by a metal or wood panel beneath the heater, extending beyond the full width and depth of the heater by a minimum 80mm (3 in.). If the heater is installed in a closet or alcove, the entire floor must be covered by the panel. This panel must be strong enough to support the weight of the heater full of water without breaking. Failure to heed this warning may result in a fire hazard.

Closed System/Thermal Expansion

Water supply systems may, because of code requirements or such conditions as high line pressure, among others, have installed devices such as pressure reducing valves, check valves, and back flow preventers. Devices such as these cause the water system to be a closed system. As water is heated, it expands (thermal expansion). In a closed system the volume of water will grow when it is heated. As the volume of water grows there will be a corresponding increase in water pressure due to thermal expansion. Thermal expansion can cause premature tank failure (leakage). This type of failure is not covered under the limited warranty. Thermal expansion can also cause intermittent Temperature-Pressure Relief Valve operation: water discharged from the valve due to excessive pressure buildup. This condition is not covered under the limited warranty. The Temperature-Pressure Relief Valve is not intended for the constant relief of thermal expansion. A properly sized thermal expansion tank must be installed on all closed systems to control the harmful effects of thermal expansion. Contact a local plumbing service agency to have a thermal expansion tank installed. NEVER PLUG OR REMOVE the T&P valve.

Important: Do not plug or remove the temperature and pressure relief valve.



WARNING

Excessive Weight Hazard

Use two or more people to move and install water heater.

Failure to do so can result in back or other injury.

Unpacking the Water Heater

Important: Do not remove any permanent instructions, labels, or the data label from the outside of the water heater or on the inside of panels. Remove exterior packaging and place installation components aside. Inspect all parts for damage prior to installation and start-up. Completely read and understand all instructions before attempting to assemble and install this product. After installation, dispose of packaging material in the proper manner.

Important: Strictly follow the installation instructions before making electrical connections.

Piping Installation

Piping, fittings, and valves should be installed according to the installation drawing (Figure 4). If the indoor installation area is subject to freezing temperatures, the water piping must be protected by insulation. Water supply pressure should not exceed 80% of the working pressure stated on the water heater's data plate. If the supply pressure is higher than this limit, a pressure limiting valve with a bypass must be installed in the cold water inlet line. This should be placed on the supply to the entire building in order to maintain equal hot and cold water pressures.

Important: Heat must not be applied to the water fittings on the heater as they may contain nonmetallic parts. If solder connections are used, solder the pipe to the adaptor before attaching the adaptor to the hot and cold water fittings.

Important: Always use a good grade of joint compound that is compatible with potable water and be certain that all fittings are drawn up tight.

1. Install the water piping and fittings as shown in Figure 4. Connect the cold water supply (1 1/2 in. NPT) to the fitting marked "Cold Water Inlet". Connect the hot water supply (1 1/2 in. NPT) to the fitting marked "Hot Water Outlet".
Important: Arrow on inlet fitting should remain at the 12 o'clock position.
2. The installation of unions in both the hot and cold water supply lines is recommended for ease of removing the water heater for service or replacement.
3. The manufacturer of this water heater recommends installing a tempering valve in the domestic hot water line as shown in Figure 4. These valves reduce the point-of-use temperature of the water by mixing cold and hot water and are readily available for use. Contact a licensed plumber or the local plumbing supplier.
4. If installing the water heater in a closed water system, install an expansion tank in the cold water line as specified under "Closed System/Thermal Expansion".
5. Install a shut-off valve in the cold water inlet line. It should be located close to the water heater and be easily accessible. Show the user the location of this valve and how use it to shut off the water to the heater.
6. A temperature and pressure relief valve is installed in the opening marked "Temperature and Pressure (T&P) Relief Valve" on the water heater. Add a discharge line to the opening of the T&P relief valve. Follow the instructions under "Temperature and Pressure (T&P) Relief Valve".

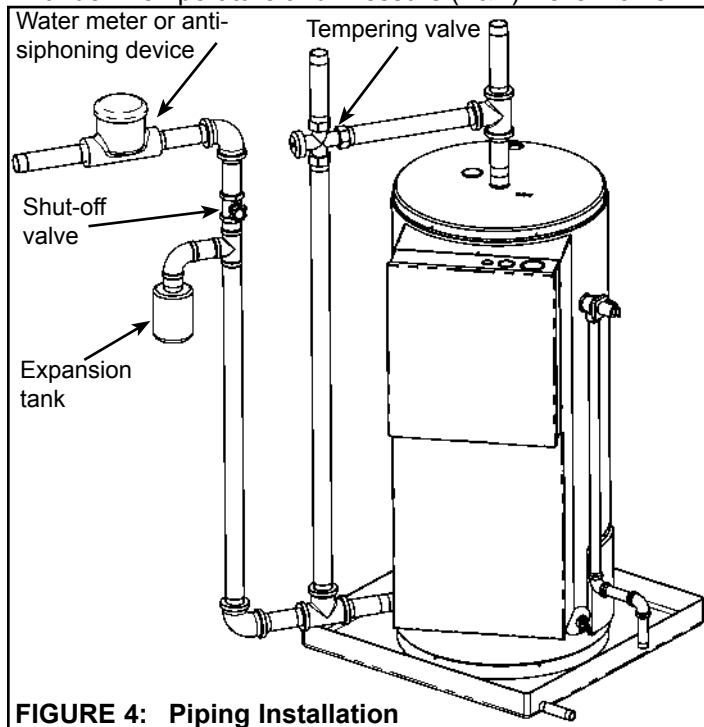

FIGURE 4: Piping Installation

7. After piping has been properly connected to the water heater, close the shut-off valve in the cold water inlet line.

Please note the following:

DO NOT install this water heater with iron piping. The system should be installed only with piping that is suitable for potable (drinkable) water such as copper, CPVC, or polybutylene. **DO NOT** use PVC water piping.

DO NOT use any pumps, valves, or fittings that are not compatible with potable water.

DO NOT use valves that may cause excessive restriction to water flow. Use full flow ball or gate valves only.

DO NOT use 50/50 tin-lead solder (or any lead based solder) in potable water lines. Use 95/5 tin-antimony or other equivalent material.

DO NOT tamper with the temperature and pressure relief valve. Tampering voids all warranties. Only qualified service technicians should service these components.

DO NOT use with piping that has been treated with chromates, boiler seal, or other chemicals.

DO NOT add any chemicals to the system piping that will contaminate the potable water supply.

DO NOT apply electrical power before the tank is filled with water and you have confirmed that there are no leaks in the piping and connections.

⚠ WARNING

TO REDUCE RISK OF ELECTRIC SHOCK OR POSSIBLE ELECTROCUTION THE WATER HEATER MUST BE ELECTRICALLY GROUNDED. The electrical supply to the water heater should be a separately grounded branch circuit having overcurrent protection and a disconnect switch. Refer to the rating plate attached to the heater to determine the correct ratings for voltage and amperage. To ensure proper operation, the supply voltage should be within +5% and -10% of the rated voltage of the heater. The water heater should be grounded in accordance with national and local codes.

⚠ WARNING

WATER HEATER EQUIPPED FOR LIMITED VOLTAGE RANGE. This water heater is designed to operate within a specific voltage range. Check rating plate mounted on the heater for the correct voltage. DO NOT connect this water heater to any voltage supply other than that indicated on the rating plate. Failure to use the correct voltage may result in unsafe operation and personal injury or property damage. If you have any questions or doubts consult your electric company.

Electrical Connections

CAUTION! TO PREVENT DAMAGE TO THE TANK AND HEATING ELEMENT(S), THE TANK MUST BE FILLED WITH WATER BEFORE TURNING "ON" POWER. SEE "FILLING THE WATER HEATER".

The information in Table 3 may be used as a guide to determine the wire size of the branch circuit. It is recommended the branch circuit wiring be 125% of the amperage rating of the water heater. If the heater is located a long distance away from the electrical supply, the wire size of the branch circuit should be increased. The voltage measured at the heater should not be less than 3% lower than what is measured at the supply. If your calculated value does not appear in the table, substitute the next highest rating listed in the table.

1. Ensure the element marking and rating plate data correspond with the electric service available.
2. Install a branch circuit directly from the main service panel to the water heater. The wiring of this circuit must be of adequate size for the length of run and the load (see Table 3).
3. A ground wire must run from the green ground screw provided at the electrical connection point in the heater junction box to the ground connection at the service panel.
4. Final connections are made in the control panel box on the heater.
5. The heater you have received is internally wired. A specific wiring diagram for each heater is located inside the control panel. All internal wiring is colour-coded and connections must be made as shown in the wiring diagrams (Figures 5-10).

Installation Check List

- | | Check Here |
|---|--------------------------|
| 1. Are the fuse and wire sizes correct? | <input type="checkbox"/> |
| 2. Is the certified relief valve installed? | <input type="checkbox"/> |
| 3. Were steps taken to prevent water damage in case of leaks? | <input type="checkbox"/> |
| 4. Has the relief valve been piped to a suitable drain point? | <input type="checkbox"/> |
| 5. Is the relief valve discharge unobstructed? | <input type="checkbox"/> |
| 6. Is the heater completely filled with water? | <input type="checkbox"/> |
| 7. Is the cold water supply valve open? | <input type="checkbox"/> |
| 8. Provision made for thermal expansion? | <input type="checkbox"/> |

If the answer to the above are yes, turn on the power and enjoy all the hot water you need, all the time.

Temperature Control

All electric water heaters feature fully automatic controls to regulate the water temperature. The thermostat supplied with the water heater may be either an immersion or a surface mounted type. Both types of thermostats use contact relays to energize the electric heating elements. The thermostats are located in the bottom control panel. The thermostats are factory set to 60°C (140°F) to reduce the risk of scalding. Water temperature adjustments for the immersion type thermostat can be made by turning the temperature adjustment dial, located on the outside of the lower control panel, to the desired temperature setting. Water temperature adjustments can be made to the surface mounted thermostat by first turning off the electric power supply to the water heater and removing the bottom control panel cover. Using a screwdriver, turn the thermostat dial to the desired temperature setting. The water heater is equipped with a surface mounted high limit control located under insulating material in the top control panel. If for any reason the water temperature becomes excessive, the high limit will de-energize the heating element circuit. Once the high limit has been activated it must be manually reset by pushing in the red reset button located on the high limit. The cause of the excessive temperature should be determined and corrected.

WARNING

Hot water produced by this appliance can cause severe burns due to scalding. The hazard is increased for young children, the aged, or the disabled where water temperatures exceed 52°C (125°F). Use tempering valves in the hot water system to reduce the risk of scalding at point-of-use such as lavatories, sinks and bathing facilities. Such precautions must be followed when this heater is operated in combination with dishwashing or space heating applications.

WARNING

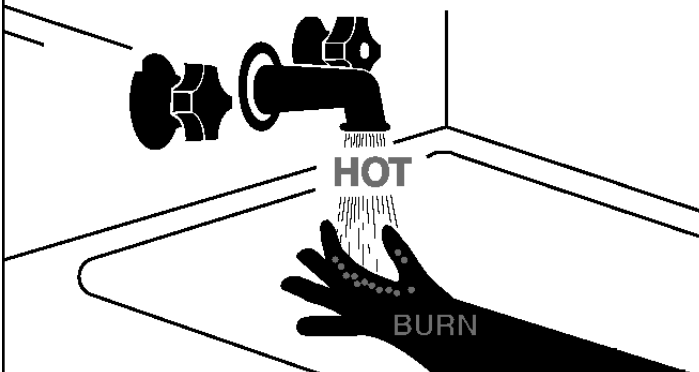

Water temperature over 52°C (125°F) can cause severe burns instantly or death from scalds.

Children, disabled and elderly are at highest risk of being scalded.

Feel water before bathing or showering. Temperature limiting valves are recommended.

CAUTION

Hydrogen gas can be produced in a hot water system served by this heater that has not been used for a long period of time (generally two (2) weeks or more). **Hydrogen gas is extremely flammable and can ignite when exposed to a spark or flame.** To reduce the risk of injury under these conditions, it is recommended that the hot water faucet be opened for several minutes at the kitchen sink before using any electrical appliance connected to the hot water system. Use caution in opening faucets. When hydrogen is present, there will probably be an unusual sound such as air escaping through the pipe as the water begins to flow. There should be no smoking or open flame near the faucet at the time it is open.

Water Heater Sounds

During the normal operation of the water heater, sounds or noises may be heard. These noises are common and may result from the following:

1. Normal expansion and contraction of metal parts during the periods of heat-up and cool-down.
2. Sediment build up in the tank bottom will create varying amounts of noise and may cause premature tank failure. Drain and flush the tank as directed under "Draining, Flushing and Sediment Removal".

V) ELECTRICAL

KW Input	No. of Elements	Element Wattage	Full Load in Amperes					
			Single Phase			Three Phase		
			208V	240V	600V	208V	240V	600V
6	3	2000	28.8	25.0	10.0	16.7	14.4	5.8
9		3000	43.3	37.5	15.0	25.0	21.7	8.7
12		4000	57.7	50.0	20.0	33.3	28.9	11.5
13.5		4500	64.9	56.3	22.5	37.5	32.5	13.0
15		5000	72.1	62.5	25.0	41.6	36.1	14.4
18		6000	86.5	75.0	30.0	50.0	43.3	17.3
18	6	3000	86.5	75.0	30.0	50.0	43.0	17.3
24		4000	115.4	100.0	40.0	66.6	57.7	23.1
27		4500	129.8	112.5	45.0	74.9	65.0	26.0
30		5000	144.2	125.0	50.0	83.3	72.2	28.9
36		6000	173.1	150.0	60.0	99.9	86.6	34.6
36	9	4000	173.1	150.0	60.0	99.9	86.6	34.6
40.5		4500	194.7	168.8	67.5	112.4	97.4	39.0
45		5000	216.3	187.5	75.0	124.9	108.3	43.3
54		6000	N/A	225.0	90.0	150.0	129.9	52.0

TABLE 2: Load Currents

KW Input	No. of Elements	Element Wattage	Minimum Field Wiring Size, AWG, 75°C					
			Single Phase			Three Phase		
			208V	240V	600V	208V	240V	600V
6	3	2000	10	10	14	12	12	14
9		3000	8	8	14	10	10	14
12		4000	6	6	12	8	10	14
13.5		4500	6	6	10	8	8	14
15		5000	4	6	10	8	8	14
18		6000	3	4	10	6	8	12
18	6	3000	3	4	10	6	8	12
24		4000	2	3	8	4	6	10
27		4500	1	2	8	4	6	10
30		5000	0	1	6	4	4	10
36		6000	00	0	6	3	3	8
36	9	4000	00	0	6	3	3	8
40.5		4500	000	00	4	2	3	8
45		5000	0000	000	4	1	2	8
54		6000	N/A	0000	3	0	1	6

TABLE 3: Wiring Requirements

Note: Table 3 is for reference only.

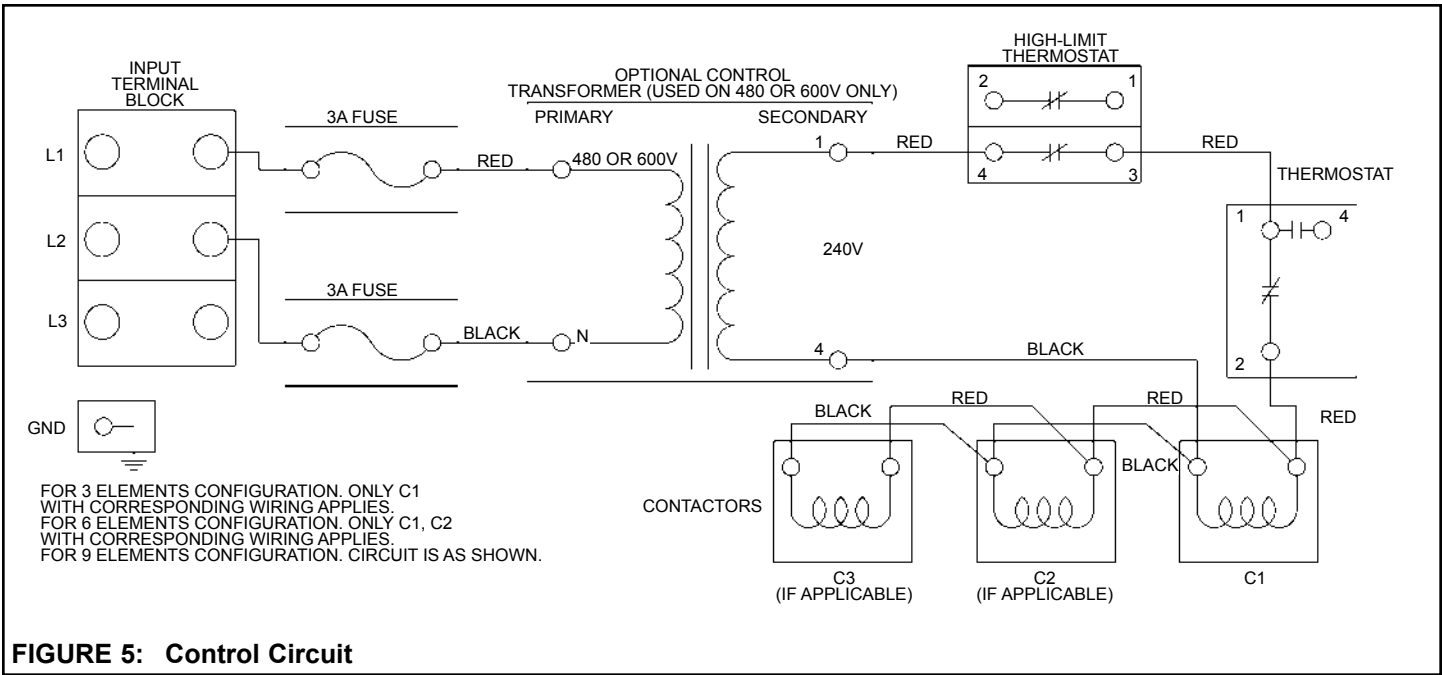

FIGURE 5: Control Circuit

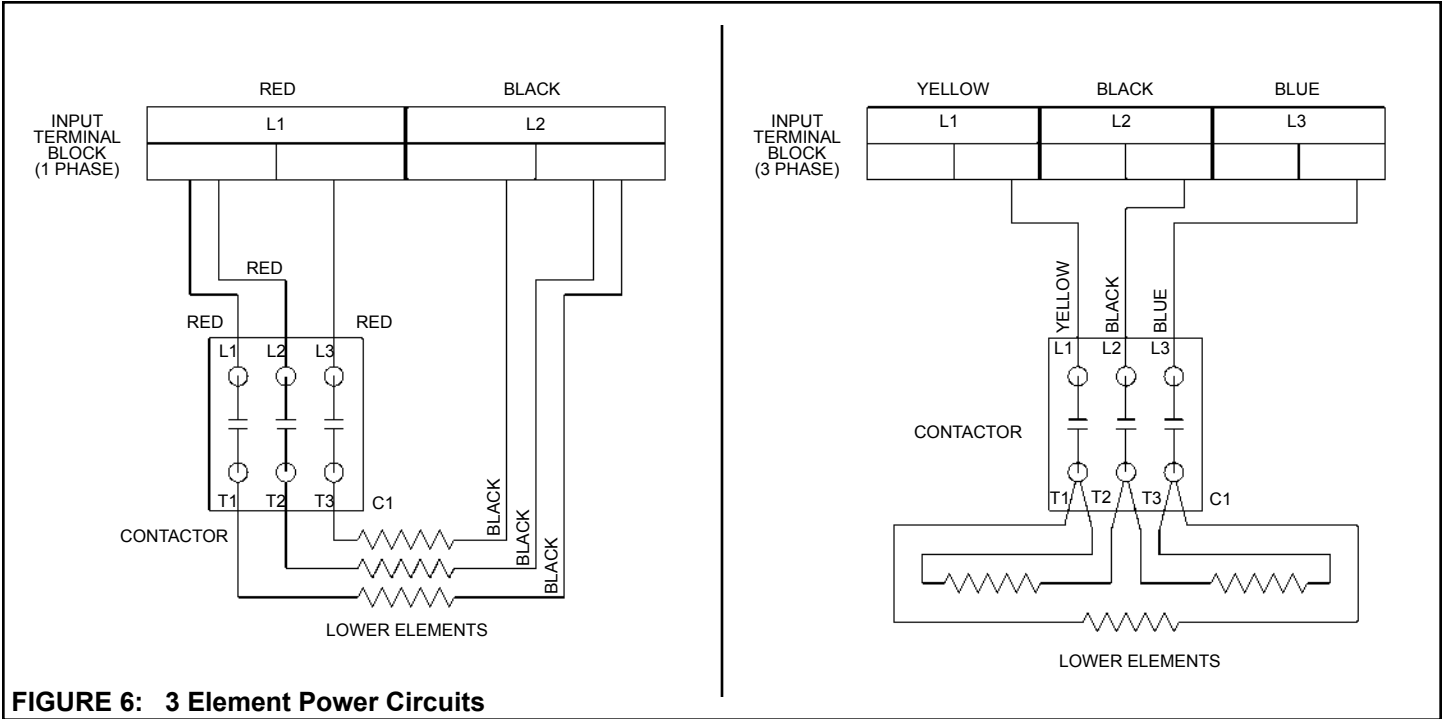

FIGURE 6: 3 Element Power Circuits

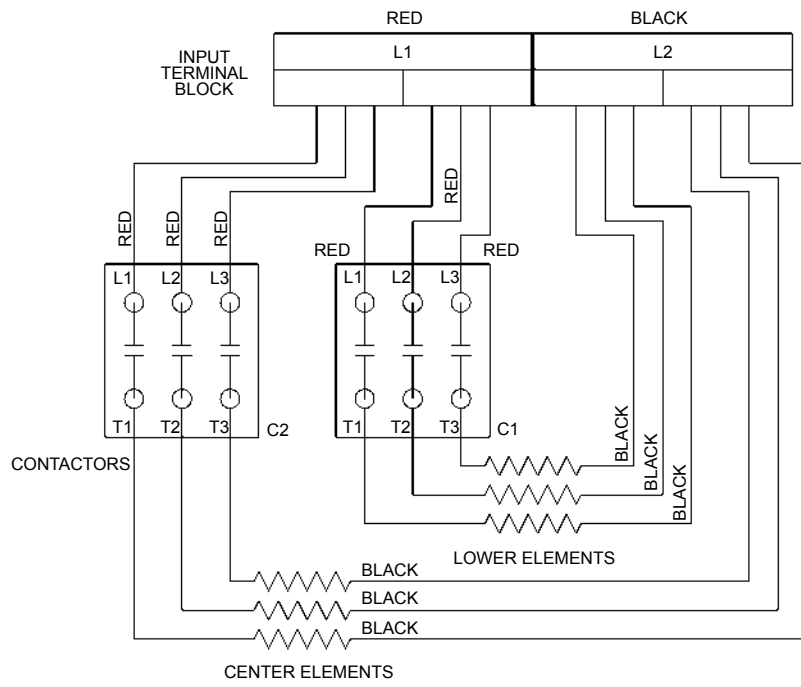

FIGURE 7: 6 Element, 1 Phase Power Circuit

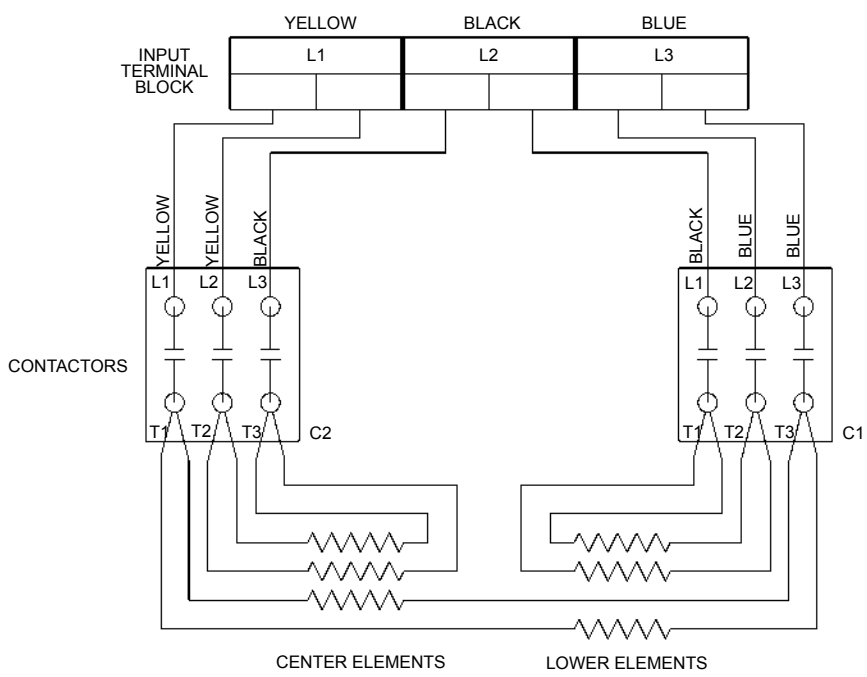

FIGURE 8: 6 Element, 3 Phase Power Circuit

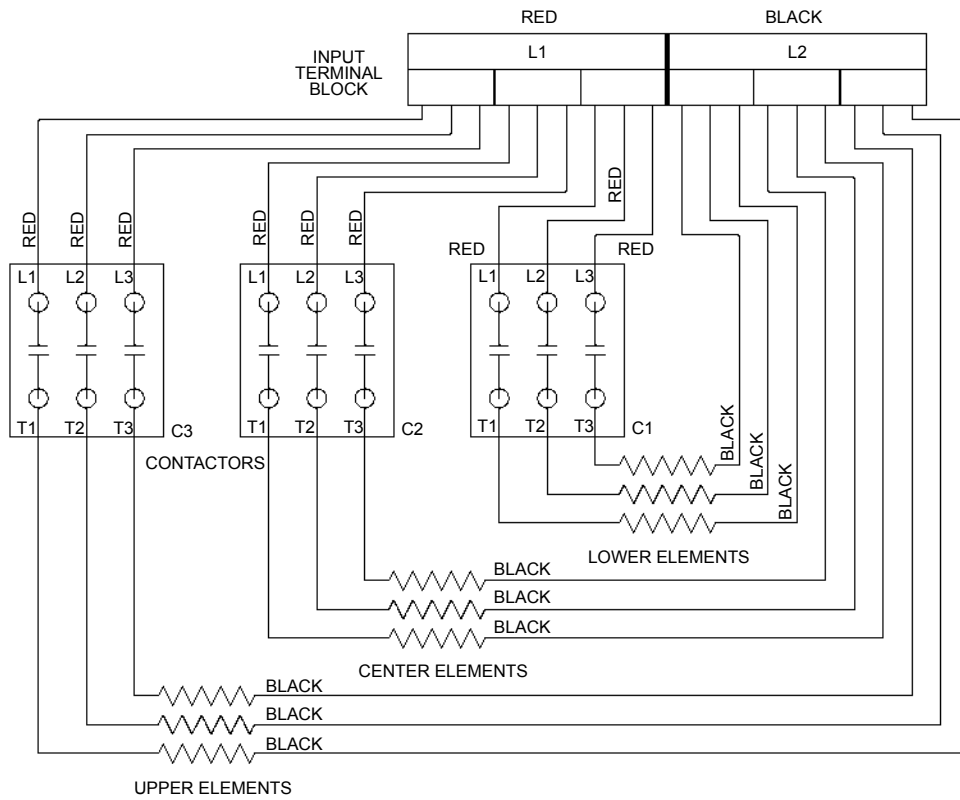

FIGURE 9: 9 Element, 1 Phase Power Circuit

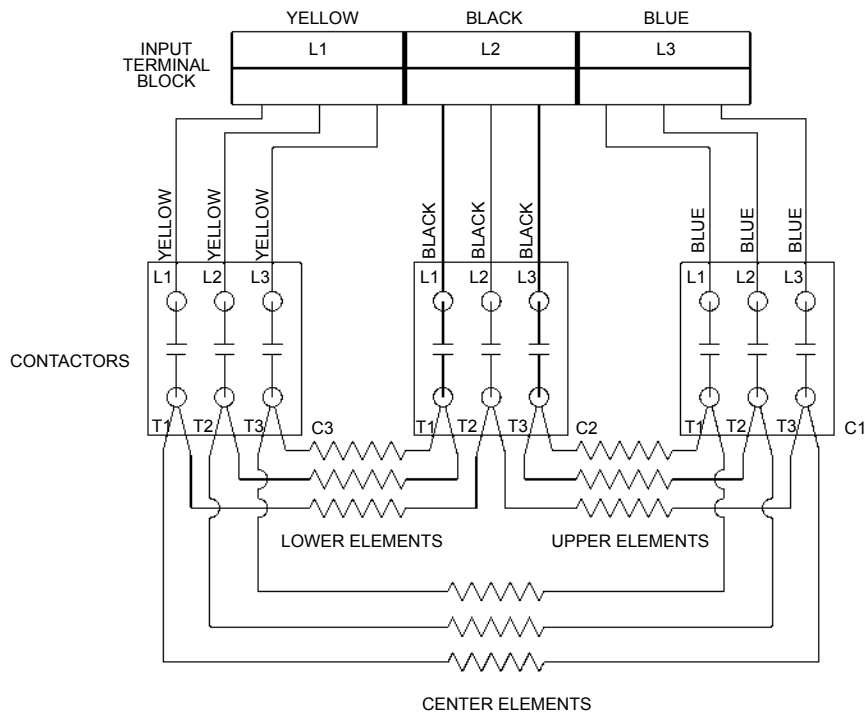

FIGURE 10: 9 Element, 3 Phase Power Circuit

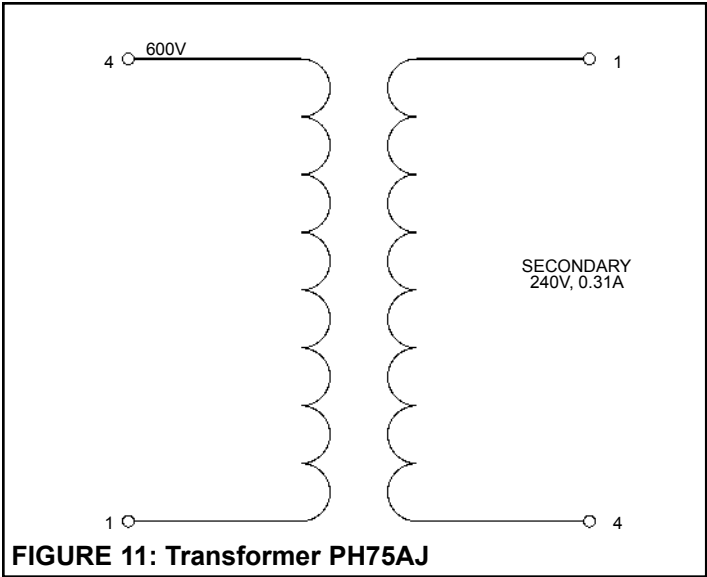

FIGURE 11: Transformer PH75AJ

VI) OPERATION

General

CAUTION! NEVER APPLY ELECTRICAL POWER TO THIS WATER HEATER UNLESS IT IS COMPLETELY FULL OF WATER. TO PREVENT DAMAGE TO THE TANK AND HEATING ELEMENTS, THE TANK MUST BE FILLED WITH WATER BEFORE USE. WATER MUST FLOW FROM THE HOT WATER FAUCET BEFORE APPLYING POWER.

Filling the Water Heater

1. Do not turn the power on until all the following steps, including Startup steps, have been completed.
2. Make sure the drain valve is closed.
3. Open a hot water faucet associated with the system.
4. Open the cold water supply valve.

NOTE: When filling, avoid water leakage. Do not allow the insulation of the water heater to get wet as water can cause electrical malfunction.

5. When water runs out of the hot water faucet in a steady stream, the tank is full.
6. Close the hot water faucet and check the system for leaks. Repair as required and retest.
7. Connect a hose to the drain valve and route to a suitable drain. Open the drain valve and let water run to flush out any foreign matter that may have entered the system. Once flushed, close the drain valve and disconnect hose. Repeat steps 4-6.

Startup

Perform the following checks when the heater is placed into operation for the first time.

Voltage Check: Verify that the supply voltage and the rating plate voltage are the same.

1. Open the upper component panel cover and check all electrical connections.
2. Remove the lower cover and the insulation for the element compartment and check all electrical connections.
3. Turn "ON" the electrical supply to the heater.
4. Carefully watch all the components for one complete cycle of operation to see that they function properly.

DANGER: Hazardous voltages are present in both compartments. Be careful not to touch any electrical connections.

5. To check the operation of the thermostat
 - (a) operate the thermostat manually and
 - (b) let the heater come to the preset temperature and shut off automatically.
6. Turn "OFF" the electrical supply to the heater.
7. Replace all the insulation and close all covers.
8. Turn "ON" the electrical supply to the heater.

High Temperature Limiting Device

The heater is equipped with a high temperature cutoff switch. If the water temperature exceeds the preset limit this device turns off the power to the heating elements. The high temperature switch is set to activate at 88°C (190°F). If the switch has been activated, allow the water temperature to drop by 17°C (30°F) (min) and reset manually. The high-temperature switch is not adjustable.

VII) MAINTENANCE

General

Do not attempt to repair water heater. Call your authorized dealer for service. Shut off the electric power whenever the water supply is turned off. Before calling for service, check that:

1. The heater is properly filled.
2. The electrical supply has not been interrupted.

Draining, Flushing and Sediment Removal

Water may contain fine particles of soil and sand which settle to the bottom of a tank and thus form a layer of sediment. If not removed, the sediment could reach the heating elements and cause them to fail. It is recommended that the tank be drained and flushed on a regular basis to remove any sediment that may buildup during operation. Some maintenance and service procedures require that the heater be drained and empty. The water heater should also be drained if being shut down for an extended period of time. To drain and remove the sediment from the tank:

1. Turn the electrical supply to the heater "OFF".
2. Close the cold water supply valve.
3. Attach hose to the drain valve and route to an adequate drain.

CAUTION! The water being drained can be extremely hot!

The drain hose should be rated for at least 93°C (200°F). If the drain hose does not have this rating, open the cold water supply valve and a nearby hot water faucet served by the system until the water flow is no longer hot. Close the cold water supply valve and resume.

4. Open the drain valve using a flat-blade screwdriver. A nearby hot water faucet must be opened to allow the tank to be fully drained.
5. Open the cold water supply valve and flush the tank as needed to remove sediment and any other foreign matter that may have entered the system. Close the cold water supply valve when clean water flows.
6. If the heater is to remain empty for an extended period of time, it is suggested the drain valve be left open. When draining is complete, the hose may be removed.
7. Perform any other servicing as required.
8. Close the drain valve, disconnect hose.
9. Follow instructions for "Filling the Water Heater" and "Startup" when heater is ready to be put back into service.

NOTE: If the water heater is going to be shut down for an extended period, drain the tank as directed in "Draining, Flushing and Sediment Removal". Ensure that the cold water supply valve is closed and the drain valve left open.

Temperature and Pressure (T&P) Relief Valve Check

CAUTION! THE WATER COMING FROM THE VALVE MAY BE EXTREMELY HOT.

Manually operate the temperature and pressure relief valve at least once a year to make sure it is working properly. To

prevent water damage, the valve must be properly connected to a discharge line which terminates at an adequate drain. Stand clear of the outlet (discharged water may be hot) and slowly lift and release the lever handle on the temperature and pressure relief valve (see Figure 12) to allow the valve to operate freely and return to its closed position. If the valve fails to completely reset and continues to release water, immediately turn "OFF" the power and close the cold water inlet and call a qualified service technician.

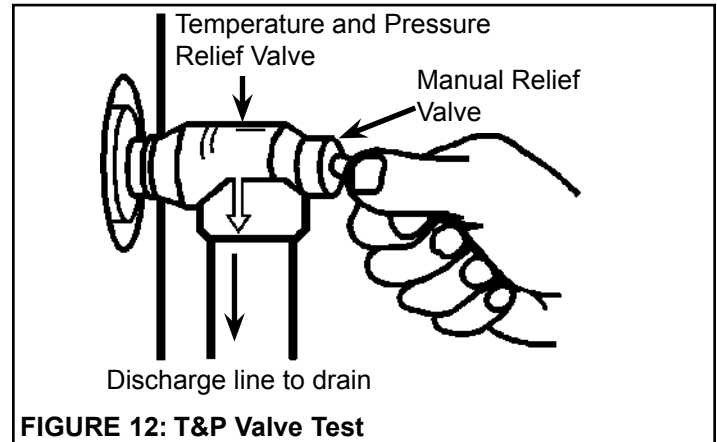

FIGURE 12: T&P Valve Test

Cathodic Protection

Your water heater has been equipped with one or more anodes that protect the glass-lined tank from corrosion and prolong the life of the water heater. Over time, as the anode(s) works, it slowly dissolves, exposing the steel inner core. Once the anode(s) is depleted, the tank will start to corrode, eventually developing a leak. Depending on water conditions, an anode(s) can last from one to ten years. Many localities treat their water and this can have a significant effect on the life of your heater. Water conditioning, such as over-softening, can accelerate the rate at which the anode(s) is consumed. As with any water heater, it is good practice to check the anode(s) annually to see if it needs replacing. Do not remove this anode(s) permanently as it will void any warranties, stated or implied. Rapid depletion or failure to maintain the anode can leave a heater unprotected and may result in premature failure of the heater due to corrosion and leaks.

Hot Water Odour

On occasion, and depending on your location, hot water may develop a strong odour. This can be especially problematic in regions where the water contains sulphur, which results in hot water having a "rotten egg" odour. If this occurs, drain the system completely, flush thoroughly and refill the tank. If the water odour or discoloration persists, the anode(s) may need to be changed from magnesium to one made of aluminum. Aluminum anodes may reduce, but not eliminate, water odour problems. The water supply system may require special filtration equipment from a water conditioning company to successfully eliminate all water odour problems. In certain cases chlorinating and flushing of the water heater may be required. Contact your dealer or water supplier.

Discoloured Water

- Water rich in iron or other minerals can produce red or brown staining. Heating water generally worsens this situation.
- Black water can be an indication of organic contaminants in the water supply. This can be problematic in areas where the water is obtained from surface or contaminated sources. Organic particles can develop bacterial growth, causing potential health hazards.
- Contact your water supplier for proper filtration or water conditioning equipment.
- For bacterial problems contact your local health authority. See also “Hot Water Odour”.
- A sudden appearance of rust-coloured water may indicate that the anode(s) has been depleted. Once depleted, the anode’s inner steel core becomes exposed causing it to corrode and release iron particles into the water. See also “Anode Maintenance”.

Anode Maintenance

A new anode is about 20mm (13/16 in.) to 22mm (7/8 in.) diameter and has a steel wire core approximately 3mm (1/8 in.) diameter in the center. The anode should be replaced when this wire is visible. Operating a water heater without an actively working anode(s) will void the warranty.

To check/replace the anode:

1. Turn "OFF" the electrical supply to the water heater.
2. Close the cold water supply valve.
3. Open a nearby hot water faucet served by the system to depressurize the system.
4. Connect a hose to the drain valve and drain 22 litres (6 USG.) as directed in “Draining, Flushing and Sediment Removal”.

CAUTION! The water being drained can be extremely hot!

The drain hose should be rated for at least 94°C (200°F). If the drain hose does not have this rating, open the cold water supply valve and a nearby hot water faucet served by the system until the water flow is no longer hot. Close the cold water supply valve and resume.

5. Using a 1 5/16" socket, remove the anode(s) and inspect it. The surface may be rough, full of pits and crevices, but this is normal. If it is less than approximately 10mm (3/8 in.) in diameter, or the inner steel core exposed, the anode(s) should be replaced.

NOTE: The anode(s) has been factory installed using a power tool. It may be necessary for a second person to stabilize the heater. A few sharp blows on the handle of the socket wrench should loosen the anode nut. If an impact wrench (power drive) is available, this is an easier way to remove an anode.

6. Apply Teflon® tape or sealing compounds approved for use with potable water to the threads of the anode(s) and install into the tank top.
7. Open the cold water supply valve and open a nearby hot water faucet to purge air from the water tank as directed in “Filling the Water Heater”.
8. Check for leaks, repair as required, and re-test.
9. Turn the electrical supply to the heater “ON”.

Lime Scale

Over time all immersion type elements accumulate lime scale on their surfaces. Various conditions affecting this buildup include:

- Volume of hot water used; as the consumption of hot water increases, more scale results.
- Water temperature; the hotter the water the more scale is deposited.
- Purity of the water supply.

If it becomes necessary to delime the elements, use a non-metallic (soft) tool or scraper to remove the scale taking care not to damage the surface of the element. Alternatively, use a non-muriatic delimer that is approved for use with potable water to dissolve the lime scale.

DANGER! Do not use muriatic or hydrochloric acid based deliming solutions.

Troubleshooting Checklist

Before placing a service call, perform the following checks to see if the problem can be identified and corrected easily. Correcting a fault identified by this list may eliminate the need for a service call and quickly restore hot water service. Refer to Figure 1 to identify the location of all of the heater’s major components.

DANGER! BE SURE TO TURN OFF THE POWER TO THE HEATER WHEN CHECKING EQUIPMENT.

Insufficient or no hot water:

1. Ensure the electrical supply to the water heater is in the "ON" position.
 - Check that all the fuses are intact;
 - Fuses are usually contained in the electrical disconnect switch.
 - There are also fuses in the heater control panel.
 3. If the water is now cold but was excessively hot, the high-limit switch may have tripped.
 - To reset, open the component panel cover, remove the insulation plug to access the high-limit switch. Depress the red button to manually reset the switch.
- NOTE:** If the high-limit switch trips repeatedly the water heater should be inspected by a qualified service technician.
4. A large demand for hot water may have been more than the heater can supply.
 - Allow a recovery period to restore water temperature after large demands.
 5. Check incoming water supply temperature.
 - If the incoming water temperature is cooler than normal, it will lengthen the time required to heat water to the desired temperature.
 6. Look for leakage in the hot water supply lines.
 7. Operation of the water heater may be affected by the buildup of sediment or lime scale.
 - Follow the instructions given in “Draining, Flushing and Sediment Removal”.

Water heater is noisy:

1. The heater makes sizzling and hissing noises operating.
 - The accumulation of sediment or lime scale may be the cause. The sounds are normal; however, the tank bottom and elements should be cleaned. Follow the instructions given in "Draining, Flushing and Sediment Removal".
2. Some of the electrical components of the water heater controls make noises.
 - Most of these are normal. Contactors will "click" or snap as the heater starts and stops, transformers and contacts often hum.

Water leakage is suspected or apparent:

Refer to "Leakage Checkpoints" (Figure 13) to locate potential leakage points.

1. Make sure the heater drain valve is fully closed.
2. Discharge from the outlet of the T&P relief valve may indicate:
 - Faulty relief valve.
 - Excessive water temperature.
 - Excessive water pressure.

A common cause of relief valve leakage is excessive water pressure. This condition is often caused by a "closed system". A closed system has a check valve in the inlet system that prevents the expanded hot water volume to equalize pressure with the main system. If a relief valve does not release this pressure, it will damage the water heater or plumbing system.

3. Remove the cover and insulation from the element compartment.
 - Examine the area around the element gasket for leakage.
 - Tighten the elements if necessary. If tightening the elements does not stop the leak it may be necessary to replace the gaskets.

IF YOU CANNOT IDENTIFY OR CORRECT THE SOURCE OF MALFUNCTION

1. Turn the electrical supply to the heater "OFF".
2. Close the cold water supply valve.
3. Call a qualified service technician.

VIII) LEAKAGE CHECKPOINTS

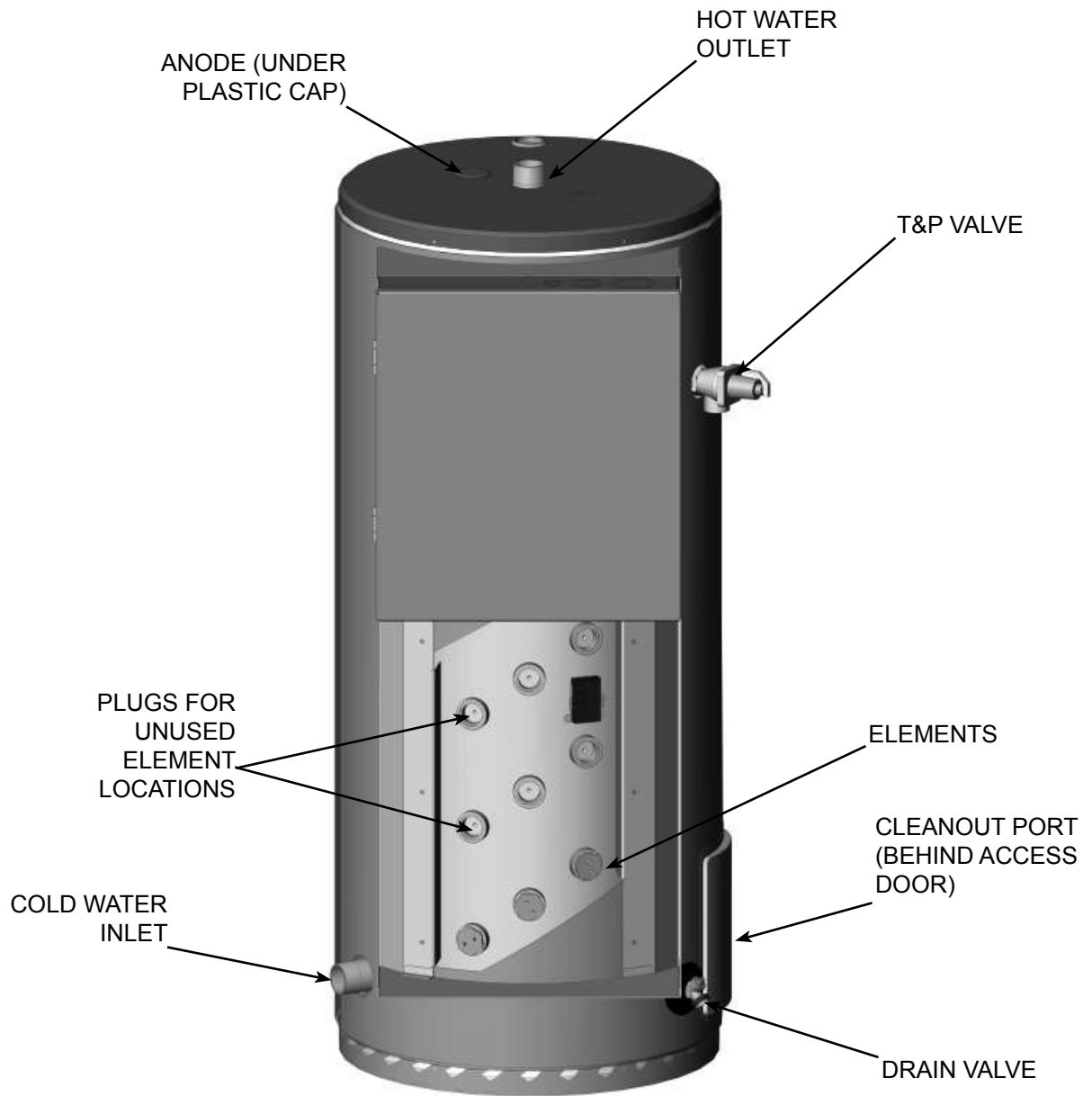

FIGURE 13: Possible leakage points

IX) FLOOR SEALING

Installation Instructions

WARNING

IMPROPER INSTALLATION, ADJUSTMENT OR ALTERATION OF THESE COMPONENTS CAN CAUSE NON-COMPLIANCE TO NSF SPECIFICATIONS. ONLY A QUALIFIED INSTALLER, SERVICE AGENT, OR CERTIFIED FACTORY REPRESENTATIVE SHALL INSTALL THE NSF CONSTRUCTION COMPONENTS.

General

The installation of the floor sealant is a requirement for NSF construction compliance.

Tools And Materials Required:

1. Floor sealant (Dow Corning RTV Sealant #732).
2. Standard caulk gun.

WARNING

THE MANUFACTURER OF THIS WATER HEATER WILL NOT ASSUME ANY LIABILITY FOR ANY DAMAGE RESULTING FROM FAILURE TO COMPLY WITH THESE INSTRUCTIONS. READ THESE INSTRUCTIONS THOROUGHLY BEFORE STARTING.

Installation Procedure

Before proceeding with the sealing of this heater to comply with NSF requirements, ensure this water heater has been installed in accordance with local and provincial or, in the absence of local and provincial codes, with the latest edition of “**Canadian Electrical Code**”. Refer to the installation instructions provided with this water heater.

1. Thoroughly read and understand the floor sealant instructions.
2. Thoroughly read and understand the installation instruction manual supplied with the heater before beginning the installation.
3. Ensure the water heater has been installed in accordance with the installation instructions for this water heater and/or with local codes and ordinances.
4. Seal the heater base to the drain pan and the drain pan to the floor with the sealant listed above. Be certain that there are no gaps or openings in the seal (See Figure 14).
5. If a drain pan is not installed seal the unit base to the floor with the sealant listed above. Be certain that there are no gaps or openings in the seal (See Figure 15).

NOTE: The NSF certification requires the heater to be designed, constructed and installed to prevent the harborage of vermin and the accumulation of dirt and debris.

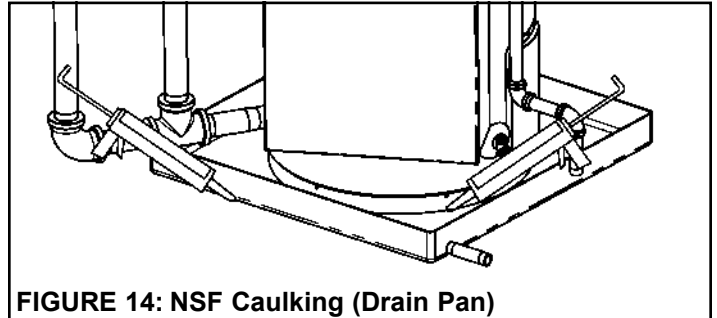

FIGURE 14: NSF Caulking (Drain Pan)

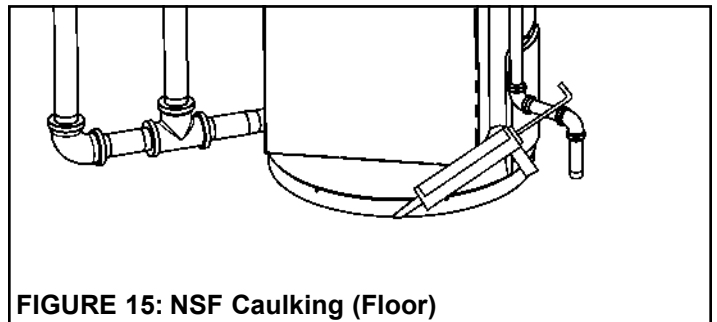
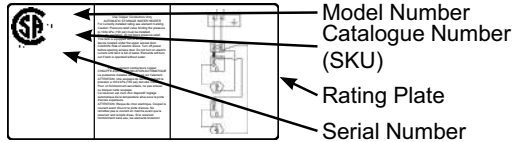

FIGURE 15: NSF Caulking (Floor)

When referencing the water heater for service or warranty, please refer to the rating plate affixed to the unit for the following information:



Warranty Code:	P	R	S	U	V	W	Y
Inner Tank Warranty Years:	3	5	6	8	9	10	12
Component Part Warranty Years:	1	1	1	2	1	1	1

The Serial Number contains the warranty and manufacture date information for the unit as follows:

U9999 F999999
 Warranty code _____
 Year of manufacture _____
 Week of manufacture _____

Example: U1005 F001234
 Manufactured in week 5
 Manufactured in 2010
 8 year tank, 2 year parts warranty

The Warranty Code indicates the inner tank and component part warranties as shown in the table above.

LIMITED WARRANTY

RESIDENTIAL STORAGE TANK TYPE WATER HEATER FOR INSTALLATION IN A SINGLE FAMILY DWELLING

A. WHO IS COVERED.

GSW WATER HEATING AND ITS SUPPLIERS, (herein collectively referred to as "Manufacturer") warrants only to the original consumer purchaser (hereinafter "Owner") of the water heater, within the boundaries of the continental United States or Canada, or their territories, so long as he or she continuously occupies the single family dwelling in which this water heater is initially installed for the period specified below. This Warranty is not transferable. This Warranty is reduced to one year if the water heater is used in a commercial or industrial application, or if the water heater is used to supply more than one dwelling unit. Consumers must retain point-of-sale proof of purchase to validate warranty entitlement.

B. WHEN IT IS COVERED.

The water heater is warranted only when it is installed, operated, and maintained in accordance with the printed instructions accompanying the water heater. The water heater shall/must be installed in such a manner that, if the tank or any connection thereto should leak, the resulting flow of water will not cause damage to the area in which it is installed. The water heater's temperature and pressure relief valve must be piped to the nearest drain to avoid damage in the event the valve is actuated. For detailed instructions, read the manual accompanying the water heater and review drawings in the manual.

C. WHAT THE MANUFACTURER WILL DO AND THE PERIOD OF COVERAGE.

1. **The Inner Tank.** If the inner tank leaks within the warranty period shown in the table above after the original installation, the Manufacturer will furnish a new water heater of the Manufacturer's then prevailing comparable model. If industry standards, regulatory changes, product improvements, or product obsolescence prohibits the Manufacturer from furnishing an identical model replacement water heater under this Warranty, the Owner will be furnished with a new water heater of comparable capacity; however, the Owner will be charged for the additional value of the item(s) which the Manufacturer has incorporated in the replacement water heater. A prior authorization number must be obtained from the Manufacturer before replacing the water heater. This Warranty is limited to one replacement water heater at the original installation site.
2. **Component Part.** If any component, part other than the inner tank, proves to the Manufacturer's satisfaction to be defective in material or workmanship within the warranty period shown in the table above after the original installation, the Manufacturer will furnish the Owner with a replacement for the defective part(s). This Warranty is limited to one replacement component part for each original part.
3. **Return of Defective Water Heater and Component Parts.** The Manufacturer reserves the right to examine the alleged defect in the water heater or component part(s). As such, it will be the Owner's obligation (see paragraph D. 3) to return the water heater and/or component part(s) to the Manufacturer.
 - a. When returning a water heater, it must include all component parts and the rating plate label.
 - b. When returning component part(s), they must be individually tagged and identified with the water heater's Model Number, SKU, Serial Number, date of purchase, and date of installation.
 - c. THERE ARE NO WARRANTIES WHICH EXTEND BEYOND THE DESCRIPTION ON THE FACE HEREOF. THIS EXPRESS WARRANTY IS, WHERE PERMITTED BY LAW, IN LIEU OF AND EXCLUDES AND REPLACES ALL OTHER CONDITIONS, WARRANTIES, GUARANTEES, REPRESENTATIONS, OBLIGATIONS OR LIABILITIES OF THE MANUFACTURER OF ANY NATURE OR KIND, EXPRESS OR IMPLIED, HOWEVER ARISING (WHETHER BY CONTRACT, CONDUCT, STATEMENT, STATUTE, NEGLIGENCE, PRINCIPLES OF MANUFACTURER'S LIABILITY, OPERATION OF LAW, OR OTHERWISE) WITH RESPECT TO THE UNIT OR ITS FITNESS FOR A PARTICULAR PURPOSE, MERCHANTABILITY, INSTALLATION, OPERATION, REPAIR, OR REPLACEMENT. THE MANUFACTURER EXPRESSLY DISCLAIMS ANY AND ALL IMPLIED WARRANTIES. IN NO EVENT WILL THE MANUFACTURER'S LIABILITIES EXCEED THE COST OF THE DEFECTIVE PART(S) OR UNIT.

D. WHAT THIS WARRANTY DOES NOT COVER.

1. The Unit must not be installed where water damage can result from a leak, while provision(s) shall be made for directing any water escaping from the Unit to a properly operating drainpipe. As all units of this type may eventually leak, you must protect against any potential water damage. The Manufacturer accepts no responsibility for such damage, nor any incidental or consequential loss, nor damage(s) related thereto, suffered by the Owner of the Unit nor by any third party.
2. The Manufacturer shall not be liable under this Warranty and this Warranty shall be void and have no effect if the following events occur:
 - a. The water heater or any of its component parts have been subject to misuse, alteration, neglect, or accident; or

- b. The water heater has not been installed in accordance with the applicable local plumbing and/or building code(s) and/or regulations or, in their absence, with the latest edition of the Natural Gas and Propane Installation Code, and/or the Canadian Electrical Code; or
 - c. The water heater is not installed, operated, and maintained in accordance with the Manufacturer's instructions, including if the water heater has any additional aftermarket equipment introduced into the sealed system not approved by the Manufacturer; or
 - d. The water heater or any of its component parts are damaged or fails from operation with an empty or partially empty tank (such as, but not limited to elements burned out in a dry tank); or
 - e. The water heater or any part has been under water; or
 - f. The water heater is exposed to highly corrosive atmospheric conditions. No warranty extends, for example, and without limitation of the foregoing, to Units exposed to: salts, chemicals, exhausts, pollutants, or contaminants; or
 - g. The water heater is not continuously supplied with potable water; or
 - h. The water heater replacement is requested for reasons of noise, taste, odour, discolouration, and/or rust; or
 - i. The water heater is operated at temperatures exceeding the maximum setting of the thermostat and/or high limit control provided by the Manufacturer, or at water pressures exceeding the pressure reading stated on the Unit; or
 - j. The water heater is operated without an operating anode; or
 - k. The water heater is supplied or operated with deionized water; or
 - l. The water heater is removed from its original installation location; or
 - m. The water heater is installed outdoors (this water heater is intended only for indoor installation); or
 - n. The water heater is converted, or is attempted to be converted, from one voltage or wattage to another, if an electric water heater, or from one gas type to another, if a gas water heater; or
 - o. The water heater has not been fired at the factory rated input and fuel for which it was factory built; or
 - p. The water heater or any of its component parts fail due to sediment build-up; or
 - q. The water heater does not have installed a properly operating temperature and pressure relief valve, certified to ANSI Z21.22/CSA "Requirements for Relief Valves for Hot Water Supply Systems"; or
 - r. The water heater or any of its component parts fail because of fire, floods, lightning, or any other act of God, or any other contingency beyond the control of the Manufacturer; or
 - s. The water heater is installed in a closed system without adequate provision for thermal expansion.
3. Except when specifically prohibited by the applicable law, the Owner, and not the Manufacturer, shall be liable for and shall pay for all charges for labour or other expenses incurred in the removal, repair, or replacement of the water heater or any component part(s) claimed to be defective or any expense incurred to remedy any defect in the product. Such charges may include, but are not necessarily limited to:
- a. All freight, shipping, handling, and delivery costs of forwarding a new water heater or replacement part(s) to the Owner.
 - b. All costs necessary or incidental in removing the defective water heater or component part(s) and installing a new water heater or component part(s).
 - c. Any material required to complete and/or permits required for the installation of a new water heater or replacement part(s), and
 - d. All costs necessary or incidental in returning the defective water heater or component part(s) to a location designated by the Manufacturer.
4. The terms of this Limited Warranty cannot be modified by any person, whether or not he/she claims to represent or act on behalf of the Manufacturer.
- E. HOW THE ORIGINAL OWNER CAN MAKE A WARRANTY CLAIM.**
- 1. The Owner should submit the warranty claim direct to the Manufacturer's Service Department, at the address or phone number listed below, and the Manufacturer will arrange for the handling of the claim.
 - 2. Whenever any inquiry or request is made, be sure to include the water heater's Catalogue Number, Model Number, Serial Number, date of purchase, date of installation, and location of installation.

This Warranty and the Manufacturer's obligations shall be construed and determined in accordance with the laws of both the Province of Ontario, and of Canada in force therein. This Warranty does not affect specific legal rights of a consumer under applicable law, except to the extent that such rights may be waived or replaced, and the provisions hereof are deemed to be amended to the extent necessary. The unenforceability of any provision, in whole or in part, of this Certificate shall not affect the remaining provisions. Any and all repair and/or replacement of part(s) or Unit are the sole and exclusive remedy available against the Manufacturer.

GSW Water Heating
 599 Hill Street West
 Fergus, ON Canada N1M 2X1
 Should you have any questions, please
 Visit us online at www.gsw-wh.com or www.johnwoodwaterheaters.com, or
 E-mail us at techsupport@gsw-wh.com, or
 Call our Technical Support line at 1 888 GSW TECH (479 8324)