

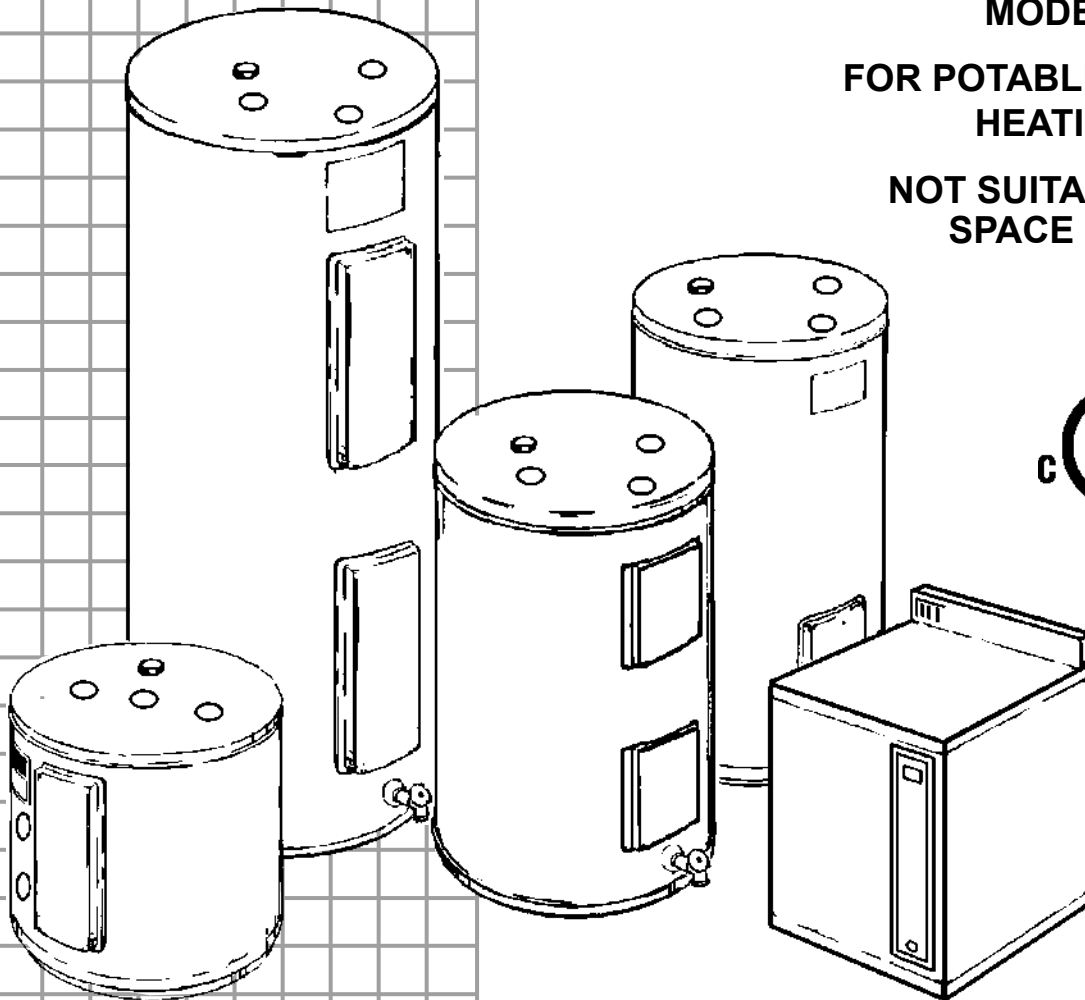

WATER HEATERS

MODELS 6-120

FOR POTABLE WATER
HEATING ONLYNOT SUITABLE FOR
SPACE HEATING

| | |
|--|---|
|  | <p>⚠ WARNING</p> <p>Read and understand this instruction manual and safety messages before installing, operating, or servicing this water heater.</p> <p>Failure to follow these instructions and safety messages could result in death or serious injury.</p> <p>This manual must remain with water heater.</p> |
|--|---|

ALL TECHNICAL AND WARRANTY QUESTIONS: SHOULD BE DIRECTED TO THE LOCAL DEALER FROM WHOM THE WATER HEATER WAS PURCHASED. IF YOU ARE UNSUCCESSFUL, PLEASE WRITE TO THE COMPANY LISTED ON THE RATING PLATE ON THE WATER HEATER.





**KEEP THIS MANUAL IN THE POCKET ON HEATER FOR FUTURE REFERENCE
WHEN EVER MAINTENANCE ADJUSTMENT OR SERVICE IS REQUIRED.**

SAFE INSTALLATION, USE AND SERVICE

Your safety and the safety of others is extremely important in the installation, use, and servicing of this water heater.

Many safety-related messages and instructions have been provided in this manual and on your own water heater to warn you and others of a potential injury hazard. Read and obey all safety messages and instructions throughout this manual. It is very important that the meaning of each safety message is understood by you and others who install, use, or service this water heater.

| | |
|---|--|
|  | This is the safety alert symbol. It is used to alert you to potential personal injury hazards. Obey all safety messages that follow this symbol to avoid possible injury or death. |
|---|--|

| | |
|---|---|
|  | DANGER indicates an imminently hazardous situation which, if not avoided, will result in death or injury. |
|  | WARNING indicates a potentially hazardous situation which, if not avoided, could result in death or injury. |
|  | CAUTION indicates a potentially hazardous situation which, if not avoided, could result in minor or moderate injury. |
|  | CAUTION used without the safety alert symbol indicates a potentially hazardous situation which, if not avoided, could result in property damage. |

All safety messages will generally tell you about the type of hazard, what can happen if you do not follow the safety message, and how to avoid the risk of injury.

IMPORTANT DEFINITIONS

- **Qualified Installer:** A qualified installer must have ability equivalent to a licensed tradesman in the fields of plumbing and electrical installation of these appliances. This would include a thorough understanding of the requirements of the Canadian Electrical Code and applicable local electrical and plumbing codes (and tools necessary to confirm proper installation and operation of the water heater) as they relate to the installation of electric water heaters. The qualified installer must have a thorough understanding of the water heater Instruction Manual.
- **Service Agency:** A service agency also must have ability equivalent to a licensed tradesman in the fields of plumbing and electrical installation of these appliances. This would include a thorough understanding of the requirements of the Canadian Electrical Code and applicable local electrical and plumbing codes (and tools necessary to confirm proper installation and operation of the water heater) as they relate to the installation of electric water heaters. The service agency must have a thorough understanding of the water heater Instruction Manual.

GENERAL SAFETY

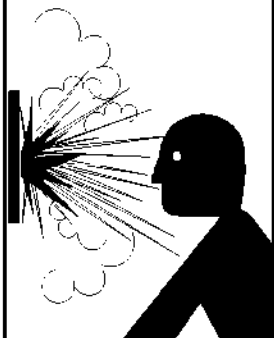

| | |
|---|---|
|  | ⚠ WARNING |
| | <p>Read and understand this instruction manual and safety messages before installing, operating, or servicing this water heater.</p> <p>Failure to follow these instructions and safety messages could result in death or serious injury.</p> <p>This manual must remain with water heater.</p> |

| |
|--|
| CAUTION |
| Improper installation and use may result in property damage. |
| <ul style="list-style-type: none">• Do not operate water heater if flood damaged.• Inspect and replace anode.• Install in location with drainage.• Fill tank with water before operation.• Be alert for thermal expansion. <p>Refer to this manual for installation and service.</p> |

| | |
|--|--|
|  | ⚠ WARNING |
| | Explosion Hazard <ul style="list-style-type: none">• Overheated water can cause water tank explosion.• Properly sized temperature and pressure relief valve must be installed in opening provided. |

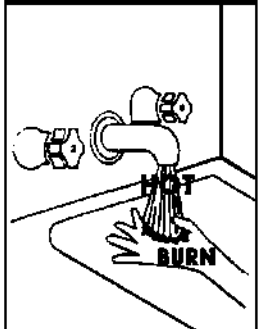
| | |
|--|--|
|  | ⚠ WARNING |
| | <ul style="list-style-type: none">• Before removing any access panels or servicing the water heater, make sure the electrical supply to the water heater is turned "OFF."• Failure to do this could result in death, serious bodily injury, or property damage. |

| | |
|---|---|
| ⚠ DANGER | <p>Water temperature over 125°F (52°C) can cause severe burns instantly resulting in severe injury or death.</p> <p>Children, the elderly, and the physically or mentally disabled are at highest risk for scald injury.</p> <p>Feel water before bathing or showering.</p> <p>Temperature limiting valves are available.</p> <p>Read this instruction manual for safe temperature setting.</p> |
|  | |

| | | |
|---|--|---|
| ⚠ WARNING | | |
| Fire Hazard / Electric Shock Hazard | | |
|  | <ul style="list-style-type: none">• Do not use this water heater with any voltage other than shown on the model rating plate.• Failure to use the correct voltage shown on the model rating plate could result in death, serious bodily injury, or property damage. |  |

INTRODUCTION

Thank You for purchasing this water heater. Properly installed and maintained, it should give you years of trouble free service.

Abbreviations Found In This Instruction Manual:

- CAN - Canada
- CSA - Canadian Standards Association
- ANSI - American National Standards Institute
- ULC - Underwriters Laboratories of Canada

PREPARING FOR THE INSTALLATION

1. Read the "General Safety" section of this manual first and then the entire manual carefully. If you don't follow the safety rules, the water heater will not operate properly. It could cause DEATH, SERIOUS BODILY INJURY, AND/OR PROPERTY DAMAGE.

This manual contains instructions for the installation, operation, and maintenance of the electric water heater. It also contains warnings throughout the manual that you must read and understand. All warnings and all instructions are essential to the proper operation of the water heater and your safety.

READ THE ENTIRE MANUAL BEFORE ATTEMPTING TO INSTALL OR OPERATE THE WATER HEATER.

2. The installation must conform with these instructions and the local code authority having jurisdiction and the requirements of the power company. In the absence of local code requirements, with the current edition of the Canadian Electrical Code CSA C22.1. This publication is available from your local government, library, electric company or by writing Canadian Standards Association, 5060 Spectrum Way Suite 100, Mississauga, Ontario, Canada L4W 5N6.
3. If after reading this manual you have any questions or do not understand any portion of the instructions, contact the local utility or the manufacturer whose name appears on the rating plate.
4. Carefully plan your intended placement of the water heater. **INSTALLATION OR SERVICE OF THIS WATER HEATER REQUIRES ABILITY EQUIVALENT TO THAT OF A LICENSED TRADESMAN IN THE FIELD INVOLVED. PLUMBING AND ELECTRICAL WORK ARE REQUIRED.**

Examine the location to ensure the water heater complies with the "Facts to Consider About the Location" section in this manual.

TABLE OF CONTENTS

| | |
|--|-------|
| SAFE INSTALLATION, USE AND SERVICE..... | 2 |
| GENERAL SAFETY..... | 3 |
| INTRODUCTION..... | 4 |
| Preparing for the New Installation..... | 4 |
| TABLE OF CONTENTS..... | 4 |
| TYPICAL INSTALLATION..... | 5 |
| MIXING VALVE USAGE..... | 6 |
| LOCATING THE NEW WATER HEATER..... | 6-7 |
| Facts to Consider About Location..... | 6 |
| Insulation Blankets..... | 7 |
| INSTALLING THE NEW WATER HEATER..... | 7 |
| Water Piping..... | 7-8 |
| Water Piping Pressure Test..... | 8 |
| Temperature-Pressure Relief Valve..... | 9-10 |
| Filling the Water Heater..... | 10 |
| T & P Valve and Pipe Insulation (Selected Models)..... | 10 |
| WIRING DIAGRAMS..... | 11 |
| WIRING..... | 12 |
| TEMPERATURE REGULATION..... | 13 |
| Temperature Adjustment..... | 13 |
| FOR YOUR INFORMATION..... | 14 |
| Thermal Expansion..... | 14 |
| Strange Sounds..... | 14 |
| Operational Conditions..... | 14 |
| Water Odor..... | 14 |
| "Air" in Hot Water Faucets..... | 14 |
| High Water Temperature Shut Off System..... | 14 |
| PERIODIC MAINTENANCE..... | 15-18 |
| Anode Rod Inspection and Replacement..... | 15 |
| Temperature-Pressure Relief Valve Operation..... | 15 |
| Draining and Flushing..... | 15-16 |
| Thermostat Removal/Replacement..... | 16 |
| Element Cleaning/Replacement..... | 16-18 |
| Drain Valve Washer Replacement..... | 18 |
| Service..... | 18 |
| LEAKAGE CHECKPOINTS..... | 19 |
| TROUBLESHOOTING GUIDELINES..... | 20 |
| REPAIR PARTS LIST..... | 21-23 |
| WARRANTY..... | 24-25 |

TYPICAL INSTALLATION

UPRIGHTS/LOWBOYS

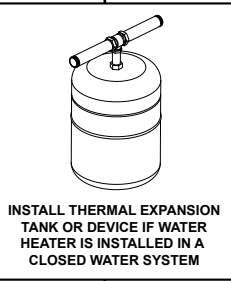
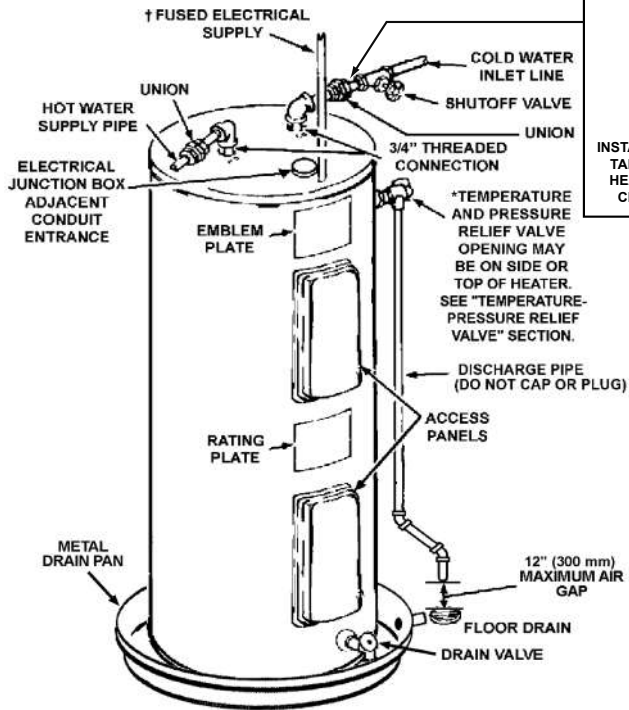

COMPACTS

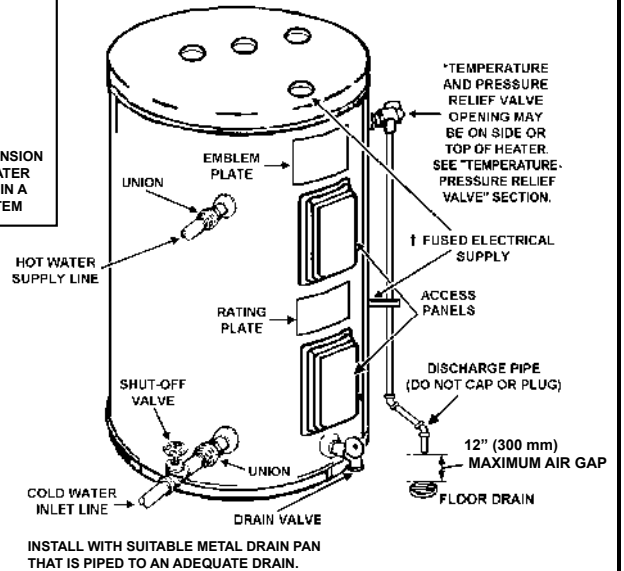

↑ ELECTRICAL CONNECTIONS MAY BE LOCATED ON THE TOP OR SIDE, REFER TO YOUR UNIT. ACTUAL MODEL AND ILLUSTRATION MAY VARY DEPENDENT ON MODEL CAPACITY AND TYPE. SOME MODELS HAVE ALTERNATE INLET, OUTLET AND T&P VALVE LOCATIONS. THESE ALTERNATE LOCATIONS ARE IDENTIFIED BY THE LABELING ON THE UNIT.

TABLE TOPS

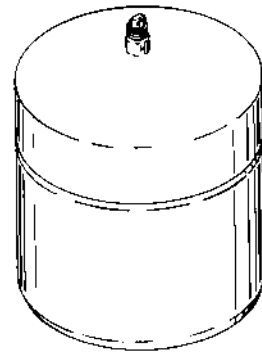
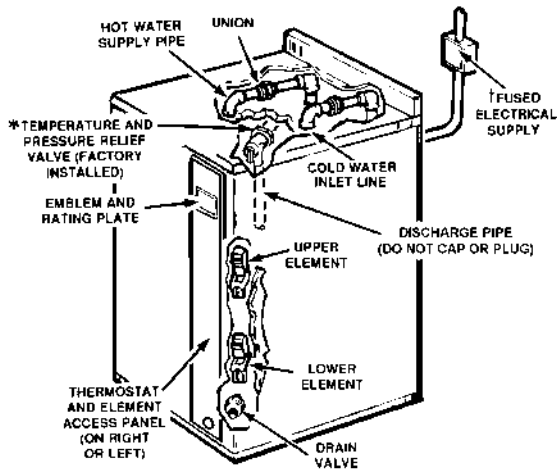

INSTALL THERMAL EXPANSION TANK OR DEVICE IF WATER HEATER IS INSTALLED IN A CLOSED WATER SYSTEM.



INSTALL VACUUM RELIEF IN COLD WATER INLET LINE AS REQUIRED BY LOCAL CODES.



INSTALL SUITABLE METAL DRAIN PANS UNDER HEATERS TO PREVENT DAMAGE DUE TO LEAKAGE. REFER TO WATER HEATER LOCATION, SEE "INSTALLING THE NEW WATER HEATER" SECTION.

FIGURE 1.

MIXING VALVE USAGE

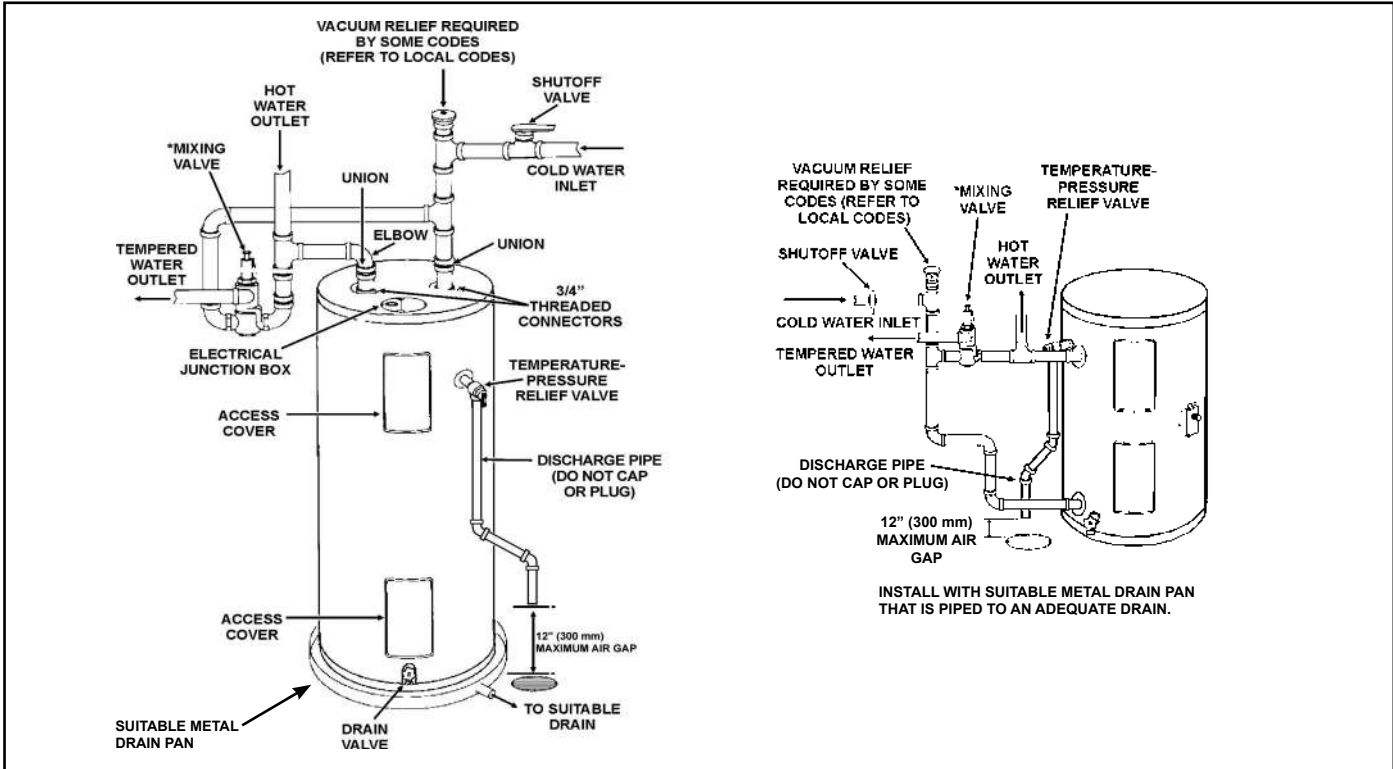

FIGURE 2.

Water (Potable) Heating: All models are considered suitable for water (potable) heating only.

HOTTER WATER CAN SCALD:

| | |
|--|--|
| | <p>▲ DANGER Water temperature over 125°F (52°C) can cause severe burns instantly resulting in severe injury or death.</p> |
| | <p>Children, the elderly, and the physically or mentally disabled are at highest risk for scald injury.</p> |
| | <p>Feel water before bathing or showering.</p> |
| | <p>Temperature limiting valves are available.</p> |
| | <p>Read this instruction manual for safe temperature setting.</p> |

Water heaters are intended to produce hot water. Water heated to a temperature which will satisfy space heating, clothes washing, dish washing, and other sanitizing needs can scald and permanently injure you upon contact. Some people are more likely to be permanently injured by hot water than others. These include the elderly, children, the infirm, or physically/mentally disabled. If anyone using hot water in your home fits into one of these groups or if there is a local code or provincial law requiring a certain temperature water at the hot water tap, then you must take special precautions. In addition to using the lowest possible temperature setting that satisfies your hot water needs, a means such as a mixing valve should be used at the hot water taps used by these people or at the water heater. Mixing valves are available from your local plumbing contractor. Consult a Qualified Installer or Service Agency. Follow mixing valve manufacturer's instructions for installation of the valves. Before changing the factory setting on the thermostat, read the "Temperature Regulation" section in this manual.

LOCATING THE NEW WATER HEATER

FACTS TO CONSIDER ABOUT THE LOCATION

| |
|--|
| <p>CAUTION</p> <p>Property Damage Hazard</p> |
| <ul style="list-style-type: none"> • All water heaters eventually leak • Do not install without adequate drainage. |

Carefully choose an indoor location for the new water heater, because the placement is a very important consideration for the

safety of the occupants in the building and for the most economical use of the appliance.

Whether replacing an old water heater or putting the water heater in a new location, the following critical points must be observed:

1. Select a location indoors as close as practical or centralized to the water piping system as possible. The water heater should be located in an area not subject to freezing temperatures.
2. Selected location must provide adequate clearances (4 in/10 cm) for servicing parts such as the thermostats, drain valve, and relief valve. Adequate clearance for servicing this appliance should be considered before installation, such as changing the anodes, etc.

- The water heater should be located so it is not subject to physical damage by moving vehicles or area flooding.

Installation of the water heater must be accomplished in such a manner that if the tank or any connections should leak, the flow will not cause damage to the structure. For this reason, it is not advisable to install the water heater in an attic or upper floor. When such locations cannot be avoided, a suitable metal drain pan should be installed under the water heater. Metal drain pans are available from your local plumbing contractor. Such a drain pan must have a minimum length and width of at least 2 inches (51 mm) greater than the water heater dimensions and must be piped to an adequate drain.

Water heater life depends upon water quality, water pressure and the environment in which the water heater is installed. Water heaters are sometimes installed in locations where leakage may result in property damage, even with the use of a metal drain pan piped to a drain. However, unanticipated damage can be reduced or prevented by a leak detector or water shut-off device used in conjunction with a piped metal drain pan. These devices are available from some plumbing supply wholesalers and retailers, and detect and react to leakage in various ways:

- Sensors mounted in the metal drain pan that trigger an alarm or turn off the incoming water to the water heater when leakage is detected.
- Sensors mounted in the metal drain pan that turn off the water supply to the entire home when water is detected in the drain pan.

- Water supply shut-off devices that activate based on the water pressure differential between the cold water and hot water pipes connected to the water heater.

INSULATION BLANKETS

Insulation blankets are available to the general public for external use on electric water heaters but are not necessary with this product. The purpose of an insulation blanket is to reduce the standby heat loss encountered with storage tank heaters. Your water heater meets or exceeds the NRCAN standards with respect to insulation and standby loss requirements, making an insulation blanket unnecessary.

Should you choose to apply an insulation blanket to this heater, you should follow these instructions below. Failure to follow these instructions can result in fire, serious personal injury, or death.

- Do not cover the temperature and pressure relief (T & P) valve with an insulation blanket.
- Do not cover the instruction manual. Keep it on the side of the water heater or nearby for future reference.
- Do obtain new warning and instruction labels for placement on the blanket directly over the existing labels.

INSTALLING THE NEW WATER HEATER

WATER PIPING

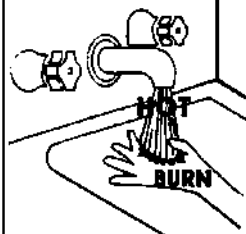
| | |
|---|---|
| ⚠ DANGER | <p>Water temperature over 125°F (52°C) can cause severe burns instantly resulting in severe injury or death.</p> <p>Children, the elderly, and the physically or mentally disabled are at highest risk for scald injury.</p> <p>Feel water before bathing or showering.</p> <p>Temperature limiting valves are available.</p> <p>Read this instruction manual for safe temperature setting.</p> |
|  | |

HOTTER WATER CAN SCALD:

Water heaters are intended to produce hot water. Water heated to a temperature which will satisfy space heating, clothes washing, dish washing, cleaning and other sanitizing needs can scald and permanently injure you upon contact. Some people are more likely to be permanently injured by hot water than others. These include the elderly, children, the infirm, or physically/mentally disabled. If anyone using hot water in your home fits into one of these groups or if there is a local code or provincial law requiring a certain temperature water at the hot water tap, then you must take special precautions. In addition to using the lowest possible temperature setting that satisfies your hot water needs, a means such as a mixing valve should be used at the hot water taps used by these people or at the water heater. Valves for reducing point of use temperature by mixing cold and hot water are also available.

Consult a Qualified Installer or Service Agency. Follow manufacturer's instructions for installation of the valves. Before changing the factory setting on the thermostat, read the "Temperature Regulation" section in this manual.

| |
|---|
| ⚠ WARNING |
| Toxic Chemical Hazard |
| <ul style="list-style-type: none"> Do not connect to non-potable water system. |

This water heater shall not be connected to any heating systems or component(s) used with a non-potable water heating appliance.

Use properly sized water heaters for spa or hot tub use.

Toxic chemicals, such as those used for boiler treatment shall not be introduced into this system.

Water supply systems may, because of such events as high line pressure, frequent cut-offs, the effects of water hammer among others, have installed devices such as pressure reducing valves, check valves, back flow preventers, etc. to control these types of problems. When these devices are not equipped with an internal by-pass, and no other measures are taken, the devices cause the water system to be closed. As water is heated, it expands (thermal expansion) and closed systems do not allow for the expansion of heated water.

The water within the water heater tank expands as it is heated and increases the pressure of the water system. If the relieving point of the water heater's temperature-pressure relief valve is reached, the valve will relieve the excess pressure. **The temperature-pressure relief valve is not intended for the constant relief of thermal expansion.** This is an unacceptable condition and must be corrected. It is recommended that any devices installed which could create a closed system have a by-pass and/or the system have an expansion tank or device to relieve the pressure built by thermal expansion in the water system. Expansion tanks are available for ordering through a local plumbing contractor. Contact the local water supplier and/or a service agency for assistance in correcting these situations.

NOTE: To protect against untimely corrosion of hot and cold water fittings, it is strongly recommended that di-electric unions or couplings be installed on this water heater when connected to copper pipe.

WATER PIPING PRESSURE TEST

| |
|--|
| CAUTION |
| Property Damage Hazard |
| <ul style="list-style-type: none"> • Avoid water heater damage. • Install thermal expansion tank if necessary. • Do not apply heat to cold water inlet. • Contact qualified installer or service agency. |

| |
|--|
| WARNING |
| Air Pressure Hazard |
| <ul style="list-style-type: none"> • If water piping system is to be air pressure tested, the water heater must be disconnected from the water piping system. • Failure to disconnect the water heater during air pressure testing of the water system could result in DEATH, SERIOUS BODILY INJURY, OR PROPERTY DAMAGE. |

Figure 3A shows the typical attachment of the water piping to the water heater. The water heater is equipped with 3/4 inch NPT water connections.

NOTE: If using copper tubing, solder tubing to an adapter before attaching the adapter to the cold water inlet connection. Do not solder the cold water supply line directly to the cold water inlet, it will harm the dip tube and damage the tank.

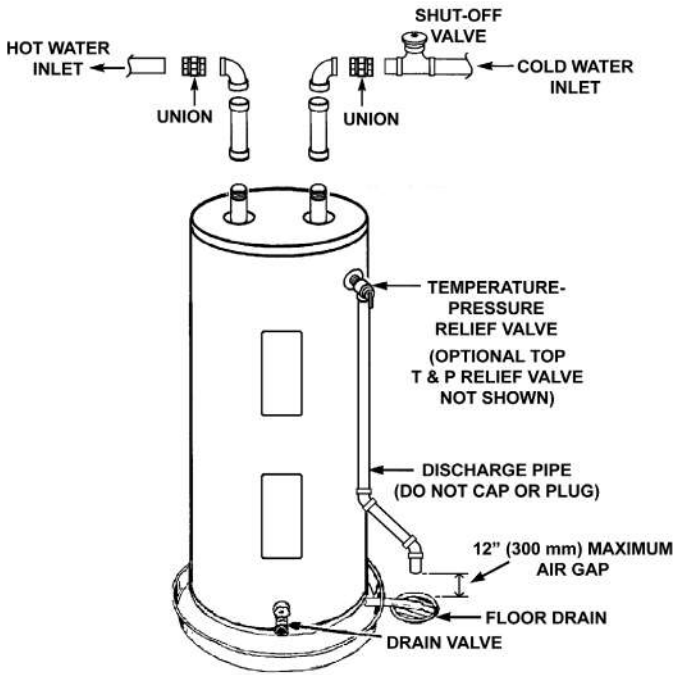

FIGURE 3A.

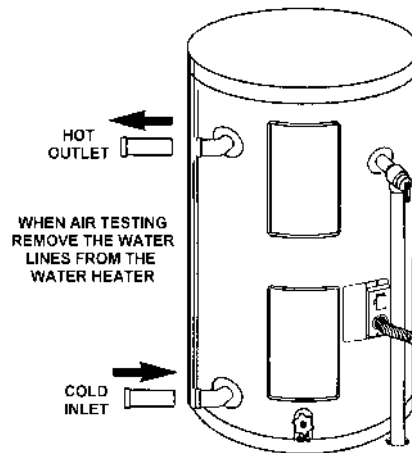
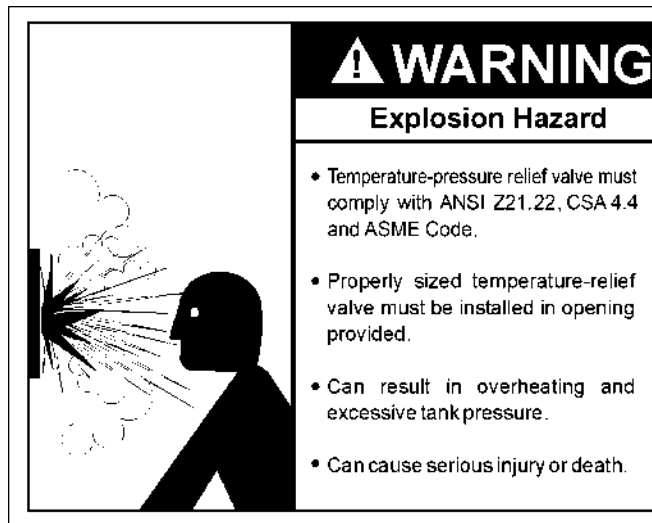

FIGURE 3B.

TEMPERATURE-PRESSURE RELIEF VALVE



This water heater is provided with a properly certified combination temperature - pressure relief valve by the manufacturer.

The valve is certified by a nationally recognized testing laboratory that maintains periodic inspection of production of listed equipment of materials as meeting the requirements for Relief Valves for Hot Water Supply Systems, ANSI Z21.22/CSA 4.4-current edition, and the code requirements of ASME.

If replaced, the valve must meet the requirements of local codes, but not less than a combination temperature and pressure relief valve certified as indicated in the above paragraph.

The valve must be marked with a maximum set pressure not to exceed the marked hydrostatic working pressure of the water heater (150 psi = 1,035 kPa) and a discharge capacity not less than the water heater input rate as shown on the model rating plate (Electric heaters - watts x 3.412 equal BTU/hr rate).

For safe operation of the water heater, the relief valve must not be removed from its designated opening nor plugged.

The temperature-pressure relief valve must be installed directly into the fitting of the water heater designed for the relief valve. Position the valve downward and provide tubing so that any discharge will exit only within 12 inches (300 mm) above an adequate drain, or external to the building or structure. Be certain that no contact is made with any live electrical part. The discharge opening must not be blocked or reduced in size under any circumstances. Excessive length, over 30 feet (9.14 m), or use of more than four elbows can cause restriction and reduce the discharge capacity of the valve.

No valve or other obstruction is to be placed between the relief valve and the tank. Do not connect tubing directly to discharge drain unless a 12 inch air gap is provided. The relief valve must be allowed to discharge water in sufficient quantities, should circumstances demand, to prevent bodily injury, hazard to life, or property damage. If the discharge pipe is not connected to a drain or other suitable means, the water flow may cause property damage.

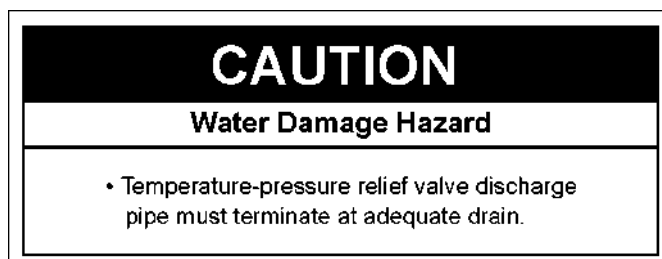

The Discharge Pipe:

- Shall not be smaller in size than the outlet pipe size of the valve, or have any reducing couplings or other restrictions.
- Shall not be plugged or blocked.
- Shall be of material listed for hot water distribution.
- Shall be installed so as to allow complete drainage of both the temperature-pressure relief valve, and the discharge pipe.
- Shall terminate a maximum of 12 inches (300 mm) above a floor drain or external to the building. In cold climates, it is recommended that the discharge pipe be terminated at an adequate drain inside the building.
- Shall not have any shut-off valve between the relief valve and tank nor in the discharge pipe.

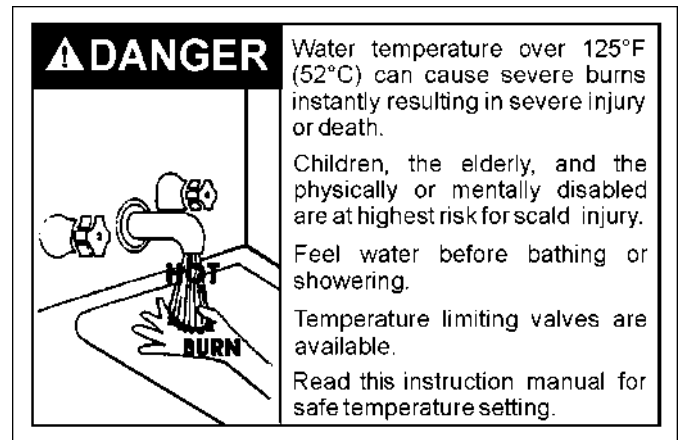

The temperature-pressure relief valve must be manually operated at least once a year. Caution should be taken to ensure that (1) no one is in front of or around the outlet of the temperature-pressure relief valve discharge line, and (2) the water manually discharged will not cause any bodily injury or property damage because the water may be extremely hot.

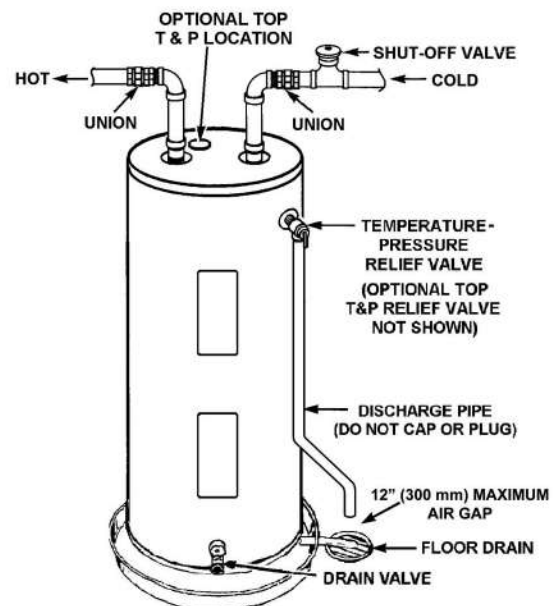

FIGURE 4.

If, after manually operating the valve, it fails to completely reset and continues to release water, immediately close the cold water inlet to the water heater, follow the draining instructions, and replace the temperature-pressure relief valve with a new one.

FILLING THE WATER HEATER

| |
|---|
| CAUTION |
| Property Damage Hazard |
| <ul style="list-style-type: none"> • Avoid damage to the water heater. • Fill tank with water before operating. |

Never use this water heater unless it is completely full of water. To prevent damage to the tank and heating element(s), the tank must be completely filled with water. Water must flow from the hot water faucet before turning "ON" electrical supply to the water heater. The manufacturer will not warrant any elements damaged by failure to follow instructions.

To fill the water heater with water:

1. Close the water heater drain valve by turning the handle to the right (clockwise). The drain valve is on the lower front of the water heater.
2. Open the cold water supply valve to the water heater. **NOTE: The cold water supply valve must be left open when the water heater is in use.**
3. To ensure complete filling of the tank, allow air to exit by opening the nearest hot water faucet. Allow water to run until a constant flow is obtained. This will let air out of the water heater and the piping.
4. Check all water piping and connections for leaks. Repair as needed.
5. Never alter or modify the certified construction of the water heater or its components, or bypass any safety features. Doing so voids all warranties.

T&P VALVE and PIPE INSULATION (On Selected Models)

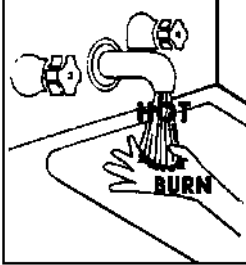
| | |
|--|---|
| ⚠ DANGER | <p>When a supplemental heat source such as a solar storage tank is connected to the water heater, a remote temperature control device should be installed in the water piping to limit water temperatures. The temperature setting of this control should not exceed that of the water heater thermostat setting. Failure to adjust both thermostats can cause loss of proper temperature control, and could potentially produce water temperature in excess of 180°F (82°C).</p> |
|  | |

1. Locate the temperature and pressure relief valve on the water heater (also known as a T&P relief valve). See Figure 5.
2. Locate the slit running the length of the T&P relief valve insulation.
3. Spread the slit open and fit the insulation over the T&P relief valve. See Figure 5. Apply gentle pressure to the insulation to ensure that it is fully seated on the T&P Relief Valve. Once seated, secure the insulation with duct tape, electrical tape, or equivalent. **IMPORTANT:** The insulation or tape must not block the discharge opening or hinder access to the manual relief lever (Figure 5). Ensure a discharge pipe is installed into the T&P valve discharge opening per the instructions in this manual.
4. Locate the hot water (outlet) & cold water (inlet) pipes to the water heater.
5. Locate the slit running the length of a section of pipe insulation.
6. Spread the slit open and slip the insulation over the cold water (inlet) pipe. Apply gentle pressure along the length of the insulation to ensure that it is fully seated around the pipe. Also, ensure that the base of the insulation is flush with the water heater. Once seated, secure the insulation with duct tape, electrical tape, or equivalent.
7. Repeat steps 5 and 6 for the hot water (outlet) pipe.
8. Add additional sections of pipe insulation as needed.

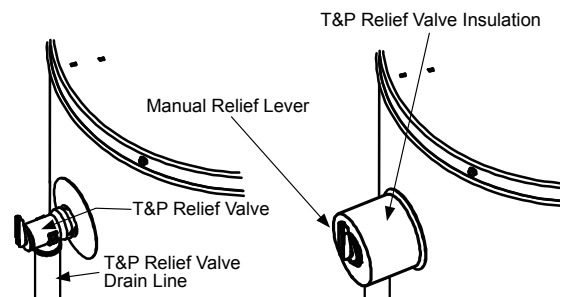

FIGURE 5.

WIRING DIAGRAMS

⚠ WARNING

- Before removing any access panels or servicing the water heater, make sure the electrical supply to the water heater is turned "OFF."
- Failure to do this could result in death, serious bodily injury, or property damage.

FOR ACTUAL WIRING CIRCUIT OF UNIT - REFERENCE CIRCUIT TYPE LISTED ON RATING PLATE.

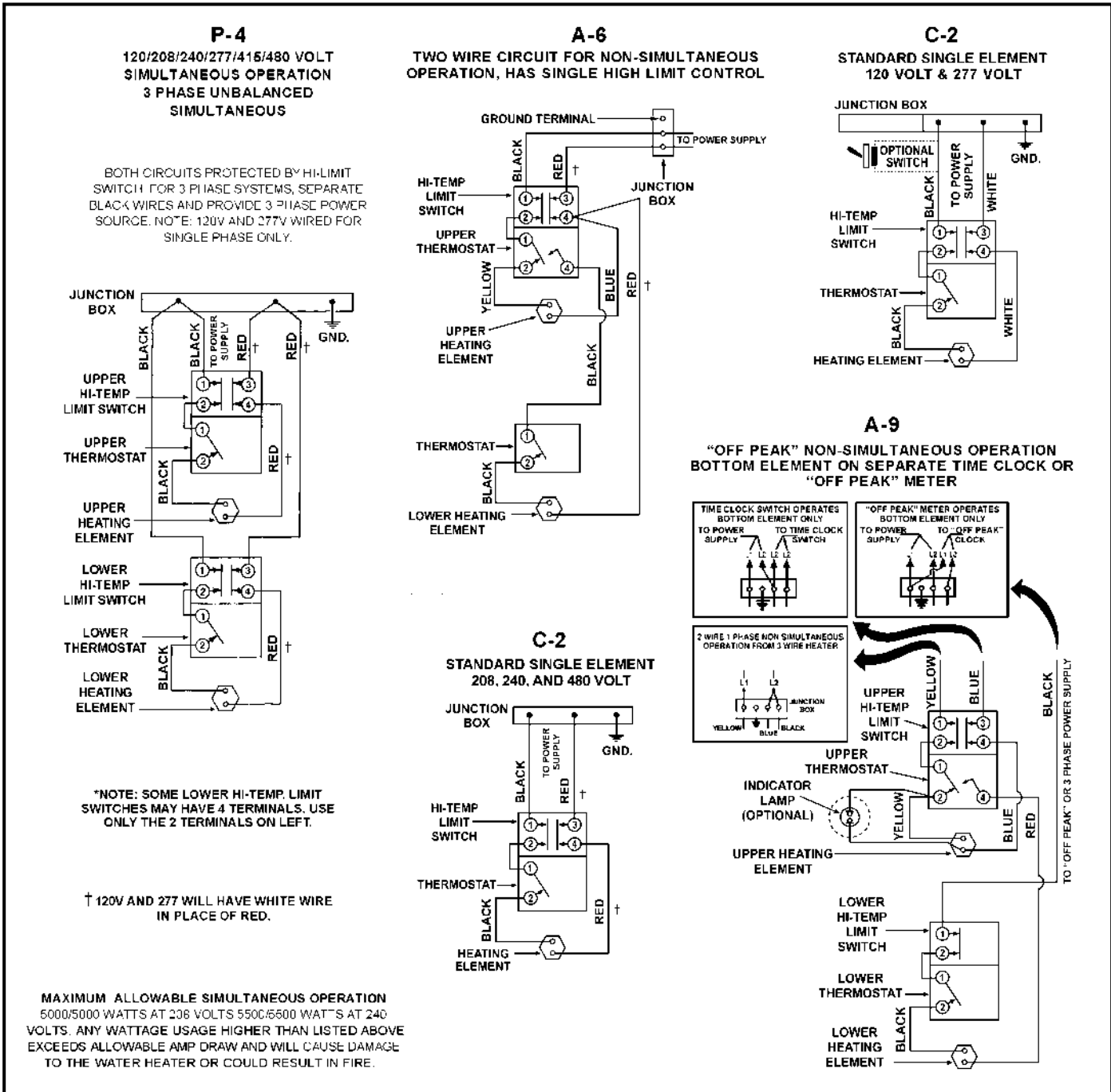

FIGURE 6.
11

WIRING

CAUTION

Improper installation and use may result in property damage.

- Fill tank with water before operation.

Never use water heater unless it is completely full of water. To prevent damage to the tank and heating elements, the tank must be completely filled with water. Water must flow uninterrupted from the hot water faucet before turning on power.

You must provide all wiring of the proper size outside of the water heater. You must obey local codes and electric company requirements when you install this wiring.

If you are not familiar with electric codes and practices, or if you have any doubt, even the slightest doubt, in your ability to connect the wiring to this water heater, obtain the service of a competent electrician. Contact a local electrical contractor and/or the local electric utility.

WARNING

Fire Hazard / Electric Shock Hazard



- Do not use this water heater with any voltage other than shown on the model rating plate.
- Failure to use the correct voltage shown on the model rating plate could result in death, serious bodily injury, or property damage.

WATER HEATERS EQUIPPED FOR ONE VOLTAGE ONLY: This water heater is equipped for one type voltage only. Check the rating plate on the front of the water heater for the correct voltage. DO NOT use this water heater with any voltage other than the one shown on the model rating plate. Failure to use the correct voltage can cause problems which can result in DEATH, SERIOUS BODILY INJURY, OR PROPERTY DAMAGE. If you have any questions or doubts consult your electric company.

If wiring from your fuse box or circuit breaker box was aluminum for your old water heater, replace it with copper wire. If you wish to reuse the existing aluminum wire, have the connection at the water heater made by a competent electrician. Contact a local electrical contractor and/or the local electric utility.

1. Provide a way to easily shut off the electric power when working on the water heater. This could be with a circuit breaker or fuse block in the entrance box or a separate disconnect switch.
2. Install and connect a circuit directly from the main fuse or circuit breaker box. This circuit must be the right size and have its own fuse or circuit breaker.
3. If metal conduit is used for the grounding conductor:
 - A. The grounding electrode conductor shall be of copper, aluminum, or copperclad aluminum. The material shall be of one continuous length without a splice or joint.
 - B. Rigid metal conduit, intermediate metal conduit, or electrical, metallic tubing may be used for the grounding means if conduit or tubing is terminated in fittings approved for grounding.
 - C. Flexible metal conduit or flexible metallic tubing shall be permitted for grounding if all the following conditions are met:
 - The length in any ground return path does not exceed 6 feet.
 - The circuit conductors contained therein are protected by overcurrent devices rated at 20 amperes or less.
 - The conduit or tubing is terminated in fittings approved for grounding.

For complete grounding details and all allowable exceptions, refer to the current edition of the Canadian Electrical Code CSA C22.1.

4. A standard 1/2" conduit opening has been made in the water heater junction box for the conduit connections.
5. Use wire nuts and connect the power supply wiring to the wires inside the water heater's junction box.
6. The water heater must be electrically "grounded" by the installer. A green ground screw has been provided on the water heater's junction box. Connect ground wire to this location.
7. Replace the wiring junction cover using the screw provided.

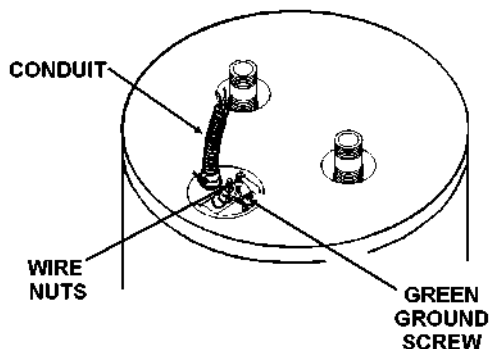
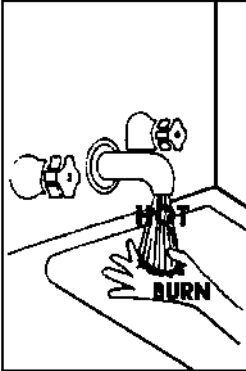

FIGURE 7.

TEMPERATURE REGULATION



⚠ DANGER Water temperature over 125°F (52°C) can cause severe burns instantly resulting in severe injury or death.

Children, the elderly, and the physically or mentally disabled are at highest risk for scald injury.

Feel water before bathing or showering.

Temperature limiting valves are available.

Read this instruction manual for safe temperature setting.

HOTTER WATER CAN SCALD: Water heaters are intended to produce hot water. Water heated to a temperature which will satisfy space heating, clothes washing, dish washing, and other sanitizing needs can scald and permanently injure you upon contact. Some people are more likely to be permanently injured by hot water than others. These include the elderly, children, the infirm, or physically/mentally disabled. If anyone using hot water in your home fits into one of these groups or if there is a local code or state law requiring a certain temperature water at the hot water tap, then you must take special precautions. In addition to using the lowest possible temperature setting that satisfies your hot water needs, a means such as a mixing valve should be used at the hot water taps used by these people or at the water heater. Mixing valves are available from your local plumbing contractor. Follow manufacturer's instructions for installation of the valves. Before changing the factory setting on the thermostat, see Figure 8.

Never allow small children to use a hot water tap or to draw their own bath water. Never leave a child or handicapped person unattended in a bathtub or shower.

It is recommended that lower water temperatures be used to avoid the risk of scalding. It is further recommended, in all cases, that the water temperature thermostat be set for the lowest temperature which satisfies your hot water needs. This will also provide the most energy efficient operation of the water heater. Thermostat(s) are factory set at 140°F (60°C) unless specified differently by provincial requirements.

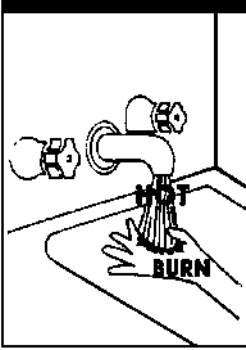

⚠ DANGER When a supplemental heat source such as a solar storage tank is connected to the water heater, a remote temperature control device should be installed in the water piping to limit water temperatures. The temperature setting of this control should not exceed that of the water heater thermostat setting. Failure to adjust both thermostats can cause loss of proper temperature control, and could potentially produce water temperature in excess of 180°F (82°C).

WATER TEMPERATURE OVER 125°F (52°C) CAN CAUSE SEVERE BURNS INSTANTLY OR DEATH FROM SCALDS.

Figure 8 shows the approximate time-to-burn relationship for normal adult skin.

TEMPERATURE ADJUSTMENT



⚠ WARNING

- Before removing any access panels or servicing the water heater, make sure the electrical supply to the water heater is turned "OFF."
- Failure to do this could result in death, serious bodily injury, or property damage.

To change the temperature setting:

NOTE: It is not necessary to adjust the upper thermostat. However, if it is adjusted above the factory set point (140°F (60°C)) it is recommended that it not be set higher than the lower thermostat setting.

1. Turn off the heater electrical supply. Do not attempt to adjust thermostat with power on.
2. Remove the thermostat access panel(s) and fold up the insulation to expose the thermostats. Do not remove the plastic personnel protectors covering the thermostats.
3. Using a flat tip screwdriver, rotate the adjustment knob to the desired temperature setting.
4. Replace the insulation and access panels and turn on heater electrical supply.

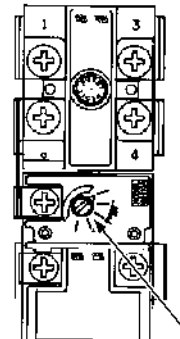

ADJUSTABLE UPPER THERMOSTAT BEHIND UPPER ACCESS PANEL (DUAL ELEMENT MODELS ONLY)

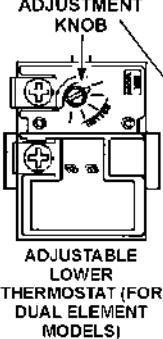

TEMPERATURE ADJUSTMENT KNOB

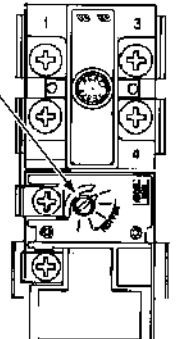

ADJUSTABLE LOWER THERMOSTAT WITH HIGH LIMIT

TEMPERATURE SETTINGS

It is recommended that the dial be set lower whenever possible.

| Temperature Setting | Time to Produce 2nd & 3rd Degree Burns on Adult Skin |
|---------------------|--|
| 160°F (71°C) | About 1/2 second |
| 150°F (66°C) | About 1-1/2 seconds |
| 140°F (60°C) | Less than 5 seconds |
| 130°F (54°C) | About 30 seconds |
| 120°F (49°C) | More than 5 minutes |

FIGURE 8.

FOR YOUR INFORMATION

THERMAL EXPANSION

CAUTION

Property Damage Hazard

- Avoid water heater damage.
- Install thermal expansion tank or device if necessary.
- Contact qualified installer or service agency.

As water is heated, it expands (thermal expansion). In a closed system, the volume of water will grow. As the volume of water grows, there will be a corresponding increase in water pressure due to thermal expansion. Thermal expansion can cause premature tank failure (leakage). This type of failure is not covered under the limited warranty. Thermal expansion can also cause intermittent temperature-pressure relief valve operation: water discharged from the valve due to excessive pressure build up. The temperature-pressure relief valve is not intended for the constant relief of thermal expansion. This condition is not covered under the limited warranty.

A properly-sized thermal expansion tank should be installed on all closed systems to control the harmful effects of thermal expansion. Contact a plumbing service agency or your retail supplier regarding the installation of a thermal expansion tank.

STRANGE SOUNDS

Possible noises due to expansion and contraction of some metal parts during periods of heat-up and cool-down do not necessarily represent harmful or dangerous conditions.

OPERATIONAL CONDITIONS

WATER ODOR

In each water heater there is installed at least one anode rod (see parts sections) for corrosion protection of the tank. Certain water conditions will cause a reaction between this rod and the water. The most common complaint associated with the anode rod is one of a "rotten egg smell" in the hot water. This odor is derived from hydrogen sulfide gas dissolved in the water. The smell is the result of four factors which must all be present for the odor to develop:

- A. A concentration of sulfate in the supply water.
- B. Little or no dissolved oxygen in the water.
- C. A sulfate reducing bacteria which has accumulated within the water heater (this harmless bacteria is nontoxic to humans).
- D. An excess of active hydrogen in the tank. This is caused by the corrosion protective action of the anode.

Smelly water may be eliminated or reduced in some water heater models by replacing the anode(s) with one of less active material, and then chlorinating the water heater tank and all hot water lines. Contact the local water heater supplier or service agency for further information concerning an Anode Replacement Kit and this chlorination treatment. If the smelly water persists after the anode replacement and chlorination treatment, we can only suggest that chlorination or aeration of the water supply be considered to eliminate the water problem.

Do not remove the anode leaving the tank unprotected. By doing so, all warranty on the water heater tank is voided.

"AIR" IN HOT WATER FAUCETS

WARNING

Explosion Hazard

- Flammable hydrogen gases may be present.
- Keep all ignition sources away from faucet when turning on hot water.

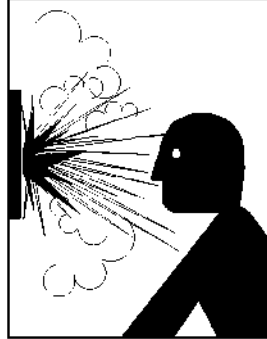

HYDROGEN GAS: Hydrogen gas can be produced in a hot water system that has not been used for a long period of time (generally two weeks or more). Hydrogen gas is extremely flammable and explosive. To prevent the possibility of injury under these conditions, we recommend the hot water faucet, located farthest away, be opened for several minutes before any electrical appliances which are connected to the hot water system are used (such as a dishwasher or washing machine). If hydrogen gas is present, there will probably be an unusual sound similar to air escaping through the pipe as the hot water faucet is opened. There must be no smoking or open flame near the faucet at the time it is open.

HIGH WATER TEMPERATURE SHUT OFF SYSTEM

A non-adjustable high temperature limit control operates before steam temperatures are reached. The high limit is in the same area as the upper thermostat and must be reset manually when it operates. **BECAUSE THE HIGH LIMIT OPERATES ONLY WHEN ABNORMALLY HIGH WATER TEMPERATURES ARE PRESENT, IT IS IMPORTANT THAT A QUALIFIED SERVICE AGENT BE CONTACTED TO DETERMINE THE REASON FOR OPERATION BEFORE RESETTING.**

WARNING

- Before removing any access panels or servicing the water heater, make sure the electrical supply to the water heater is turned "OFF."
- Failure to do this could result in death, serious bodily injury, or property damage.



- Turn off the heater electrical supply. Do not attempt to reset thermostat with power on.
- Remove the screw securing the outer door and remove door.
- Remove or fold up the insulation to expose the reset button.
- Reset the high limit by pushing in the red button marked "RESET".
- Replace the insulation so that it completely covers the thermostat and element.
- Replace the outer door.
- Turn "ON" electric power to the water heater.

PERIODIC MAINTENANCE

ANODE ROD INSPECTION AND REPLACEMENT

CAUTION

Property Damage Hazard

- Avoid water heater damage.
- Inspection and replacement of anode rod required.

Each water heater contains at least one anode rod, which will slowly deplete (due to electrolysis), prolonging the life of the water heater by protecting the glass-lined tank from corrosion. Adverse water quality, hotter water temperatures, high hot water usage, and water softening methods can increase the rate of anode rod depletion. Once the anode rod is depleted, the tank will start to corrode, eventually developing a leak.

Certain water conditions will cause a reaction between the anode rod and the water. The most common complaint associated with the anode rod is a "rotten egg smell" produced from the presence of hydrogen sulfide gas dissolved in the water. **IMPORTANT:** Do not remove this rod permanently as it will void any warranties. A special anode rod may be available if water odor or discoloration occurs. **NOTE:** This rod may reduce but not eliminate water odor problems. The water supply system may require special filtration equipment from a water conditioning company to successfully eliminate all water odor problems.

Artificially softened water is exceedingly corrosive because the process substitutes sodium ions for magnesium and calcium ions. The use of a water softener may decrease the life of the water heater tank.

The anode rod should be removed from the water heater tank every 3 years for inspection. **NOTE:** Artificially softened water requires the anode rod to be inspected annually.

The following are typical (but not all) signs of a depleted anode rod:

- The majority of the rod's diameter is less than 3/8 inch (9.5 mm).
- Significant sections of the support wire (approx. 1/3 or more of the anode rod's length) are visible. If the anode rod shows signs of either or both, it should be replaced. **NOTE:** Whether re-installing or replacing the anode rod, check for any leaks and immediately correct if found.

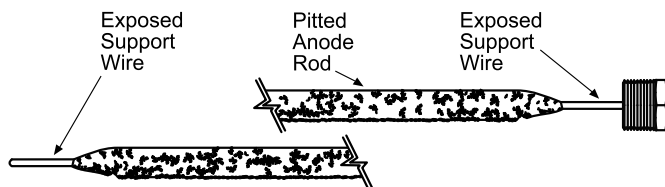

FIGURE 8A.

In replacing the anode:

1. Turn off power to the water heater.
2. Shut off the water supply and open a nearby hot water faucet to depressurize the water tank.
3. Drain approximately 5 gallons of water from tank. (Refer to "Draining and Flushing" for proper procedures). Close drain valve.
4. Remove old anode rod.
5. Use Teflon® tape or approved pipe sealant on threads and install new anode rod.
6. Turn on water supply and open a nearby hot water faucet to purge air from water system. Check for any leaks and immediately correct any if found.
7. Restart the water heater as directed in this manual. See the Repair Parts Illustration for anode rod location.

TEMPERATURE-PRESSURE RELIEF VALVE OPERATION

⚠ DANGER

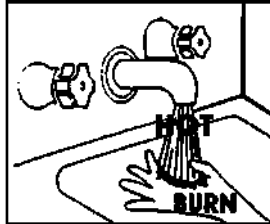

- Burn hazard
- Hot water discharge.
- Keep clear of relief valve discharge outlet.

The temperature-pressure relief valve must be manually operated at least once a year.

When checking the temperature-pressure relief valve operation, make sure that (1) no one is in front of or around the outlet of the temperature-pressure relief valve discharge line, and (2) that the water discharge will not cause any property damage, as the water may be extremely hot, see Figure 9.

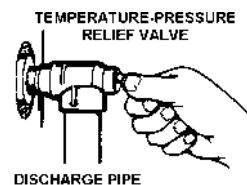

FIGURE 9.

If after manually operating the valve, it fails to completely reset and continues to release water, immediately close the cold water inlet to the water heater, follow the draining instructions, and replace the temperature-pressure relief valve with a new one.

If the temperature-pressure relief valve on the appliance weeps or discharges periodically, this may be due to thermal expansion. You may have a check valve installed in the water line or a water meter with a check valve. Consult your local water supplier or service agency for further information. Do not plug or remove the temperature-pressure relief valve.

DRAINING AND FLUSHING

⚠ DANGER

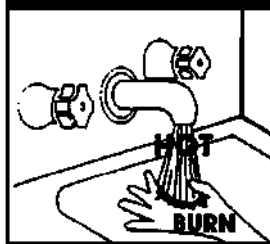

- Burn hazard
- Hot water discharge.
- Keep hands clear of drain valve discharge.

It is recommended that the tank be drained and flushed every 6 months to remove sediment which may build up during operation. The water heater should be drained if being shut down during freezing temperatures. To drain the tank, perform the following steps:

1. Turn off power to the water heater.
2. Open a nearby hot water faucet until the water is no longer hot.
3. Close the cold water inlet valve.
4. Connect a hose to the drain valve and terminate it to an adequate drain or external to the building.

- Open the water heater drain valve and allow all of the water to drain from the tank. Flush the tank with water as needed to remove sediment.
- Close the drain valve, refill the tank, and restart the heater as directed in this manual. **CAUTION:** Do not turn on power to the water heater unless it is completely filled with water.

If the water heater is going to be shut down for an extended period, the drain valve should be left open.

IMPORTANT: Condensation may occur when refilling the tank and should not be confused with a tank leak.

THERMOSTAT REMOVAL / REPLACEMENT

| | |
|---|--|
|  | <h3>⚠ WARNING</h3> <ul style="list-style-type: none"> • Before removing any access panels or servicing the water heater, make sure the electrical supply to the water heater is turned "OFF." • Failure to do this could result in death, serious bodily injury, or property damage. |
|---|--|

- Turn "OFF" the electric power supply to the water heater.
- Remove the outer door. Remove or fold up the insulation pad.
- A. **Models with lower thermostat without high limit:** Lift out the tab as shown below to unclip the terminal cover from the thermostat. The terminal cover can now be removed from the thermostat.

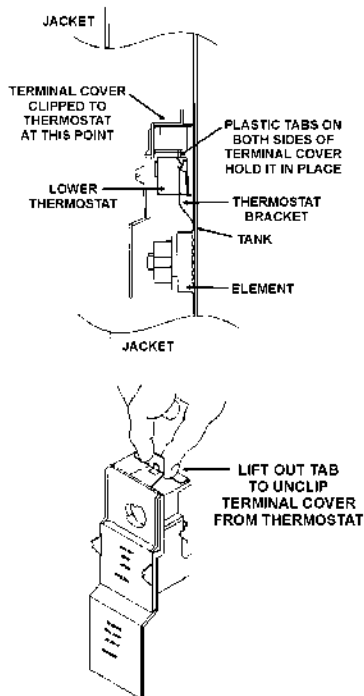

FIGURE 10.

- B. **Models with Upper or Lower Thermostat with High Limit:** Lift out the tab as shown below to unclip the terminal cover from the thermostat. The terminal cover can now be removed from the thermostat.

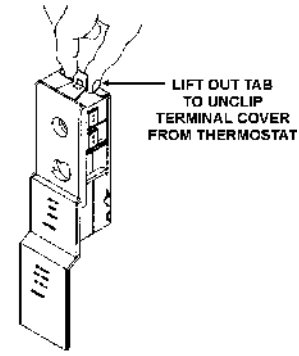

FIGURE 11.

- Note the position of each wire, then disconnect each wire from thermostat and slide out of the bracket.
- Remove the thermostat from behind the thermostat bracket.
- Place the new lower thermostat in the bracket making sure it fits firmly against the tank.
- Attach the wires to the new thermostat. Ensure that you install each wire in the correct terminal.

NOTE: Some of the terminals may require straight-in wiring through an eye-opening. If wires are now looped, recut and strip wire 3/8" (9.5 mm) to a straight length and insert.

- Put plastic terminal cover back in place.
- Replace the insulation to cover the thermostat.
- Replace outer door then turn the electric power on.

ELEMENT CLEANING / REPLACEMENT

NOTE: These instructions are written for element cleaning and element replacement for the lower element.

| | |
|--|--|
|  | <h3>⚠ WARNING</h3> <ul style="list-style-type: none"> • Before removing any access panels or servicing the water heater, make sure the electrical supply to the water heater is turned "OFF." • Failure to do this could result in death, serious bodily injury, or property damage. |
|--|--|

To remove the element from the tank in order to clean or replace it:

- Before beginning, turn "OFF" the electric power supply to the water heater.
- Open a nearby hot water faucet until the water is no longer hot.
- Turn off the water supply to the water heater at the water shut-off valve or water meter. See Figure 12.



FIGURE 12.

- Attach a hose to the water heater drain valve and put the other end in a floor drain or outdoors. Open the water heater drain

valve and allow the water heater to drain. Also, open a nearby hot water faucet to relieve the pressure in the water heater and to speed draining.

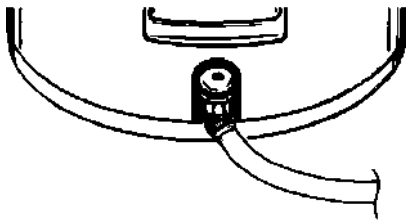

FIGURE 13.

The water passing out of the drain valve may be extremely hot. To avoid being scalded, make sure all connections are tight and that the water flow is directed away from any person.

5. Remove the screw securing the outer door, and remove door.

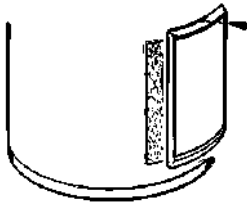

FIGURE 14.

6. Fold up the insulation to expose the thermostat terminal cover.

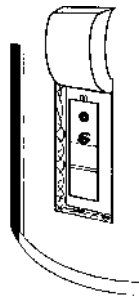

FIGURE 15.

7. A. **Models with lower thermostat without high limit:** Lift out the tab as shown below to unclip the terminal cover from the thermostat. The terminal cover can now be removed from the thermostat.

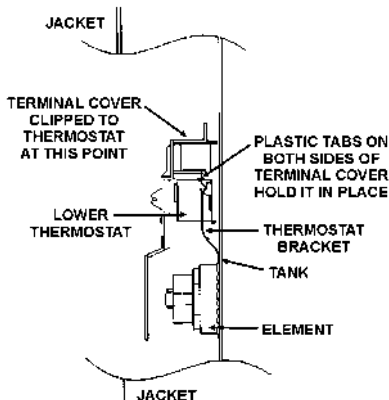

FIGURE 16A.

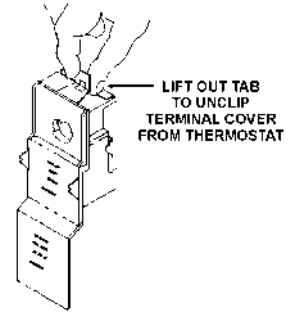

FIGURE 16B.

B. **Models with Upper or Lower Thermostat with High Limit:** Lift out the tab as shown below to unclip the terminal cover from the thermostat. The terminal cover can now be removed from the thermostat.

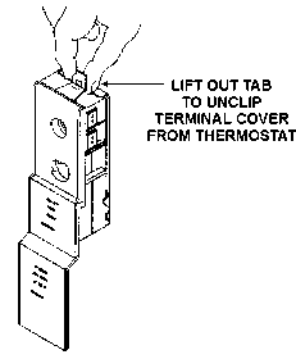

FIGURE 17.

8. Disconnect the two wires on the element and unscrew the old element from the tank.

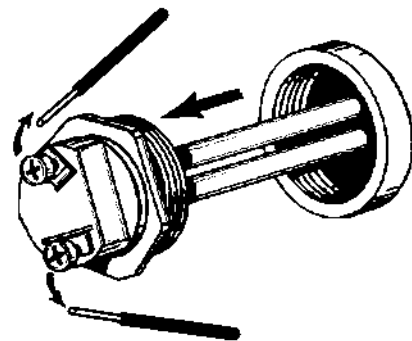

FIGURE 18.

9. Clean the area around the element opening. Remove any sediment from or around the element opening and inside the tank.

10. If you are cleaning the element you have removed, do so by scraping or soaking in vinegar or a deliming solution.

NOTE: Replacement elements must (1) be the same voltage and (2) no greater wattage than listed on the model rating plate affixed to the water heater.

11. A new gasket should be used in all cases to prevent a possible water leak. Place the new element gasket on the threaded side of the cleaned or new element and screw into tank, securing tightly using an element wrench.

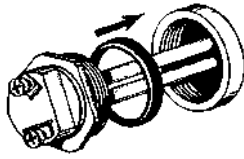

FIGURE 19.

12. Close the water heater drain valve by turning the handle to the right (clockwise). The drain valve is on the lower front of the water heater.

13. Open the cold water supply valve to the water heater.

NOTE: The cold water supply valve must be left open when the water heater is in use.

14. To ensure complete filling of the tank, allow air to exit by opening the nearest hot water faucet. Allow water to run until a constant flow is obtained. This will let air out of the water heater and the piping.

CAUTION

Improper installation and use may result in property damage.

- Fill tank with water before operation.

Never use this water heater unless it is completely full of water. To prevent damage to the tank and heating element, the tank must be filled with water. Water must flow from the hot water faucet before turning "ON" power. The manufacturer will not warrant any elements damaged by failure to follow instructions.

15. Check element for water leaks. If leakage occurs, tighten element or repeat Steps 2 and 3, remove element and reposition gasket. Then repeat Steps 10 through 14.

16. Reconnect the two wires to the element and then check to make sure the thermostat remains firmly against the surface of the tank.



FIGURE 20.

17. Replace terminal cover on thermostat making sure the locking tabs on the terminal cover are in place.

18. Fold down the insulation so that it covers the thermostat and element. See Figure 21.

19. Replace outer door.

20. Turn "ON" electric power to water heater.

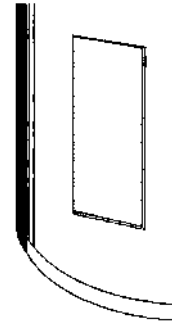

FIGURE 21.

DRAIN VALVE WASHER REPLACEMENT

(See Figure 22)

1. Follow the "Draining and Flushing" instructions.
2. Turning counter clockwise (↺), remove the hex cap below the screw handle.
3. Remove the washer and put the new one in place.
4. Screw the handle and cap assembly back into the drain valve and retighten using a wrench. **DO NOT OVER TIGHTEN.**
5. Follow instructions in the "Filling The Water Heater" section.
6. Check for leaks.

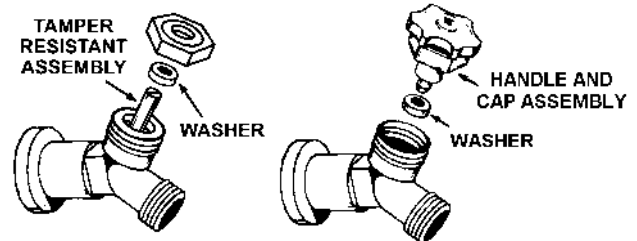

FIGURE 22.

SERVICE

If a condition persists or you are uncertain about the operation of the water heater contact a service agency.

LEAKAGE CHECKPOINTS

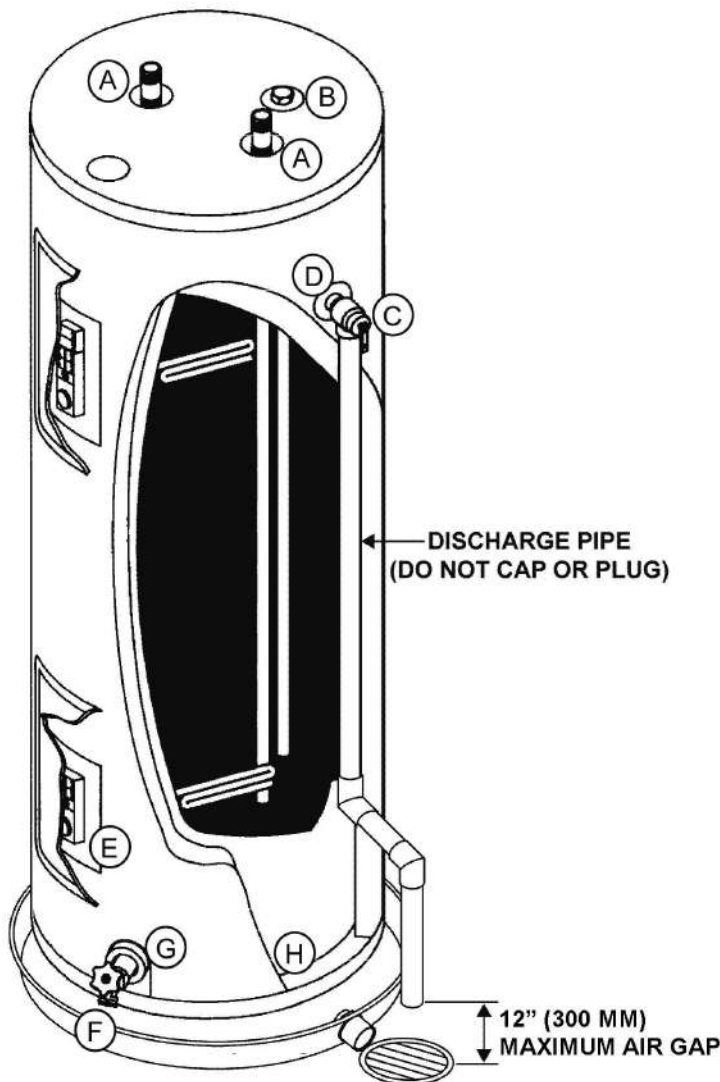
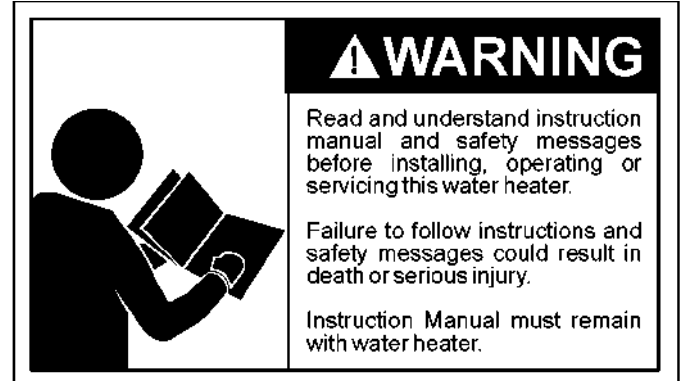

FIGURE 23.



Use this guide to check a “Leaking” water heater. Many suspected “Leakers” are not leaking tanks. Often the source of the water can be found and corrected.

If you are not thoroughly familiar with your water heater and safety practices, contact a qualified installer to check the water heater.



Read this manual first. Make sure the electrical power supply has been turned “OFF” before checking the tank for leakage.

- *A. Condensation and dripping may be seen on pipes if the water temperature is low in humid weather or pipe connections may be leaking.
- *B. The anode rod fitting may be leaking.
- C. Small amounts of water from temperature-pressure relief valve may be due to thermal expansion or high water pressure in your area. If the valve is not piped to an open drain the released water could be mistaken for a leaking heater, see “Thermal Expansion” section.
- *D. The temperature-pressure relief valve may be leaking at the tank fitting.
- E. Water on the side of the tank may be condensation due to the panel or insulation not being in place.
- F. Water from a drain valve may be due to the valve being slightly opened.
- *G. The drain valve may be leaking at the tank fitting.
- *H. Water in the water heater bottom or on the floor may be from condensation, loose connections, or the relief valve. DO NOT replace the water heater until a full inspection of all possible water sources is made and necessary corrective steps taken.

Leakage from other appliances, water lines, or ground seepage should also be checked.

- * To check where threaded portion enters tank, insert cotton swab between jacket opening and fitting. If cotton is wet, follow “Draining” instructions in the “Periodic Maintenance” section and then remove fitting. Put pipe dope or teflon tape on the threads and replace. Then follow “Filling the Water Heater” instructions in the “Installing the New Water Heater” section.

TROUBLESHOOTING GUIDELINES

These guidelines should be utilized by a qualified service agent.

| Problem | Possible Cause(s) | Corrective Action |
|--|--|--|
| WATER LEAKS (See Leakage Checkpoints on page 19) | Improperly sealed, hot or cold supply connection, relief valve or drain valve. | Seal and tighten threaded connections. |
| | Leakage from other appliances or water lines. | Inspect other appliances near water heater. |
| NO HOT WATER | No power to heater. | Turn on electrical switch. Check for blown fuses or tripped breaker. |
| | Non-functioning upper element. | Replace element. |
| | High Temperature Limit Switch open. | Reset. Check for source of trouble and correct. |
| | Non-functioning upper thermostat. | Replace thermostat. |
| INSUFFICIENT HOT WATER | Non-functioning thermostats. | Replace thermostats. |
| | Non-functioning lower element. | Replace element. |
| | Improper calibration. | Replace thermostats. |
| | Thermostats set too low. | Set thermostats to desired temperature. |
| | Sediment or lime in tank. | Drain. Determine if water treatment is needed. |
| | Heater too small for job. | Install water heater of adequate capacity. |
| | Wrong piping connections. | Correct piping. |
| | Leaking faucets. | Repair faucets. |
| | Wasted hot water. | Review and reduce hot water consumption. |
| | Long runs of exposed pipe. | Insulate piping. |
| | Hot water piping on outside wall. | Insulate piping. |
| HIGH OPERATION COSTS | Improper Calibration. | Replace thermostats. |
| | Thermostats set too high. | Set thermostat to desired setting. |
| | Sediment or lime in tank. | Drain. Flush-Provide water treatment if needed. |
| | Heater too small for job. | Install water heater of adequate capacity. |
| | Wrong piping connections. | Correct piping. |
| | Leaking faucets. | Repair faucets. |
| | Wasted hot water. | Review and reduce hot water consumption. |
| | Long runs of exposed piping. | Insulate piping. |
| | Hot water piping in exposed wall. | Insulate piping. |
| SLOW HOT WATER RECOVERY | Non-functioning upper element. | Replace element. |
| | Non-functioning lower element. | Replace element. |
| DRIP FROM RELIEF VALVE | Excessive water pressure. | Use Pressure Reducing Valve and Pressure Relief Valve. |
| | Closed system. | See "Thermal Expansion" in the For Your Information section. |
| THERMOSTAT DOES NOT SHUT OFF | Non-functioning thermostats. | Replace thermostats. |
| | Improper calibration. | Replace thermostats. |
| WATER ODOR | Sulfides in the water. | See "Operational Conditions" in the For Your Information section. |
| WATER HEATER SOUNDS | Scale accumulation on elements. | Contact dealer to clean or replace elements. |

REPAIR PARTS LIST

LOWBOY AND UPRIGHT ELECTRIC MODELS (Single and Dual Element)

| Key No. | Part Description |
|---------|--|
| 1 | Temperature-Pressure Relief Valve |
| 2 | Secondary Anode Rod/Nipple w/Heat Trap* |
| 3 | Element w/Gasket |
| 4 | Element Gasket |
| 5 | Lower Outer Door |
| 6 | Terminal Cover (Double Element) |
| 7 | Upper Thermostat w/Hi Limit (Double Element) |
| 8 | Terminal Cover |
| 9 | Lower Thermostat w/Hi Limit |
| 10 | Terminal Cover |
| 11 | Lower Thermostat |
| 12 | Thermostat Bracket (ea.) |
| 13 | Drain Valve |
| 14 | Primary Anode |
| 15 | Dip Tube |
| 16 | Nipple w/Heat Traps* |
| 17 | Upper Outer Door |
| 18 | Metal Drain Pan w/Side Drain |
| 19 | Pipe Insulation* |
| 20 | T & P Insulation* |
| ** | Instruction Manual |

* If Applicable

** Not Illustrated

Now that you have purchased this water heater, should a need ever exist for repair parts or service, simply contact the company it was purchased from or the manufacturer listed on the rating plate on the water heater.

Be sure to provide all pertinent facts when you call or visit.

Selling prices will be furnished on request or parts will be shipped at prevailing prices and you will be billed accordingly.

The model number of your Water Heater will be found on the rating plate located above or adjacent to outer door.

WHEN ORDERING REPAIR PARTS, ALWAYS GIVE THE FOLLOWING INFORMATION:

- MODEL NUMBER
- SERIAL NUMBER
- VOLTAGE AND ELEMENT WATTAGE
- PART DESCRIPTION

THIS IS A REPAIR PARTS LIST, NOT A PACKING LIST.

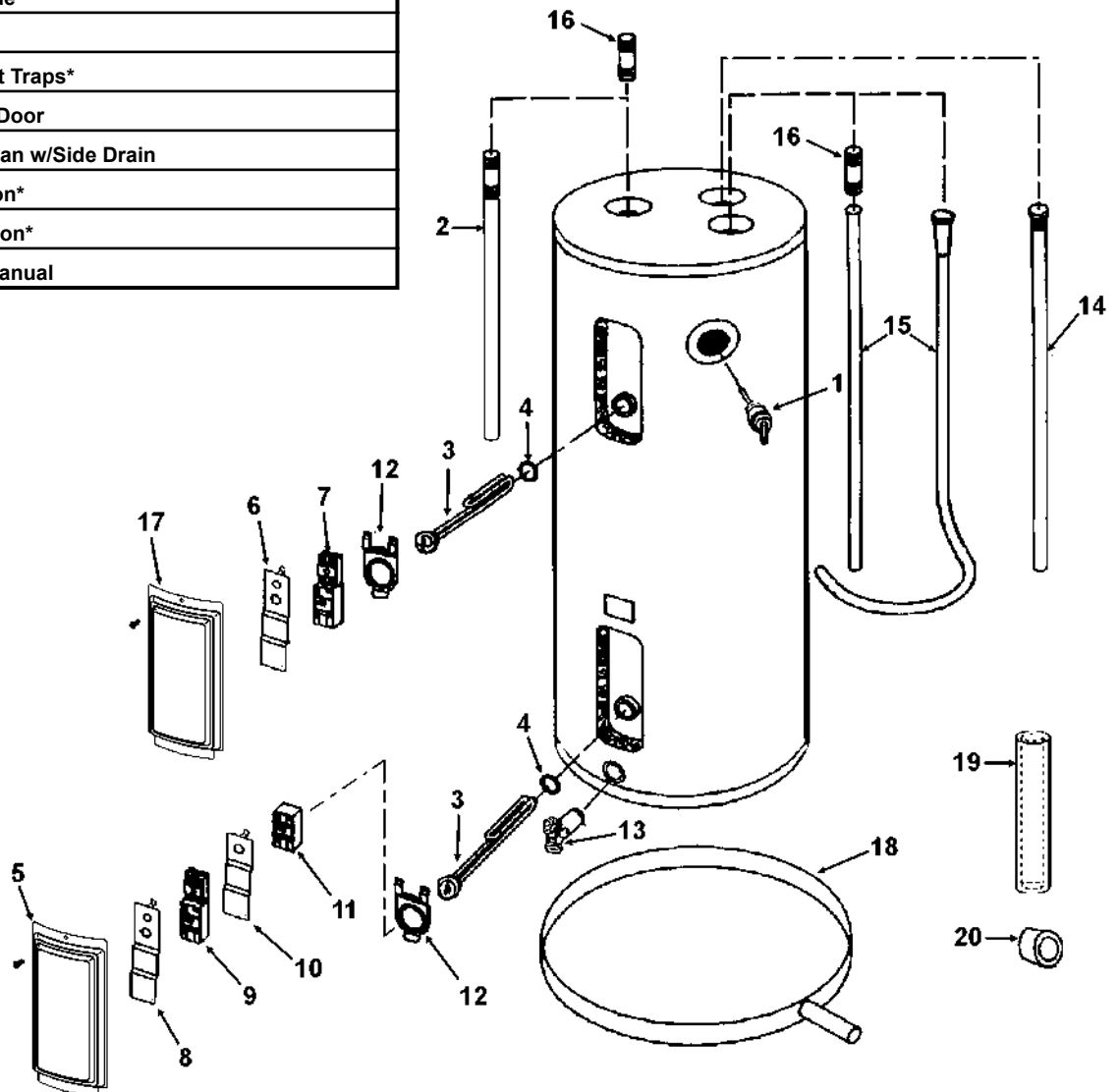

REPAIR PARTS LIST

COMPACT OR MANUFACTURED (MOBILE) HOME ELECTRIC MODELS

| Key No. | Part Description | | |
|---------|-----------------------------------|----|------------------------------|
| 1 | Temperature-Pressure Relief Valve | 13 | Upper Outer Door |
| 2 | Outlet Nipple Assembly | 14 | Upper Thermostat w/Hi/Limit |
| 3 | Inlet Nipple | 15 | Anode Rod |
| 4 | Junction Box Cover | 16 | Drain Valve |
| 5 | Upper and Lower Element | 17 | Metal Drain Pan w/Side Drain |
| 6 | Element Gasket | 18 | Conduit Bracket |
| 7 | Thermostat Bracket (ea.) | 19 | Pipe Insulation* |
| 8 | Lower Thermostat | 20 | T & P Insulation* |
| 9 | Terminal Cover | 21 | Dip Tube |
| 10 | Lower Thermostat w/Hi Limit | 22 | Plug |
| 11 | Terminal Cover | ** | Instruction Manual |
| 12 | Lower Outer Door | | |

* If Applicable
 ** Not Illustrated

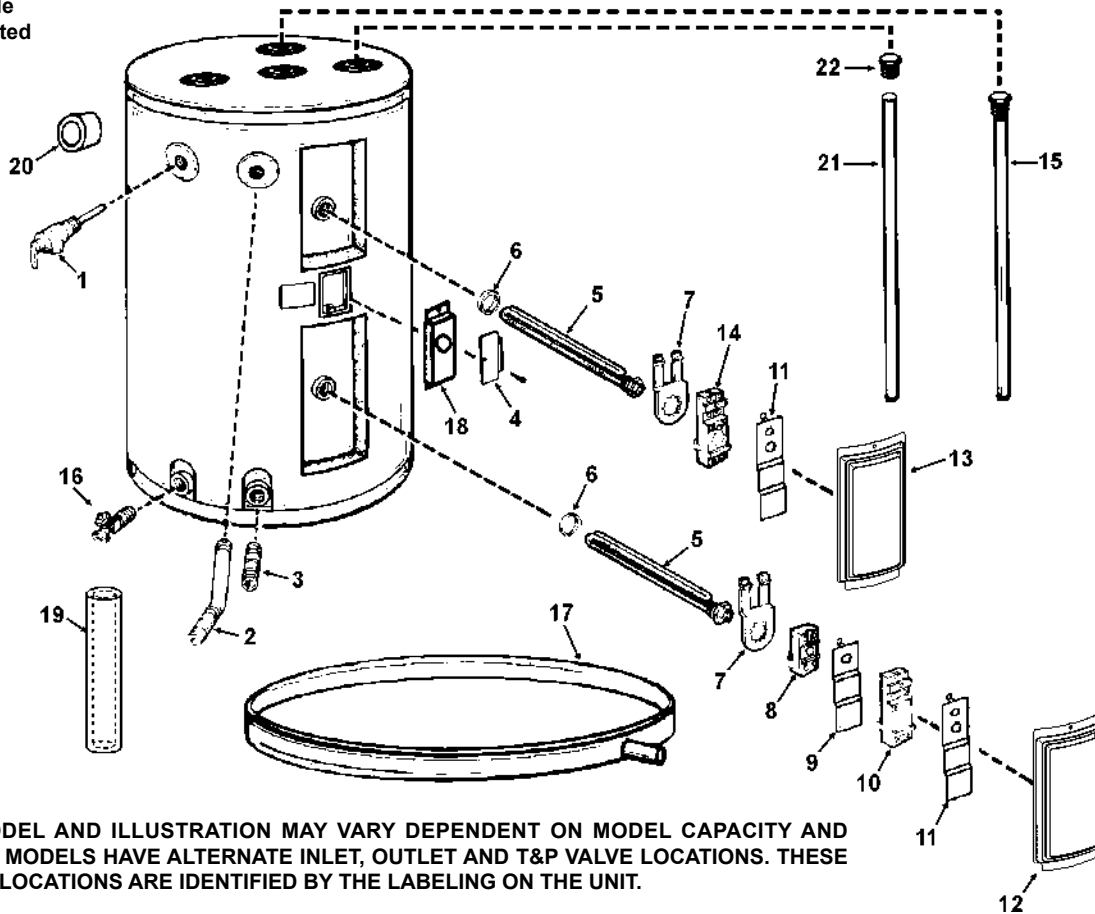

ACTUAL MODEL AND ILLUSTRATION MAY VARY DEPENDENT ON MODEL CAPACITY AND TYPE. SOME MODELS HAVE ALTERNATE INLET, OUTLET AND T&P VALVE LOCATIONS. THESE ALTERNATE LOCATIONS ARE IDENTIFIED BY THE LABELING ON THE UNIT.

Now that you have purchased this water heater, should a need ever exist for repair parts or service, simply contact the company it was purchased from or the manufacturer listed on the rating plate on the water heater.

Be sure to provide all pertinent facts when you call or visit.

Selling prices will be furnished on request or parts will be shipped at prevailing prices and you will be billed accordingly.

The model number of your Water Heater will be found on the rating plate located above or adjacent to outer door.

WHEN ORDERING REPAIR PARTS, ALWAYS GIVE THE FOLLOWING INFORMATION:

- MODEL NUMBER
- SERIAL NUMBER
- VOLTAGE AND ELEMENT WATTAGE
- PART DESCRIPTION

THIS IS A REPAIR PARTS LIST, NOT A PACKING LIST.

REPAIR PARTS LIST

TABLE TOP ELECTRIC MODELS

| Key No. | Part Description |
|---------|---------------------------------------|
| 1 | Porcelain Top |
| 2 | Temperature and Pressure Relief Valve |
| 3 | Primary Anode Rod |
| 4 | Upper Thermostat w/Hi Limit |
| 5 | Dip Tube |
| 6 | Element w/Gasket |
| 7 | Element Gasket |
| 8 | Thermostat Bracket (ea.) |
| 9 | Terminal Cover |
| 10 | Outer Door (ea.) |
| 11 | Lower Thermostat w/Hi Limit |
| 12 | Terminal Cover |
| 13 | Lower Thermostat |
| 14 | Drain Access Door |
| 15 | Drain Valve |
| 16 | Toe Panel |
| ** | Instruction Manual |

** Not Illustrated

Now that you have purchased this water heater, should a need ever exist for repair parts or service, simply contact the company it was purchased from or the manufacturer listed on the rating plate on the water heater.

Be sure to provide all pertinent facts when you call or visit.

Selling prices will be furnished on request or parts will be shipped at prevailing prices and you will be billed accordingly.

The model number of your Water Heater will be found on the rating plate located under or adjacent to outer door.

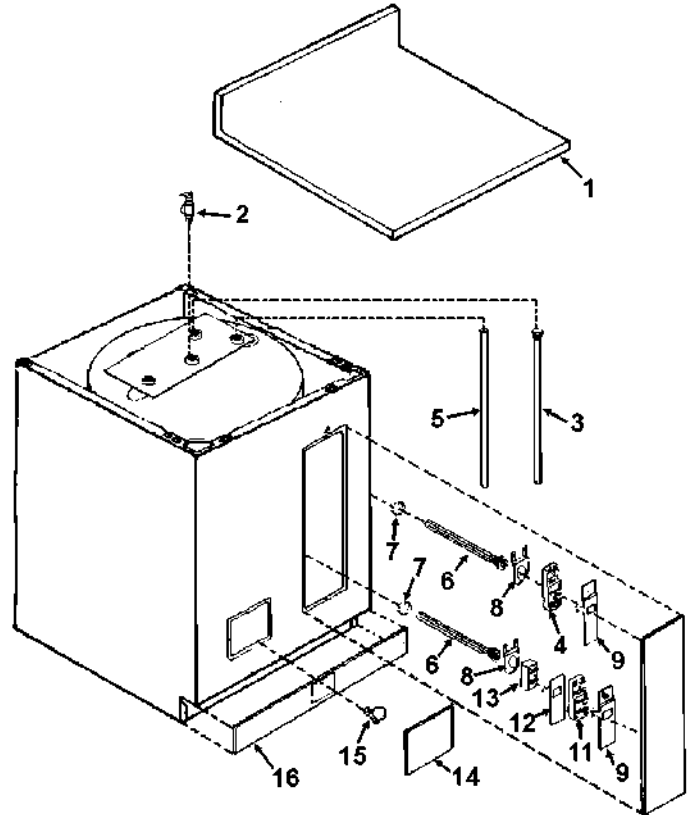

WHEN ORDERING REPAIR PARTS, ALWAYS GIVE THE FOLLOWING INFORMATION:

- MODEL NUMBER
- SERIAL NUMBER
- VOLTAGE AND ELEMENT WATTAGE
- PART DESCRIPTION

THIS IS A REPAIR PARTS LIST, NOT A PACKING LIST.

LIMITED WARRANTY

When referencing the water heater for service or warranty, please refer to the rating plate affixed to the unit. The Model Number contains the warranty period. Example: JW850SDEB

| | |
|-------------------------------|-----------|
| | JW |
| Inner Tank Warranty Years | 8 |
| Component Part Warranty Years | 6 |

The Serial Number contains the manufacture date information for the unit as follows:

Example: 1005 F001234

← Manufactured in week 5
← Manufactured in 2010

RESIDENTIAL STORAGE TANK TYPE WATER HEATER FOR INSTALLATION IN A SINGLE FAMILY DWELLING

A. WHO IS COVERED.

GSW WATER HEATING AND ITS SUPPLIERS, (herein collectively referred to as "Manufacturer") warrants only to the original consumer purchaser (hereinafter "Owner") of the water heater, within the boundaries of the continental United States or Canada, or their territories, so long as he or she continuously occupies the single family dwelling in which this water heater is initially installed for the period specified below. This Warranty is not transferable. This Warranty is reduced to one year if the water heater is used in a commercial or industrial application, or if the water heater is used to supply more than one dwelling unit. Consumers must retain point-of-sale proof of purchase to validate warranty entitlement.

B. WHEN IT IS COVERED.

The water heater is warranted only when it is installed, operated, and maintained in accordance with the printed instructions accompanying the water heater. The water heater shall/must be installed in such a manner that, if the tank or any connection thereto should leak, the resulting flow of water will not cause damage to the area in which it is installed. The water heater's temperature and pressure relief valve must be piped to the nearest drain to avoid damage in the event the valve is actuated. For detailed instructions, read the manual accompanying the water heater and review drawings in the manual.

C. WHAT THE MANUFACTURER WILL DO AND THE PERIOD OF COVERAGE.

1. The Inner Tank. If the inner tank leaks within the warranty period shown in the table above after the original installation, the Manufacturer will furnish a new water heater of the Manufacturer's then prevailing comparable model. If industry standards, regulatory changes, product improvements, or product obsolescence prohibits the Manufacturer from furnishing an identical model replacement water heater under this Warranty, the Owner will be furnished with a new water heater of comparable capacity; however, the Owner will be charged for the additional value of the item(s) which the Manufacturer has incorporated in the replacement water heater. A prior authorization number must be obtained from the Manufacturer before replacing the water heater. This Warranty is limited to one replacement water heater at the original installation site.
2. Component Part. If any component, part other than the inner tank, proves to the Manufacturer's satisfaction to be defective in material or workmanship within the warranty period shown in the table above after the original installation, the Manufacturer will furnish the Owner with a replacement for the defective part(s). This Warranty is limited to one replacement component part for each original part.
3. Return of Defective Water Heater and Component Parts. The Manufacturer reserves the right to examine the alleged defect in the water heater or component part(s). As such, it will be the Owner's obligation (see paragraph D. 3) to return the water heater and/or component part(s) to the Manufacturer.
 - a. When returning a water heater, it must include all component parts and the rating plate label.
 - b. When returning component part(s), they must be individually tagged and identified with the water heater's Model Number, SKU, Serial Number, date of purchase, and date of installation.
 - c. THERE ARE NO WARRANTIES WHICH EXTEND BEYOND THE DESCRIPTION ON THE FACE HEREOF. THIS EXPRESS WARRANTY IS, WHERE PERMITTED BY LAW, IN LIEU OF AND EXCLUDES AND REPLACES ALL OTHER CONDITIONS, WARRANTIES, GUARANTEES, REPRESENTATIONS, OBLIGATIONS OR LIABILITIES OF THE MANUFACTURER OF ANY NATURE OR KIND, EXPRESS OR IMPLIED, HOWEVER ARISING (WHETHER BY CONTRACT, CONDUCT, STATEMENT, STATUTE, NEGLIGENCE, PRINCIPLES OF MANUFACTURER'S LIABILITY, OPERATION OF LAW, OR OTHERWISE) WITH RESPECT TO THE UNIT OR ITS FIRNESS FOR A PARTICULAR PURPOSE, METCHANTABILITY, INSTALLATION, OPERATION, REPAIR, OR REPLACEMENT. THE MANUFACTURER EXPRESSLY DISCLAIMS ANY AND ALL IMPLIED WARRANTIES. IN NO EVENT WILL THE MANUFACTURER'S LIABILITIES EXCEED THE COST OF THE DEFECTIVE PART(S) OR UNIT.

D. WHAT THIS WARRANTY DOES NOT COVER.

1. The Unit must not be installed where water damage can result from a leak, while provision(s) shall be made for directing any water escaping from the Unit to a properly operating drainpipe. As all units of this type may eventually leak, you must protect against any potential water damage. The Manufacturer accepts no responsibility for such damage, nor any incidental or consequential loss, nor damage(s) related thereto, suffered by the Owner of the Unit nor by any third party.
2. The Manufacturer shall not be liable under this Warranty and this Warranty shall be void and have no effect if the following events occur:
 - a. The water heater or any of its component parts have been subject to misuse, alteration, neglect, or accident; or
 - b. The water heater has not been installed in accordance with the applicable local plumbing and/or building code(s) and/or regulations or, in their absence, with the latest edition of the Natural Gas and Propane Installation Code, and/or the Canadian Electrical Code; or
 - c. The water heater is not installed, operated, and maintained in accordance with the Manufacturer's instructions, includ-

ing if the water heater has any additional aftermarket equipment introduced into the sealed system not approved by the Manufacturer; or

- d. The water heater or any of its component parts are damaged or fails from operation with an empty or partially empty tank (such as, but not limited to elements burned out in a dry tank); or
 - e. The water heater or any part has been under water; or
 - f. The water heater is exposed to highly corrosive atmospheric conditions. No warranty extends, for example, and without limitation of the foregoing, to Units exposed to: salts, chemicals, exhausts, pollutants, or contaminants; or
 - g. The water heater is not continuously supplied with potable water; or
 - h. The water heater replacement is requested for reasons of noise, taste, odour, discolouration, and/or rust; or
 - i. The water heater is operated at temperatures exceeding the maximum setting of the thermostat and/or high limit control provided by the Manufacturer, or at water pressures exceeding the pressure reading stated on the Unit; or
 - j. The water heater is operated without an operating anode; or
 - k. The water heater is supplied or operated with deionized water; or
 - l. The water heater is removed from its original installation location; or
 - m. The water heater is installed outdoors (this water heater is intended only for indoor installation); or
 - n. The water heater is converted, or is attempted to be converted, from one voltage or wattage to another, if an electric water heater, or from one gas type to another, if a gas water heater; or
 - o. The water heater has not been fired at the factory rated input and fuel for which it was factory built; or
 - p. The water heater or any of its component parts fail due to sediment build-up; or
 - q. The water heater does not have installed a properly operating temperature and pressure relief valve, certified to ANSI Z21.22/CSA "Requirements for Relief Valves for Hot Water Supply Systems"; or
 - r. The water heater or any of its component parts fail because of fire, floods, lightning, or any other act of God, or any other contingency beyond the control of the Manufacturer; or
 - s. The water heater is installed in a closed system without adequate provision for thermal expansion.
3. Except when specifically prohibited by the applicable law, the Owner, and not the Manufacturer, shall be liable for and shall pay for all charges for labour or other expenses incurred in the removal, repair, or replacement of the water heater or any component part(s) claimed to be defective or any expense incurred to remedy any defect in the product. Such charges may include, but are not necessarily limited to:
- a. All freight, shipping, handling, and delivery costs of forwarding a new water heater or replacement part(s) to the Owner.
 - b. All costs necessary or incidental in removing the defective water heater or component part(s) and installing a new water heater or component part(s).
 - c. Any material required to complete and/or permits required for the installation of a new water heater or replacement part(s), and
 - d. All costs necessary or incidental in returning the defective water heater or component part(s) to a location designated by the Manufacturer.
4. The terms of this Limited Warranty cannot be modified by any person, whether or not he/she claims to represent or act on behalf of the Manufacturer.

E. HOW THE ORIGINAL OWNER CAN MAKE A WARRANTY CLAIM.

1. The Owner should submit the warranty claim direct to the Manufacturer's Service Department, at the address or phone number listed below, and the Manufacturer will arrange for the handling of the claim.
2. Whenever any inquiry or request is made, be sure to include the water heater's Catalogue Number, Model Number, Serial Number, date of purchase, date of installation, and location of installation.

This Warranty and the Manufacturer's obligations shall be construed and determined in accordance with the laws of both the Province of Ontario, and of Canada in force therein. This Warranty does not affect specific legal rights of a consumer under applicable law, except to the extent that such rights may be waived or replaced, and the provisions hereof are deemed to be amended to the extent necessary. The unenforceability of any provision, in whole or in part, of this Certificate shall not affect the remaining provisions. Any and all repair and/or replacement of part(s) or Unit are the sole and exclusive remedy available against the Manufacturer.



John Wood Water Heaters

599 Hill Street West

Fergus, ON Canada N1M 2X1

Should you have any questions, please

Visit us online at www.johnwoodwaterheaters.com, or

E-mail us at techsupport@gsw-wh.com, or

Call our Technical Support line at 1 888 GSW TECH (479 8324)



John Wood Water Heaters
599 Hill Street West
Fergus, ON Canada N1M 2X1
Should you have any questions, please
Visit us online at www.johnwoodwaterheaters.com, or
E-mail us at techsupport@gsw-wh.com, or
Call our Technical Support line at 1 888 GSW TECH (479 8324)