



GSW WATER HEATING
 599 Hill Street West
 Fergus, ON, Canada N1M 2X1

ELECTRIC WATER HEATER INSTALLATION AND OPERATING INSTRUCTIONS

For Brands: GSW, John Wood, SpaceSaver, GSW Moffat

TABLE OF CONTENTS

I) Introduction4
 II) Safety4
 III) Installation4
 IV) Operation6
 V) Maintenance6
 Warranty11

PLEASE RETAIN THESE INSTRUCTIONS IN A SAFE LOCATION FOR FUTURE REFERENCE

Read and understand these instructions thoroughly before starting



⚠ WARNING:
 Improper installation, adjustment, alteration, service, or maintenance can cause injury or property damage. Refer to this manual. For assistance or additional information, consult a qualified installer, service agency, or the electric utility.

⚠ FOR YOUR SAFETY

- Do not store or use gasoline or other flammable vapors and liquids in the vicinity of this or any other appliance.
- Installation and service must be performed by a qualified installer, service agency or the electric utility.

⚠ WARNING:
 If the information in these instructions is not followed exactly, a fire or explosion may result causing property damage, personal injury or death.

IF YOU HAVE ANY INSTALLATION, PERFORMANCE OR OPERATIONAL QUESTIONS PLEASE CALL THE FOLLOWING NUMBER, PRIOR TO REMOVING THE WATER HEATER
 (if this is a rental water heater please contact the rental company)

1-888-GSW-TECH (1-888-479-8324)
 GSW Water Heating is a division of GSW Water Products Inc.

INSTALLATION RECORD

This water heater is protected by a multi-year warranty against leaks plus a one (1) year warranty on parts.
 Record key data here for future reference and prompt service:

Installed By / Purchased From:		
Installation Date:	Location of Electrical Switch or Circuit Protector:	
Model Number	Serial Number	
Watts	Watts	Watts-Total
Volts	P.S.I.	U.S. Gal.

This page intentionally left blank. May be used for notes or to record other installation information.

This page intentionally left blank. May be used for notes or to record other installation information.

I) INTRODUCTION

Thank you for purchasing this water heater. Properly installed and maintained, it will provide years of trouble free service.

The warranty on this water heater is in effect only when the water heater is installed and operated in accordance with these instructions. The manufacturer of this water heater will not be liable for any injury or property damage resulting from failure to comply with these instructions.

IMPORTANT:

This water heater must be installed strictly in accordance with the instructions enclosed, and local electrical, fuel and building codes. It is possible that connections to the water heater, or the water heater itself, may develop leaks. IT IS THEREFORE IMPERATIVE that the water heater be installed so that any leakage of the tank or related water piping is directed to an adequate drain in such a manner that it cannot damage the building, furniture, floor covering, adjacent areas, lower floors of the structure or other property subject to water damage. This is particularly important if the water heater is installed in a multi-story building, on finished flooring or carpeted surfaces. GSW WILL NOT ASSUME ANY LIABILITY for damage caused by water leaking from the water heater, pressure relief valve, or related fittings. Select a location as centralized within the piping system as possible. In any location selected, it is recommended that a suitable drain pan be installed under the water heater. This pan must limit the water level to a MAXIMUM depth of 45mm (1 3/4 in.) and have a diameter that is a minimum of 50mm (2 in.) greater than the diameter of the water heater. Suitable piping shall connect the drain pan to a properly operating floor drain. When used with a fuel-fired heater, this drain pan must not restrict combustion air flow.

CAUTION

Hydrogen gas can be produced in a hot water system served by this storage tank that has not been used for a long period of time (generally two (2) weeks or more). **Hydrogen gas is extremely flammable and can ignite when exposed to a spark or flame.** To reduce the risk of injury under these conditions, it is recommended that the hot water faucet be opened for several minutes at the kitchen sink before using any electrical appliance connected to the hot water system. Use caution in opening faucets. If hydrogen is present, there will probably be an unusual sound such as air escaping through the pipe as the water begins to flow. There should be no smoking or open flame near the faucet at the time it is open.

II) SAFETY

Relief Valve Requirements

Caution: To reduce the risk of excessive pressures and temperatures in this water heater, install temperature and pressure protective equipment required by local codes. It

should be no less than a combination temperature and pressure relief valve certified by a nationally recognized testing laboratory that maintains periodic inspection of production of listed equipment or materials, as meeting the latest edition of “Relief Valves for Hot Water Supply Systems”, CSA 4.4 in Canada, “Relief Valves and Automatic Gas Shutoff Devices for Hot Water Supply Systems”, ANSI Z21.22 in the U.S.A. This valve must be marked with a maximum set pressure not to exceed the marked MAXIMUM working pressure of the water heater (150 psi). Install the valve into an opening provided and marked for this purpose in the water heater, and orient it or provide tubing so that any discharge from the valve will exit only within 150mm (6 in.) above, or at any distance below the structural floor and cannot contact any live electrical part. The discharge opening must not be blocked or reduced in size under any circumstances. The end of the relief pipe opening should terminate near a floor drain or other suitable location not subject to blocking or freezing. **DO NOT** thread, plug or cap the relief pipe opening.



WARNING

Failure to install a listed 3/4" Temperature & Pressure Relief Valve will release the Manufacturer from any claim that might result from excessive temperatures and pressures.

III) INSTALLATION

Plumbing

1. The cold water inlet is identified at the top of the heater (unless bottom entry). The hot water connection is also identified at the top of the heater. Install a shut-off valve in the cold line approximately 1m (3 ft.) from the inlet to the heater where it is in convenient reach. This valve is for emergency shut-off and **MUST** be kept open during the operation of the heater.
2. The water connection fittings contain a plastic lining to minimize corrosion and some models include plastic heat traps. Do not apply heat to these nipples when making solder connections. Sweat a piece of tubing to adapter before fitting adapter to nipple.
3. After installing the water piping, cover with the pipe insulation (if supplied with this heater). Use the insulation to cover 610mm (2 ft.) of hot and cold piping nearest to the heater.
4. A combination Temperature and Pressure relief valve **MUST** be installed. In some cases it is necessary that a Tee be fitted in the top of the heater that allows the temperature probe to reach into the top of the tank (see Figure 4). No shut-off valve of any kind is permitted between the tank and the relief valve. The relief valve discharge line must be piped to a drain or fixture, and must terminate a maximum of 300mm (12 in.) (Canada) or 150mm (6 in.) (U.S.A.) from the floor.

Electrical

1. Check to see that the element marking and nameplate data correspond with the electric service available. The junction box where electrical connections are made is located near the top of the heater, near the upper access door.
2. Install a circuit directly from the main fuse box. This circuit must be the right size for the length of run and the load (see Table 1).

MAX. WATTS	MAX. VOLTS		
	120 V	208 V	240 V
1500	20 A	10 A	10 A
3000	35 A	20 A	20 A
3500	40 A	20 A	20 A
4500		30 A	25 A
5500		35 A	35 A

NOTE: Water heater must be well grounded to the electrical supply service.

Table 1 Power Requirements

3. A ground wire must run from the green ground screw provided at the electrical connection point in the heater junction box to the ground connection at the service panel.
4. Adequate fusing must be provided at the service entrance as required by local codes and/or electric utility having jurisdiction. This can be accomplished with either a circuit breaker or fuse block in the service panel or a separate disconnect switch, so that electric power can be shut off easily when working on the heater.
5. Final connections are made at the junction box in the heater. Access to the junction box is obtained by removing the cover near the knockouts.
6. The heater you have received is internally wired. A specific wiring diagram is located inside the upper door or for certain models on the rating plate. All wiring is colour-coded and connections must be made as shown in the wiring diagram.

Wiring

TWO WIRE CIRCUIT FOR NON-SIMULTANEOUS OPERATION. SINGLE HIGH LIMIT.

The basic operation of a two-thermostat system (upper and lower) on an electric water heater of 240 volts is as follows: Only one element will come on at any one time. This is known as a flip/flop system. On a 240 volt water heater, there will always be 120 volts to both elements. The thermostat will direct the second leg of the 120 volts to the element to complete the 240 volts required for energizing the element.

Initial Start Up: When the tank is full of cold water, the upper thermostat will take priority and the top portion of the water will heat up to the setting of the thermostat. Once that temperature has been reached, the thermostat will then flip down the 120 volts to the lower thermostat. The thermostat switch closes and the bottom portion of the tank heats up until the water reaches the setting on that thermostat. At this

point the tank will be full of hot water.

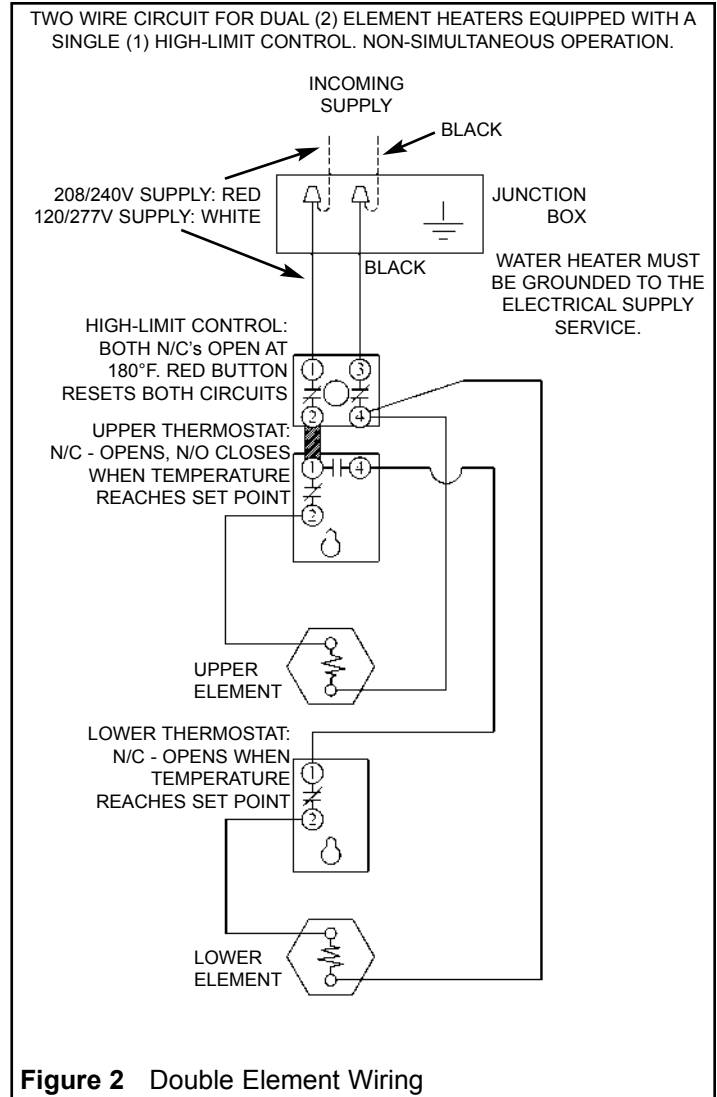
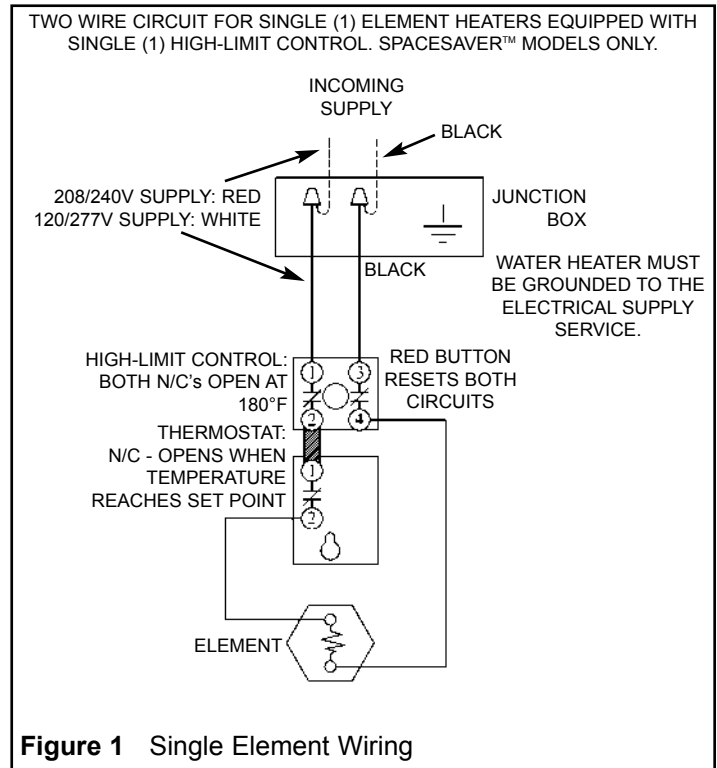

Normal Operation: When hot water is being used, cold water enters the bottom of the heater (either bottom feed or by diptube), and the bottom element will begin to heat the cold water. If lots of hot water has been used, the upper thermostat will take priority and the top portion of the heater will be heated. Once heated, the thermostat will flip down to the lower thermostat to heat the lower portion.

⚠ WARNING

Do not supply power to this water heater until you have verified that the unit is completely filled with water.

To ensure that the water heater is full of water and that all the air has been purged from the system, run all the hot water faucets in the house continuously for three (3) minutes.

Filling the Tank

NOTE: When filling, avoid water spillage. Do not allow the insulation of the heater to get wet as water can cause electrical malfunction.

1. Close the drain valve, and then open a hot water faucet.
2. Open the cold water supply valve.
3. When water runs out of the hot faucet, the tank is full.
4. Check the system for leaks.

Draining the Tank (completely)

If the power is to be turned off during the cold season and the tank is exposed to freezing temperatures, the water heater must be drained. Water will expand when it freezes and can damage the heater.

Completely drain as follows:

1. Make sure the electrical supply to the water heater is "OFF".
2. Turn off cold water supply.
3. Connect a garden hose to the end of the drain valve and direct this to a point lower than the heater.
4. Open a hot water faucet.
5. Open the drain valve on the heater - drain, keeping the drain valve open during the shutdown period.
6. To refill the heater, see "Filling the Tank" section.

Installation Check List

Check Here

- | | | |
|----|---|--------------------------|
| 1. | Are the fuse and wire sizes correct? | <input type="checkbox"/> |
| 2. | Is the certified relief valve installed? | <input type="checkbox"/> |
| 3. | Are you sure that in case of water leakage, the building, furniture, carpeting or other property will not be damaged? | <input type="checkbox"/> |
| 4. | Has the relief valve been piped to a suitable drain point? | <input type="checkbox"/> |
| 5. | Is the relief valve discharge unobstructed? | <input type="checkbox"/> |
| 6. | Is the heater completely filled with water? | <input type="checkbox"/> |
| 7. | Is the cold supply valve open? | <input type="checkbox"/> |

If the answers to the above are "Yes", turn on the power and enjoy all the hot water you need, all the time.

**⚠ WARNING:
Risk of scalding**

There is a hot water scald potential if the thermostat is set too high.

Adjusting the thermostat past the 49°C (120°F) bar on the temperature dial will increase the risk of scald injury. Hot water can cause severe burns in:

- 1 1/2 seconds at 66°C (150°F)
- 3 seconds at 60°C (140°F)
- 20 seconds at 54°C (130°F)

IV) OPERATION

Temperature Adjustment

Thermostats are factory set at 140°F (60°C) (Canada), 120°F (49°C) (U.S.A.). The thermostats operate automatically. They can be adjusted to provide warmer or cooler water temperature. Set both thermostats to the SAME setting (if applicable).

If water temperature adjustment is required:

1. Turn the electrical supply to the water heater "OFF".
2. Remove the access door(s) and insulation pad(s).
3. Check with a voltage tester at terminal 1 and 3 of the limit control that power is indeed "OFF".
4. Adjust the thermostat(s) to the water temperature desired (if a two-thermostat system exists, set both thermostats at the same temperature).
5. Ensure insulation pad is in the door cavity. Replace access door(s).
6. Turn the electrical supply to the water heater "ON".

Temperature Limit Control

For safety, a non-adjustable high limit temperature switch will shut off the power when excessive water temperatures are reached. This switch must be re-set manually. See "Trouble-Shooting" section.

V) MAINTENANCE

Temperature & Pressure Relief Valve

Manually operate the temperature and pressure relief valve at least once a year to make sure it is working properly and that there are no blockages. To prevent water damage, the valve must be properly connected to a discharge line that terminates at an adequate drain. **Standing clear of the outlet (discharged water may be hot)**, slowly lift and release the lever handle on the temperature and pressure relief valve (see Figure 3) to allow the valve to operate freely and return to its closed position. If the valve fails to completely reset and continues to release water, immediately turn "OFF" the electrical supply to the tank, and close the cold water supply valve and call a qualified service techni-

cian. In systems where the relief valve discharges periodically, this may be due to thermal expansion causing pressure build up. See "Pressure Build-Up (Thermal Expansion)" section.

CAUTION
The out-flowing water is hot. Avoid splashing the water on yourself or on the surroundings where it may cause damage.

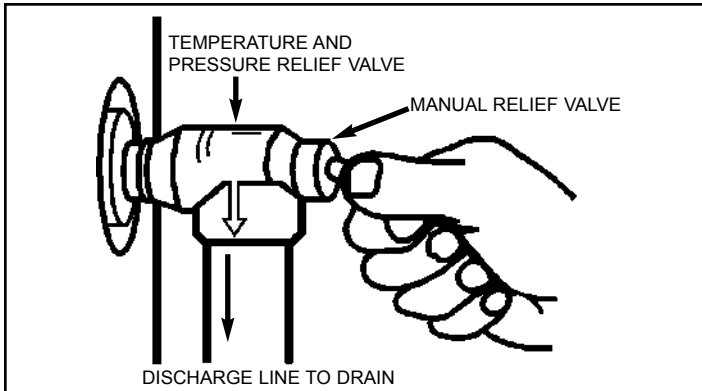

Figure 3 T&P Relief Valve Test

Element Replacement

WARNING
Electrical Shock Hazard

Disconnect power before servicing. Replace all parts and panels before operating. Failure to do so can result in death or electrical shock.

1. See "Draining the Tank" section to remove water from the heater.
2. Turn the electrical supply to the water heater "OFF".
3. Remove the access door(s) and insulation pad(s).
4. Disconnect wires from heating element terminals.
5. Unscrew the element using a 1-1/2 in. socket wrench or tool number S1008, available from your water heater distributor.
6. Replace element with new one, taking care that sealing gasket is in the groove of element flange.
7. Re-connect wiring, and replace Di-Electric shields.
8. Ensure insulation pad is in the door cavity. Replace access door(s).
9. Fill tank with water **BEFORE** turning **ELECTRICITY** on. See "Filling the Tank" section.

Thermostat Replacement

1. Turn the electrical supply to the water heater "OFF".
2. Remove the access door(s) and insulation pad(s).
3. Disconnect wires from thermostat(s).
4. Lift prongs off bracket and slide thermostat up and out.

5. Replace in reverse order, taking care that thermostat(s) is **flush against the tank**.
6. Ensure insulation pad is in the door cavity. Replace access door(s).
7. Turn the electrical supply to the water heater "ON".

Cathodic Protection: Anode Maintenance

Your water heater has been supplied with an anode rod that protects the tank from corrosion. As the rod works, it slowly dissolves over time and must be replaced. If the anode is less than 10mm (3/8 in.) diameter, or any exposed bare core, replace. Depending on water conditions, an anode can last from one to ten years. Many localities treat their water, which can have significant effect on the life of your heater. Water conditioning such as over softening can accelerate the rate at which the anode rod is consumed. Rapid depletion can leave a heater unprotected causing a premature failure. As with any water heater, it is good practice to check the anode annually to see if it needs replacing.

Anode Inspection/Change

1. Turn "OFF" the electrical supply to the tank.
2. Close the cold water supply valve.
3. Open a nearby hot water faucet served by the system to depressurize the system.
4. Connect a hose to the drain valve and drain enough water to empty the piping system as directed in the "Draining the Tank" section.
5. Using a 1-1/16 in. socket, remove the anode and inspect it. The surface may be rough, full of pits and crevices, but this is normal. If it is less than approximately 6mm (1/4 in.) in diameter, or the inner steel core is exposed, the anode should be replaced.
6. Apply Teflon™ tape or sealing compounds approved for use with potable water, to the threads of the anode and install into the tank top.
7. Open the cold water supply valve and open a nearby hot water faucet to purge air from the tank as directed in the "Filling the Tank" section.
8. Check for leaks, repair as required, and re-test.
9. Turn "ON" the electrical supply to the tank.

Operating a water heater without an actively working anode rod will void any warranties, stated or implied.

Tank Clean-Out

1. A clean-out opening is provided on certain models for periodic cleaning of the tank. Power supply must be shut off and the heater drained before opening the clean-out.
2. To clean heater through the clean-out opening, proceed as follows:
 - a) Remove outer door from side of the casing.
 - b) Mark the insulation at the 12 o'clock position. Using the opening in the outer casing as a guide cut out the insulation covering the clean-out flange.
 - c) Remove the six (6) hex head screws securing the tank clean-out plate and remove the plate.
 - d) Remove lime, scale or sediment using care not to damage the glass lining of the tank.

- e) Inspect the clean-out gasket. If it shows signs of wear, a new gasket is required.
- f) Install the clean-out plate. Be sure to draw plate up tight by tightening screws securely.
- g) Position the insulation so the mark is aligned, and replace the door.

Trouble-Shooting

Follow the preceding instructions carefully and your heater should provide long and trouble free service. If problems do arise however, the following will be of assistance:

Not Enough Or No Hot Water

1. Make sure the electrical supply to the water heater is "ON".
2. Check for loose or blown fuses and loose connections in the water heater circuit.
3. If the water was too hot and is now cold, the high limit temperature switch may have operated. To reset this, proceed as follows:
 - a) Turn the electrical supply to the water heater "OFF".
 - b) Remove the access door then turn back the insulation.
 - c) Reset the control by pushing in the red button marked 'RESET'.
 - d) Repack the insulation then replace access door.
 - e) Turn the electrical supply to the water heater "ON".
4. The capacity of the tank may have been exceeded by large demands of hot water. Wait at least one hour then check for hot water at normal hot water faucet.
5. The incoming cold water may be colder because it is winter. If so, it will take longer to heat the water.
6. If none of the above result in adequate hot water, call a qualified service technician.
7. If there is no HOT water, check the upper element.
8. If there is limited HOT water, check the lower element.
9. If water is LUKEWARM check for proper incoming voltage.

Water Leakage Is Suspected

1. Check all pipes and fittings for leaks, including the drain valve, element(s) and relief valve.
2. See if the apparent leakage might be condensation. In warm or humid locations, condensation can accumulate and run from the heater and piping.
3. If leakage is from the relief valve discharge pipe, it may represent a normal condition. Call a qualified service technician to check the valve carefully.
4. If you cannot identify or correct the source of leakage:
 - a) Turn off electrical supply to the heater.
 - b) Close the cold water inlet valve to the heater.
 - c) Open a hot water faucet.
 - d) Contact a qualified plumber or service technician.

Water Is Too Hot

Adjust the thermostats to a lower setting. See "Temperature Adjustment" section. It is imperative that the thermostat is flush against the tank. See "Thermostat Replacement" section.

Hot Water Odour

On occasion, and depending on your location, hot water may develop a strong odour. This can be especially problematic in regions where the water contains some sulphur, which results in hot water having a "rotten egg" smell. If this occurs, drain the system completely, flush thoroughly and refill. If the problem persists, the anode rod may need to be changed from magnesium to one made of aluminum. In certain cases chlorinating and flushing of the water heater may be required. Contact your dealer or water supplier.

Discoloured Water

- Water rich in iron or other minerals can produce red or brown staining. Heating water generally worsens this situation.
- Black water can be an indication of organic contaminants in the water supply. This can be problematic in areas where the water is obtained from surface or contaminated sources. Organic particles can develop bacterial growth, causing potential health hazards. Contact your water supplier for proper filtration or water conditioning equipment. For bacterial problems contact your local health authority. Also see "Hot Water Odour" section.
- A sudden appearance of rusty water can indicate the anode rod has been depleted. The remaining steel core wire may be corroding, releasing iron particles into the water. Inspect and replace as necessary. Also see "Cathodic Protection: Anode Maintenance" section.

Water Heater Makes Noise

Sediment, sand or scale can accumulate resulting in "rumbling" or a "hissing" noise. Water heaters need to be flushed regularly to minimize buildup. Severe accumulations can cause premature failure of the water heater elements.

Extended Non Use Service

CAUTION

Hydrogen gas can be produced in a hot water system served by this storage tank that has not been used for a long period of time (generally two (2) weeks or more). **Hydrogen gas is extremely flammable and can ignite when exposed to a spark or flame.** To reduce the risk of injury under these conditions, it is recommended that the hot water faucet be opened for several minutes at the kitchen sink before using any electrical appliance connected to the hot water system. Use caution in opening faucets. If hydrogen is present, there will probably be an unusual sound such as air escaping through the pipe as the water begins to flow. There should be no smoking or open flame near the faucet at the time it is open.

Pressure Build-Up (Thermal Expansion)

During the heating cycle of the water heater, the water expands creating a pressure build-up in the plumbing system. If the pressure exceeds 150 psi, water will come out of the valve. This is a normal safety function of the T&P valve. The water supply meter may have a check valve or back flow preventer inside. This can increase the possibility of

pressure build-up. Causes of discharge can be thermal expansion, excess system pressure, too high a temperature setting on the thermostat or something in the water heater causing excess temperatures in the heater.

Thermal Expansion

When water is heated it expands. For example, in a 40-gallon water heater, water being heated to its thermostat setting will end up expanding by approximately 1/2 gallon. This extra volume created by the expansion has to go somewhere or pressure will dramatically increase, such as when water is heated in a closed system. A good indication of thermal expansion is when the T&P valve releases about one cup of water for every 10 gallons of heater capacity with each heating cycle. The T&P valve is functioning properly when it relieves pressure caused by thermal expansion, but frequent relief can result in a build up of natural mineral deposits on the valve seat, rendering the valve inoperative. Should this happen, the T&P valve needs to be replaced. To prevent this 'T&P VALVE' from discharging hot water, the loss of energy and reduce the possible build-up of lime in the 'T&P VALVE' there are two (2) recommendations:

OPTION 1: Install a 125 psi Pressure Relief (only) valve in the cold water supply line. Make sure that the discharge of this valve is directed to a drain to prevent water damage and it is protected from freezing,

OR

OPTION 2: Install an expansion tank on the cold water supply line. For every 50 U.S. gallons of stored water, the expansion tank must have a minimum capacity of 1.5 U.S. gallons.

Temperature Relief

The T&P valve will discharge varying amounts of water, but typically more than you would experience from thermal expansion. Check the temperature in relation to the setting on the thermostat dial. A malfunctioning thermostat could cause the water to get too hot.

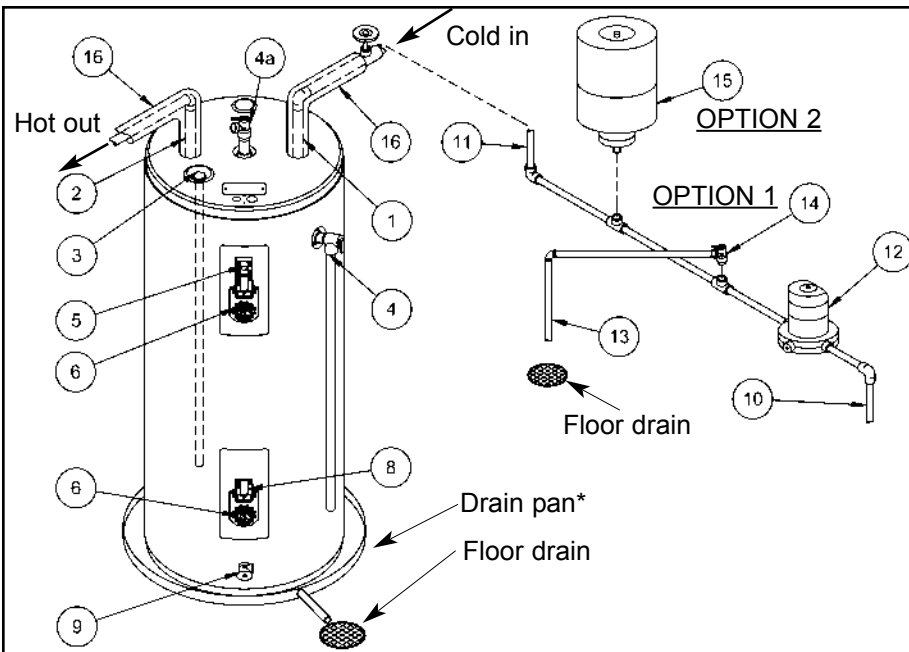

**SPACESAVER™ MODELS
(SIDE OUTLET) ONLY
NOTE TO INSTALLERS:**

A bent tube (as shown) is installed for the hot water outlet on side outlet water heaters to ensure a maximum of hot water supply. This fitting must be aligned properly. The 'line' on the fitting must be oriented pointing up. When in correct position, the hot water is drawn from the highest point in the tank.

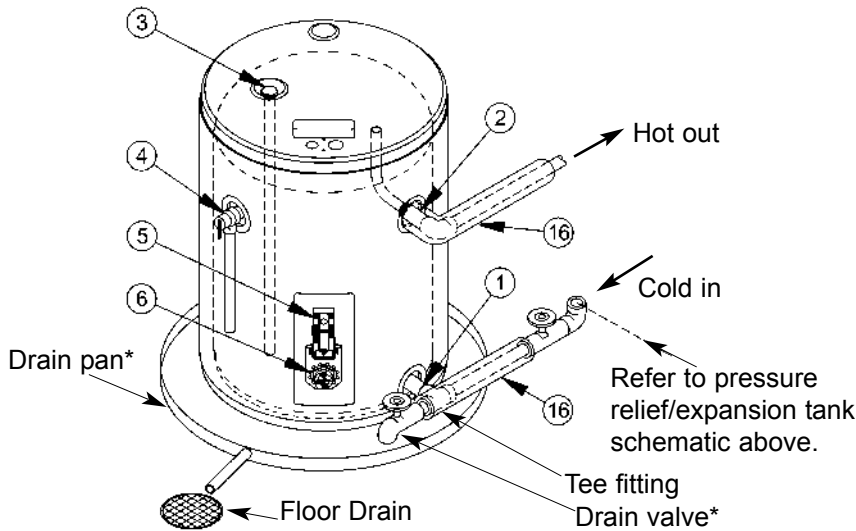
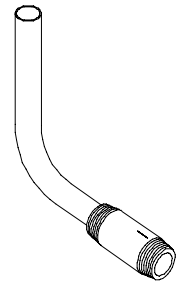

1. Cold water inlet
2. Hot water outlet
3. Anode(s)
4. Temperature and pressure (T&P) relief valve*
- 4a. Alternate location of T&P relief valve*
5. Thermostat with High-limit switch
6. Element
7. Access door - not illustrated
8. Thermostat
9. Drain valve
10. Water supply to meter
11. Water supply to water heater
12. Water meter with backflow preventer
13. Overflow
14. Pressure relief valve
15. Expansion tank
16. Pipe Insulation (mandatory if supplied with heater)

*Items to be supplied by installer.

Options 1 and 2 show the location of pressure relief and/or expansion tank if a check valve or pressure reducing valve is in the cold water supply to the house. Use option 1 or 2 as convenient. If a pressure relief valve is used (OPTION 1) select one with a setting 25 psi below the relief valve rating used on the heater.

Figure 4 Parts Reference

LIMITED WARRANTY

See Rating Label Serial Number prefix for Warranty Code. Reduced warranty period applies to Newfoundland.

Warranty Code:	P	R	S	T	U	V	W	Y
Standard Warranty Years:	3	5	6	7	8	9	10	12
Reduced Warranty Years:	3	3	3	5	5	5	5	7

RESIDENTIAL STORAGE TANK TYPE WATER HEATER FOR INSTALLATION IN A SINGLE FAMILY DWELLING

A. WHO IS COVERED.

GSW WATER HEATING AND ITS SUPPLIERS, (herein collectively referred to as "Manufacturer") warrants only to the original consumer purchaser (hereinafter "Owner") of the water heater, within the boundaries of continental United States, or Canada, or their territories, so long as he or she continuously occupies the single family dwelling in which this water heater is initially installed for the period specified below. This warranty is not transferable. This warranty is reduced to one year if the water heater is used in a commercial, or industrial application, or if the water heater is used to supply more than one dwelling unit. Consumers must retain point-of-sale proof of purchase to validate warranty entitlement.

B. WHEN IT IS COVERED.

The water heater is warranted only when it is installed, operated and maintained in accordance with the printed instructions accompanying the water heater. The water heater shall/must be installed in such a manner that, if the tank or any connection thereto should leak, the resulting flow of water will not cause damage to the area in which it is installed. The water heater's temperature and pressure relief valve must be piped to the nearest drain to avoid damage in the event the valve is actuated. For detailed instructions read the manual accompanying the water heater and review drawings in the manual.

C. WHAT THE MANUFACTURER WILL DO AND THE PERIOD OF COVERAGE.

- The Inner Tank.** If the inner tank leaks within the warranty period shown in the table at the top of this page after the original installation, Manufacturer will furnish a new water heater of Manufacturer's then prevailing comparable model. If industry standards, regulatory changes, product improvements or product obsolescence prohibits Manufacturer from furnishing an identical model replacement water heater under this warranty, the Owner will be furnished with a new water heater of comparable capacity; however, the Owner will be charged for the additional value of the item(s) which Manufacturer has incorporated in the replacement water heater. A prior authorization number must be obtained from the Manufacturer before replacing the water heater. This warranty is limited to one replacement water heater at the original installation site.
- Component Part.** If any component part other than the inner tank proves to Manufacturer's satisfaction to be defective in material or workmanship within one (1) year, the Manufacturer will furnish the Owner with a replacement for the defective part(s). This warranty is limited to one replacement component part for each original part.
- Return of Defective Water Heater and Component Parts.** Manufacturer reserves the right to examine the alleged defect in the water heater or component part(s), and it will be the Owner's obligation (See paragraph D.5) to return the water heater and/or component part(s) to the Manufacturer.
 - When returning a water heater it must include all component parts and the data plate label.
 - When returning component part(s), they must be individually tagged and identified with the water heater's product number, model number, serial number, date of purchase and date of installation.
 - THERE ARE NO WARRANTIES WHICH EXTEND BEYOND THE DESCRIPTION ON THE FACE HEREOF. THIS EXPRESS WARRANTY IS, WHERE PERMITTED BY LAW, IN LIEU OF AND EXCLUDES AND REPLACES ALL OTHER CONDITIONS, WARRANTIES, GUARANTEES, REPRESENTATIONS, OBLIGATIONS OR LIABILITIES OF THE MANUFACTURER OF ANY NATURE OR KIND, EXPRESS OR IMPLIED, HOWEVER ARISING (WHETHER BY CONTRACT, CONDUCT, STATEMENT, STATUTE, NEGLIGENCE, PRINCIPLES OF MANUFACTURER'S LIABILITY, OPERATION OF LAW OR OTHERWISE) WITH RESPECT TO THE UNIT OR ITS FITNESS FOR A PARTICULAR PURPOSE, MERCHANTABILITY, INSTALLATION, OPERATION, REPAIR OR REPLACEMENT. THE MANUFACTURER EXPRESSLY DISCLAIMS ANY AND ALL IMPLIED WARRANTIES. IN NO EVENT WILL THE MANUFACTURER'S LIABILITIES EXCEED THE COST OF THE DEFECTIVE PART(S) OR UNIT.

D. WHAT THIS WARRANTY DOES NOT COVER.

- The Unit must not be installed where water damage can result from a leak, while provision(s) shall be made for directing any water escaping from the Unit, to a properly operating drainpipe. As all units of this type may eventually leak, you must protect against any potential water damage. The Manufacturer accepts no responsibility for such damage, nor any incidental or consequential loss, nor damage(s) related thereto, suffered by the Owner of the Unit nor by any third party.
- Manufacturer shall not be liable under this warranty and this warranty shall be void and have no effect if the following events occur:
 - The water heater or any of its component parts have been subject to misuse, alteration, neglect or accident; or
 - The water heater has not been installed in accordance with the applicable local plumbing and/or building code(s) and/or regulations or in their absence, with the latest edition of the Natural Gas and Propane Installation Code, and/or the Canadian Electrical Code; or
 - The water heater is not installed, operated and maintained in accordance with the Manufacturer's instructions; or

- d. The water heater or any of its component parts are damaged or fails from operation with an empty or partially empty tank (such as, but not limited to elements burned out in a dry tank); or
 - e. The water heater or any part has been under water; or
 - f. The water heater is exposed to highly corrosive atmospheric conditions. No warranty extends, for example, and without limitation of the foregoing, to Units exposed to: salts, chemicals, exhausts, pollutants or contaminants; or
 - g. The water heater is not continuously supplied with potable water; or
 - h. The water heater replacement is requested for reasons of noise, taste, odor, discoloration and/or rust; or
 - i. The water heater is operated at temperatures exceeding the maximum setting of the thermostat and/or high limit control provided by the Manufacturer, or at water pressures exceeding the pressure reading stated on the Unit; or
 - j. The water heater is operated without an operating anode; or
 - k. The water heater is supplied or operated with deionized water; or
 - l. The water heater is removed from its original installation location; or
 - m. The water heater is installed outdoors (this water heater is intended only for indoor installation); or
 - n. The water heater is converted, or is attempted to be converted, from one voltage or wattage to another, if an electric water heater, or from one type gas to another, if a gas water heater; or
 - o. The water heater has not been fired at the factory rated input and fuel for which it was factory built; or
 - p. The water heater or any of its component parts fail due to sediment build-up; or
 - q. The water heater does not have installed a properly operating temperature and pressure relief valve, certified to ANSI Z21.22/CSA "Requirements for Relief Valves for Hot Water Supply Systems"; or
 - r. The water heater or any of its component parts fail because of fire, floods, lightening, or any other act of God, or any other contingency beyond the control of the Manufacturer; or
 - s. The water heater is installed in a closed system without adequate provision for thermal expansion.
3. Except when specifically prohibited by the applicable law, the Owner, and not the Manufacturer, shall be liable for and shall pay for all charges for labour or other expenses incurred in the removal, repair or replacement of the water heater or any component part(s) claimed to be defective or any expense incurred to remedy any defect in the product. Such charges may include, but are not necessarily limited to:
- a. All freight, shipping, handling and delivery costs of forwarding a new water heater or replacement part(s) to the Owner.
 - b. All costs necessary or incidental in removing the defective water heater or component part(s) and installing a new water heater or component part(s).
 - c. Any material required to complete, and/or permits required for, installation of a new water heater or replacement part(s), and
 - d. All costs necessary or incidental in returning the defective water heater or component part(s) to a location designated by the Manufacturer.
4. The terms of this Limited Warranty cannot be modified by any person, whether or not he/she claims to represent or act on behalf of the Manufacturer.
- E. HOW THE ORIGINAL OWNER CAN MAKE A WARRANTY CLAIM.
- 1. The Owner should submit the warranty claim directly to Manufacturer's Service Department, at the address or phone number listed below, and Manufacturer will arrange for the handling of the claim.
 - 2. Whenever any inquiry or request is made, be sure to include the water heater's catalogue number, model number, serial number, date of purchase, date of installation, and location of installation.

This warranty and the Manufacturer's obligations shall be construed and determined in accordance with the laws of both the Province of Ontario, and of Canada in force therein. This Warranty does not affect specific legal rights of a consumer under applicable law, except to the extent that such rights may be waived or replaced, and the provisions hereof are deemed to be amended to the extent necessary. The unenforceability of any provision, in whole or in part, of this Certificate shall not affect the remaining provisions. Any and all repair and/or replacement of part(s) or Unit are the sole and exclusive remedy available against the Manufacturer.

GSW Water Heating
 599 Hill Street West
 Fergus, ON Canada N1M 2X1
 Should you have any questions please
 Email us at techsupport@gsw-wh.com or
 Visit our websites: www.gsw-wh.com or
www.johnwoodwaterheaters.com or
 Call our Technical Support line at
 1-888-GSW-TECH (479-8324)