

Quiet, reliable and efficient operation in a quality design: the John Wood® Direct Vent water heater. The balanced flue design with a side wall vent termination allows installation in locations without a chimney. The sealed combustion chamber and co-axial vent uses fresh air taken from outside rather than pre-heated air from within the home. Ideal for applications where space is at a premium.

## Features

### Designed for Performance

- Thermopile design provides robust pilot to withstand down drafts and environmental conditions
- LED indicator:
  - Gives visual confirmation that pilot is on by flashing continuously
  - Provides diagnostics and troubleshooting
- Easy temperature adjustments
- Direct vent design means no external power supply or chimney required for operation/installation
- 90" Coaxial vent supplied with water heater
- Top mounted heavy duty anode rod for added tank protection
- Glass-lined tank for longer life
- Factory-installed plastic-lined nipples with heat traps
- Automatic gas control
- CFC-free foam insulation
- 50 gallon high input model available for combo applications
- Suitable for closet installations

### Safety Features

- Sealed combustion chamber design, eliminating the need for Flammable Vapour sensor

### Serviceability

- Combustion chamber is easy to access
- Conveniently located T&P and drain valve for ease of installation and serviceability

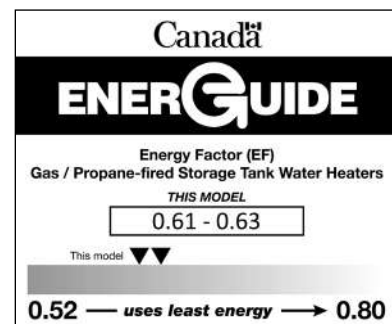

## WARRANTY

8 Year Limited Tank Warranty

6 Year Limited Parts Warranty

Consult installation manual for terms and conditions or visit [www.johnwoodwaterheaters.com](http://www.johnwoodwaterheaters.com) for more information.

### PERFORMANCE

Model	Capacity	Input	Maximum Certified Altitude	Recovery Rate at 90° F Temperature Rise	First Hour Rating	Energy Factor	BC Compliant
	USG(L)	BTU/h	FT (M)	GPH(LPH)	GPH(LPH)		
JW840S38N-DV	40 (151)	38,000	7,700 (2,347)	41 (154)	72 (273)	0.63	✓
JW850T40N-DV	50 (189)	40,000	7,700 (2,347)	43 (162)	91 (344)	0.62	✓
JW850T47N-DV*	50 (189)	47,000	7,700 (2,347)	50 (189)	92 (348)	0.61	✓

For Propane models sub N with P.  
\*Model has side connections.

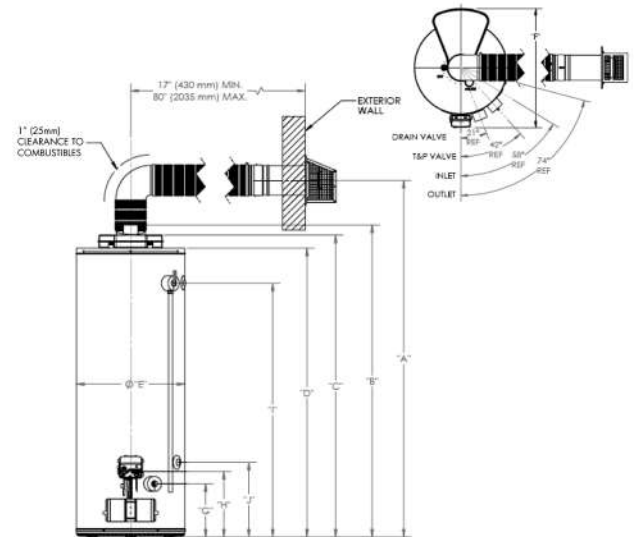

### DIMENSIONS & SHIPPING WEIGHT

Model	Height to Center of Vent	Height to Top of Flue Outlet	Height to Top of Air Box	Height to Top of Heater	Diameter	Overall Depth	Height to Drain	Height to Gas Inlet	Height to T&P	Height to Side Tap (Hot Out)	Height to Side Tap (Cold In)	Shipping Weight
	A IN (CM)	B IN (CM)	C IN (CM)	D IN (CM)								
JW840S38N-DV	64 (163)	54 3/8 (138)	52 1/2 (134)	49 5/8 (126)	22 (56)	29 (74)	10 3/4 (28)	13 1/4 (34)	42 3/8 (108)	N/A	N/A	178 (81)
JW850T40N-DV	73 (186)	63 5/8 (162)	61 3/4 (157)	58 7/8 (150)	22 (56)	29 (74)	10 3/4 (28)	13 1/4 (34)	51 5/8 (131)	N/A	N/A	200 (91)
JW850T47N-DV*	74 (188)	64 3/8 (164)	62 7/8 (160)	60 (153)	22 (56)	29 (74)	10 3/4 (28)	13 1/4 (34)	52 3/4 (134)	52 3/4 (134)	15 1/4 (39)	215 (98)

### PREFERRED INSTALLATION

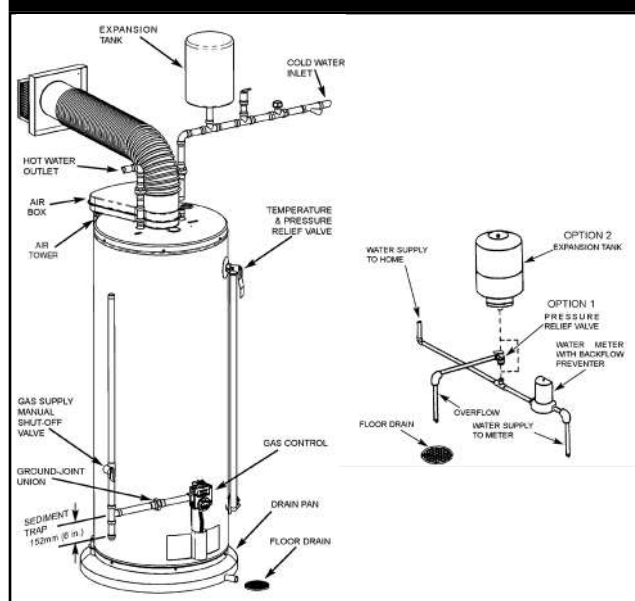

### VENT LENGTHS

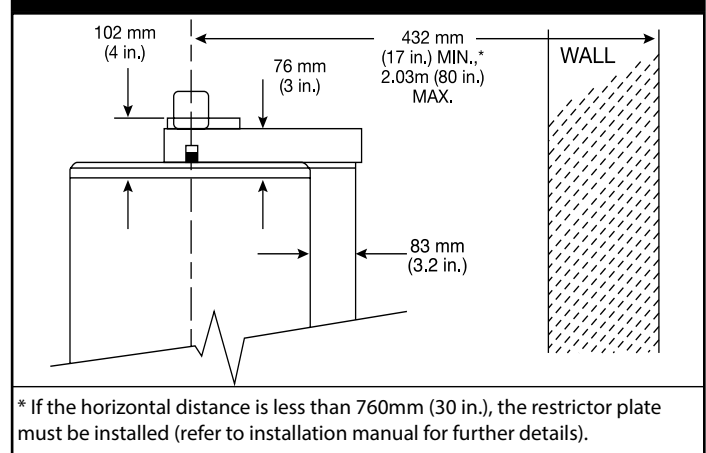

Refer to the installation manual for complete installation and venting requirements.