

John Wood<sup>®</sup> ENERGY STAR<sup>®</sup> qualified Atmospheric Vent gas water heaters comply with the latest ENERGY STAR<sup>®</sup> qualifications. With an installed flue damper, higher efficiencies can be achieved, therefore lowering operating costs and energy consumption.

## Features

### *Energy Savings*

- ENERGY STAR<sup>®</sup> qualified
- Meet and exceed NRCAN energy efficiency standards

### *Designed for Performance*

- Compact design – ideal as a replacement water heater
- Flue damper for increased energy efficiency and performance (Note: electric outlet required for operation)
- Includes a 20 foot 24-Volt power cord that can be increased up to 50 feet
- 24 Volt Gas Valve offers:
  - Diagnostic capabilities
  - Monitoring of damper to ensure proper operation and safety
  - Spark ignition eliminating the need for a standing pilot
- Robust 1/4" pilot tubing

### *Serviceability*

- Combustion chamber is easy to access
- Conveniently located T&P and drain valve for ease of installation and serviceability
- Dependable three-leg design for better leveling
- Top mounted heavy duty anode rod for added tank protection



## WARRANTY

8 Year Limited Tank Warranty

6 Year Limited Parts Warranty

Consult installation manual for terms and conditions or visit [www.johnwoodwaterheaters.com](http://www.johnwoodwaterheaters.com) for more information.

### PERFORMANCE

Model	Capacity	Maximum Certified Altitude	Input	Recovery Rate at 100°F/55°C Temp. Rise	First Hour Rating	Energy Factor
	USG (L)	ft (m)	BTU/hr	USG (L)	USG (L)	
<b>NATURAL GAS</b>						
JW840S38ES2	40 (151)	4,500 (1,372)	38,000	34.5 (131)	70 (265)	0.67
JW640T40ES2	40 (151)	4,500 (1,372)	40,000	36 (137)	75 (284)	0.67
JW850S40ES2	50 (189)	4,500 (1,372)	40,000	36 (137)	90 (341)	0.68
JW650T40ES2	50 (189)	4,500 (1,372)	40,000	36 (137)	90 (341)	0.68

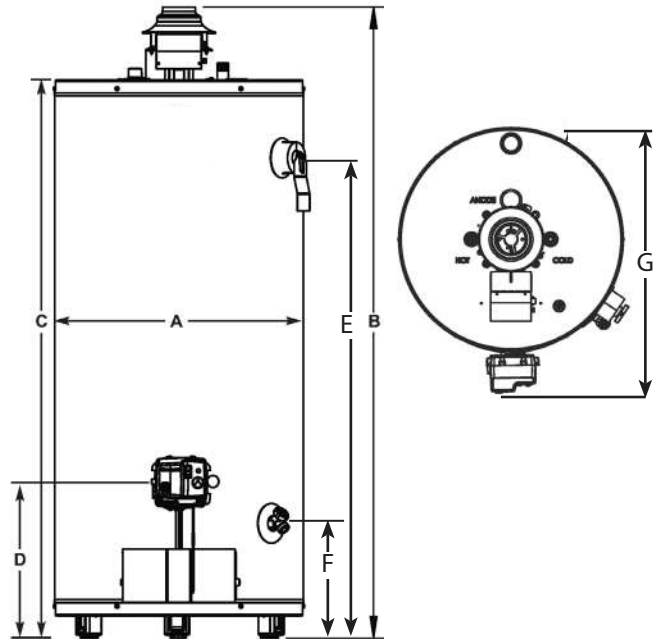

### DIMENSIONS & SHIPPING WEIGHT

Model	Tank Diameter	Installation Height	Height to Top of Tank	Height to Gas Inlet	Height to T&P	Height to Drain Valve	Overall Depth	Draft Hood Connector Diameter	Approximate Shipping Weight
	A in (cm)	B in (cm)	C in (cm)	D in (cm)	E in (cm)	F in (cm)	G in (cm)		in
<b>NATURAL GAS</b>									
JW840S38ES2	21 (53)	55 ¾ (142)	49 (125)	12 ½ (32)	42 ½ (108)	9 ½ (24)	23 ½ (60)	3 - 4	141 (64)
JW640T40ES2	19 (48)	66 (168)	59 ½ (151)	13 ½ (34)	53 ½ (136)	10 (25)	23 (58)	3 - 4	135 (61)
JW850S40ES2	22 ½ (57)	57 ¼ (145)	50 ½ (128)	12 ¾ (33)	44 (112)	11 (28)	25 (64)	3 - 4	176 (80)
JW650T40ES2	21 (53)	64 ¾ (165)	58 (148)	12 ¼ (31)	52 (132)	12 (31)	26 ½ (67)	3 - 4	168 (76)

### PREFERRED INSTALLATION

