

The John Wood[®] ENERGY STAR[®] qualified Power Direct Vent water heater is designed with a sealed combustion chamber, ultra-quiet blower and state-of-the-art gas control for highly accurate and reliable temperature regulation. Perfect for both residential new home construction and replacement water heater applications.

Features

Energy Savings

- ENERGY STAR qualified
- Exceeds NRCAN energy efficiency standards

Designed for Performance

- Compact design – ideal as a replacement water heater and for closet installations
- Exclusive TankSaver[®] design to prolong tank life
- Ultra-quiet blower
- Convenient 3/4" side water connections for combination applications on high input 65,000 BTU units (plugs are factory installed)
- Can be installed at altitudes up to 7,700 ft. (2,347 m)
- Factory installed T&P valve and drip tube
- Glass coated tank provides superior protection against corrosion

Safety Features

- Sealed Combustion Chamber design, eliminating the need for FV sensor
- Zero clearance to combustibles

Serviceability

- State-of-the-art gas control features advanced self-diagnostic capability that makes troubleshooting easy
- Conveniently located T&P and drain valve for ease of serviceability
- Auto-reset temperature switch monitors vent temperature

The Ultimate in Venting Flexibility

- Can be vented with ULC s636 PVC or CPVC or polypropylene up to 50 equivalent feet with 2" pipe, horizontally through the wall or vertically through the roof, except for 65,000 BTU high input model (see installation manual for full details)
- Can be installed using Concentric Vent Kit (see reverse or installation manual for full details)

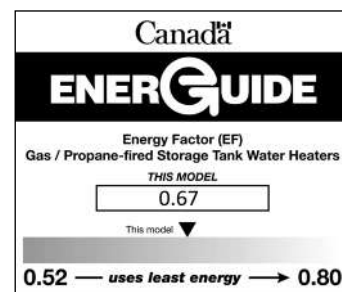

WARRANTY

8 Year Limited Tank Warranty

6 Year Limited Parts Warranty

Consult installation manual for terms and conditions or visit www.johnwoodwaterheaters.com for more information.



PERFORMANCE

Model	Capacity	Maximum Certified Altitude	Input	Recovery Rate at 90°F Temperature Rise	First Hour Rating	Energy Factor	BC Compliant
	USG (L)	FT (M)	BTU/h	GPH (LPH)	USG (L)		
NATURAL GAS							
JW4040SN-PDV-ES2	40 (151)	7,700 (2,347)	40,000	43 (163)	72 (273)	0.67	✓
JW5040SN-PDV-ES2	50 (189)	7,700 (2,347)	40,000	44 (167)	87 (329)	0.67	✓
JW85065SN-PDV-ES2*	50 (189)	7,700 (2,347)	65,000	72 (273)	114 (432)	0.67	✓

For propane models sub N for P

* Model has side water connections, only available for NG

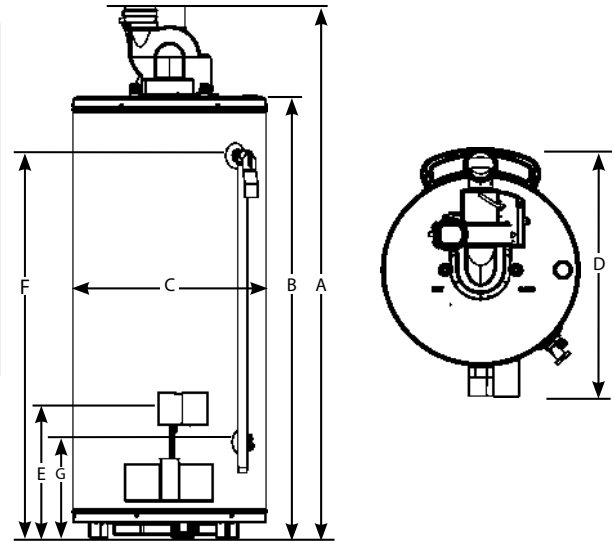

DIMENSIONS & SHIPPING WEIGHT

Model	Installation Height	Height to Top of Tank	Tank Diameter	Overall Depth	Height to Gas Inlet	Height to T&P	Height to Drain Valve	Height to Side Water Connections (not shown on drawing)		Vent Diameter	Shipping Weight
	A IN (CM)	B IN (CM)	C IN (CM)	D IN (CM)	E IN (CM)	F IN (CM)	G IN (CM)	Lower IN (CM)	Upper IN (CM)	IN	LBS (KG)
NATURAL GAS											
JW4040SN-PDV-ES2	59 ½ (151)	51 (130)	22 ½ (57)	25 ¾ (64.5)	15 (38)	43 ½ (111)	10 ¾ (27)	N/A	N/A	2-3	162 (73)
JW5040SN-PDV-ES2	68 ½ (174)	60 (152)	22 ½ (57)	25 ¾ (64.5)	15 (38)	52 ½ (134)	10 ¾ (27)	N/A	N/A	2-3	182 (82)
JW85065SN-PDV-ES2	69 ¾ (177)	61 ¼ (156)	22 ½ (57)	25 ¾ (64.5)	15 (38)	53 (135)	10 ¾ (27)	16 (41)	53 (135)	3	209 (95)

PREFERRED INSTALLATION

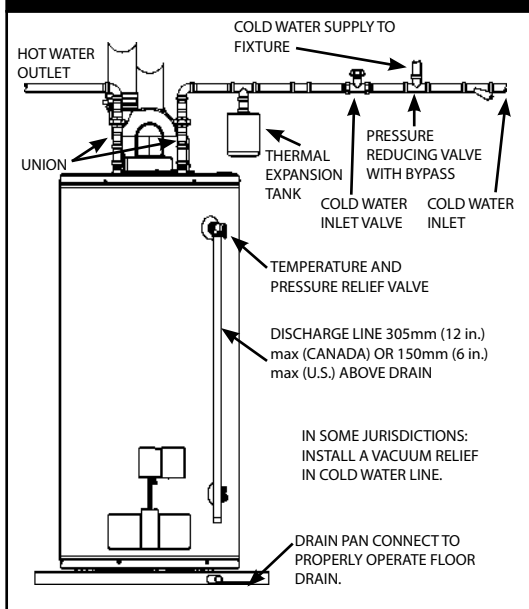

VENT PIPE LENGTHS

Model	Vent Pipe Diameter IN	Minimum Number of Elbows Required*	Minimum Vent Length with One Elbow FT (M)		Maximum Equivalent Vent Length FT (M)	
			Concentric	2 Pipe	Concentric	2 Pipe
JW4040SN-PDV-ES2, G4040SP-PDV-ES2	2	1	7 (2.1)	7 (2.1)	50 (15.2)	50 (15.2)
	3	1	7 (2.1)	7 (2.1)	100 (30.5)	100 (30.5)
JW5040SN-PDV-ES2, G5040SP-PDV-ES2	2	1	7 (2.1)	7 (2.1)	50 (15.2)	50 (15.2)
	3	1	7 (2.1)	7 (2.1)	100 (30.5)	100 (30.5)
JW85065SN-PDV-ES2*	3	1	7 (2.1)	7 (2.1)	30 (9.1)	50 (15.2)

* Refer to installation manual for further details.

CONCENTRIC VENT KITS

Description	Part Number
2" Concentric Vent Kit (POL KGAVT0701)	6911088
3" Concentric Vent Kit (POL KGAVT0801)	6911089