

ProLine® Direct Vent

Features

Designed for Performance

- ProLine® models are residential water heaters with commercial-grade quality
- Thermopile design provides robust pilot to withstand down drafts and environmental conditions
- Easy temperature adjustments
- 90" coaxial vent supplied with water heater
- Glass lining provides superior protection against tank corrosion
- Factory-installed plastic-lined nipples with heat traps
- Automatic gas control
- CFC-free foam insulation
- 50 USG high input model available for combination applications
- Suitable for closet installations
- 3/4" side taps available on 50 USG high input model for combination applications

Safety Features

- Sealed combustion system, eliminates the need for a Flammable Vapour sensor

Serviceability

- Easy-to-access combustion chamber
- Conveniently located T&P and drain valve for ease of installation and serviceability
- LED indicator:
 - Gives visual confirmation that pilot is on by flashing continuously
 - Provides diagnostics and troubleshooting
- Piezoelectric ignitor allows for push-button pilot lighting
- Top mounted heavy duty anode rod for added tank protection

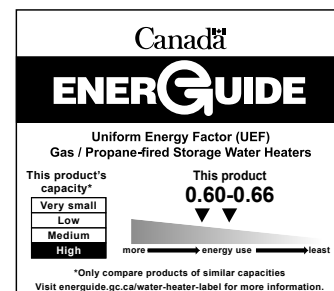

WARRANTY

6 year limited tank and parts
2 or 4 year tank warranty extension kits are available

PERFORMANCE

Model	Series	Capacity	Input	Maximum Certified Altitude	Recovery Rate at 90° F Temperature Rise	First Hour Rating	UEF	Warranty Tank/Parts
		USG (L)	BTU/h	FT (M)	GPH (LPH)	USG (L)		Years
DV40N	300/301	40 (151)	38,000	7,700 (2,347)	42 (159)	72 (273)	0.60	6/6
DV50N	300/301	50 (189)	40,000	7,700 (2,347)	43 (163)	91 (344)	0.66	6/6
DV50HIN*	300/301	50 (189)	47,000	7,700 (2,347)	51 (193)	92 (348)	0.65	6/6

For propane models sub N with P. Natural gas models are series 300. Propane models are series 301. All models comply with national energy efficiency regulations.
*Model has side connections.

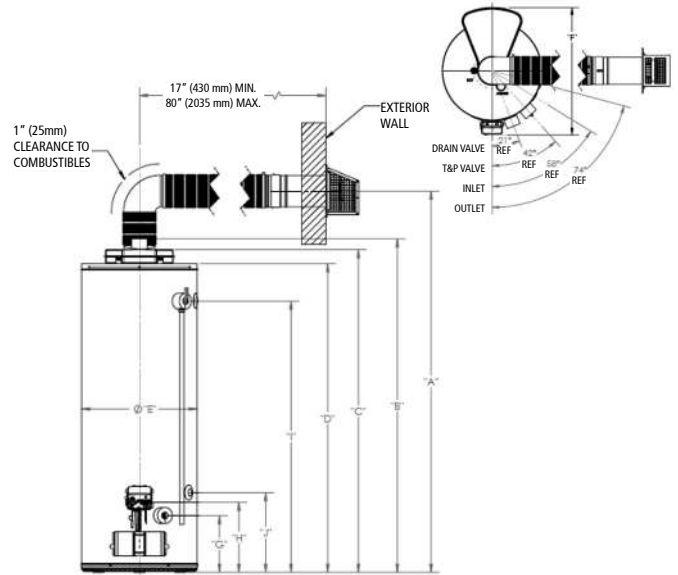

DIMENSIONS & SHIPPING WEIGHT

Model	Height to Center of Vent	Height to Top of Flue Outlet	Height to Top of Air Box	Height to Top of Heater	Diameter	Overall Depth	Height to Drain	Height to Gas Inlet	Height to T&P	Height to Side Tap (Hot Out)	Height to Side Tap (Cold In)	Shipping Weight
	A IN (CM)	B IN (CM)	C IN (CM)	D IN (CM)	E IN (CM)	F IN (CM)	G IN (CM)	H IN (CM)	I IN (CM)	I IN (CM)	J IN (CM)	LB (KG)
DV40N	64 (163)	54 3/8 (138)	52 1/2 (133)	49 3/8 (126)	22 (56)	29 (74)	10 3/4 (27)	13 1/4 (34)	42 3/8 (108)	N/A	N/A	178 (81)
DV50N	73 (185)	63 3/8 (162)	61 3/4 (157)	58 7/8 (150)	22 (56)	29 (74)	10 3/4 (27)	13 1/4 (34)	51 3/8 (131)	N/A	N/A	200 (91)
DV50HIM*	74 (188)	64 3/8 (164)	62 7/8 (160)	60 (152)	22 (56)	29 (74)	10 3/4 (27)	13 1/4 (34)	52 3/8 (134)	52 3/8 (134)	15 1/4 (39)	215 (98)

PREFERRED INSTALLATION

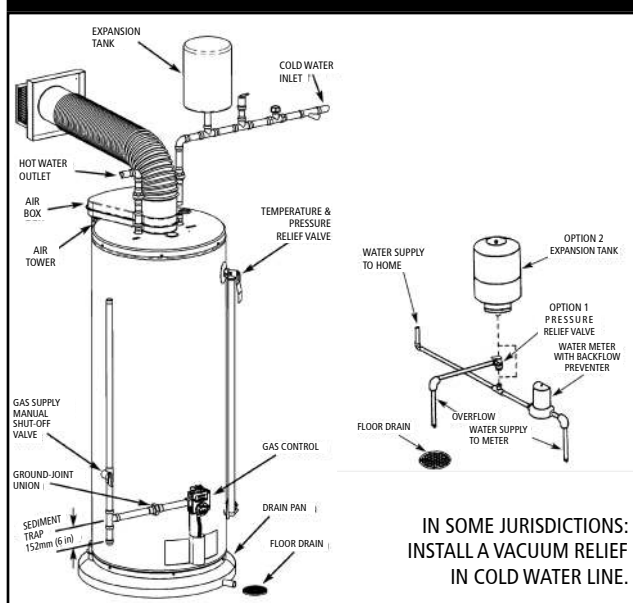

VENT LENGTHS

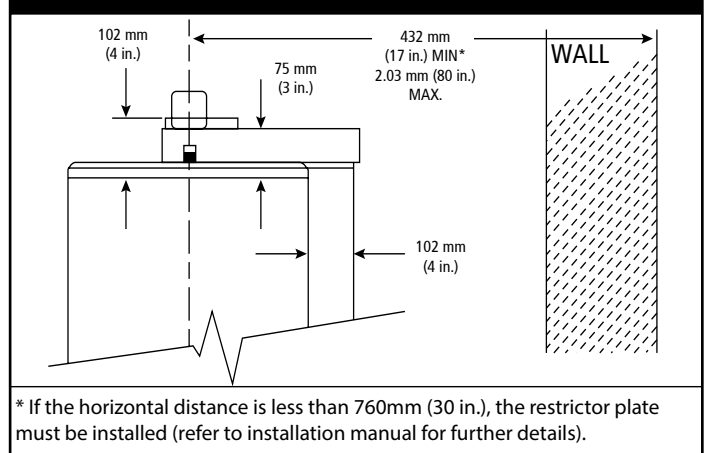

Refer to the installation manual for complete installation and venting requirements.